

# 999046361

Eco-Ball & Self cleaning  
drain pump system  
LBCF 33A-40A-47A  
12/01/2010

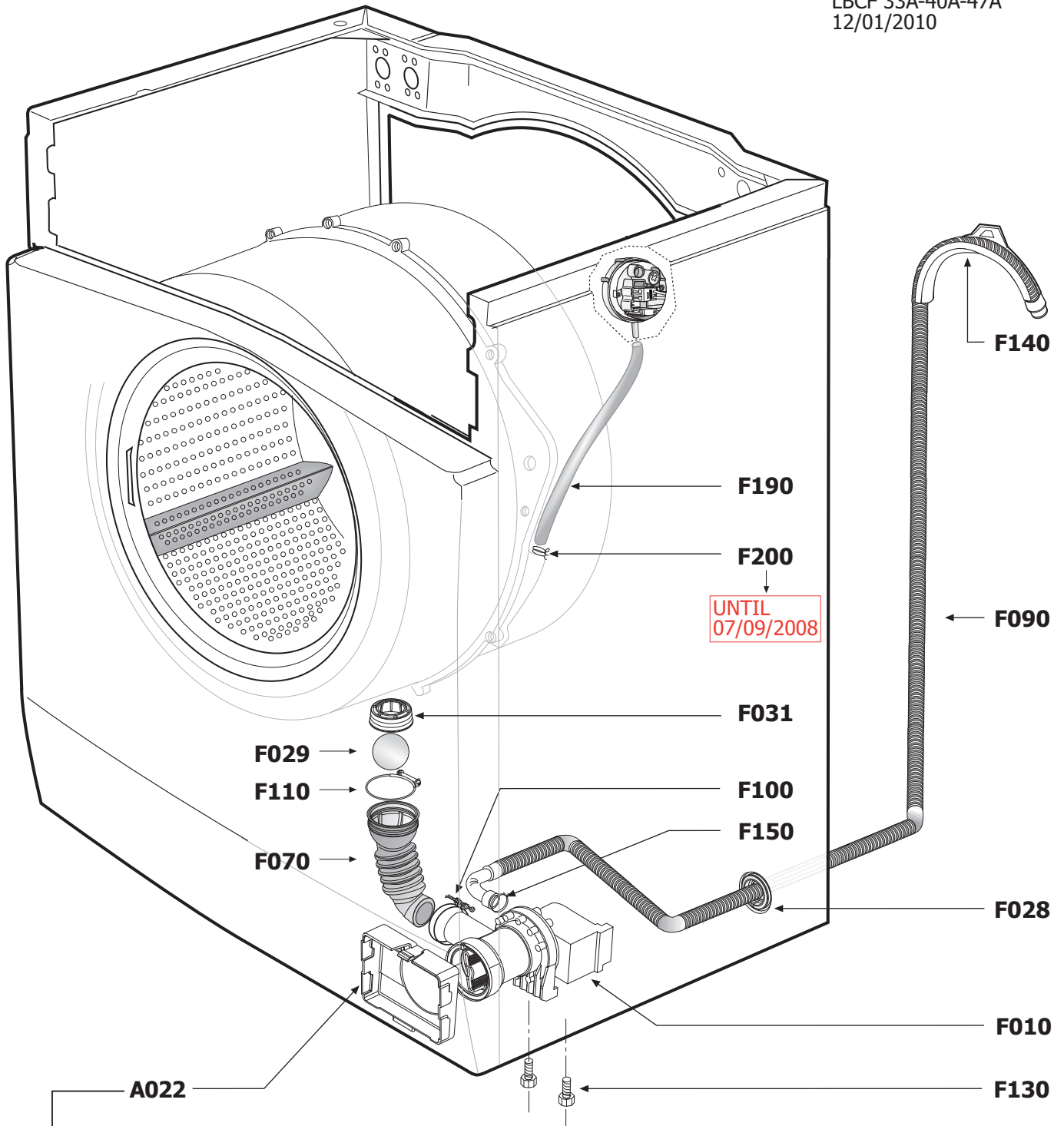

- I** → Protezione Pompa utilizzata esclusivamente su macchine provviste di Pannello frontale "T".
- F** → Protection Pompe de vidange utilisée exclusivement dans les machines ayant le Panneau frontal "T".
- GB** → Pump Cover used exclusively on machines fitted with "T" type cabinet front Panel.
- D** → Pumpenschutz ausschließlich an Maschinen mit Frontpaneel "T".
- E** → Protección Bomba utilizada exclusivamente en máquinas dotadas de Panel frontal "T".