

DAEWOO
ELECTRONICS



Service Manual

No-Frost

Combi-Refrigerator

Models:

ERF-366N, 366A

ERF-396N, 396A

ERF-416N, 416A

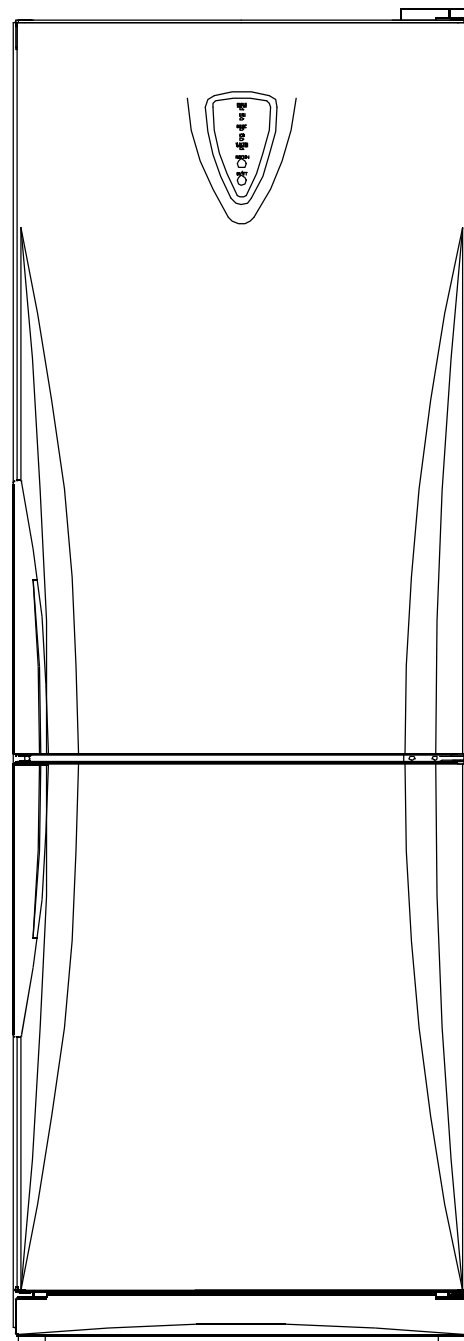

DAEWOO ELECTRONICS
MANUFACTURING ESPAÑA, S.A.

. CONTENTS

- 1. SPECIFICATIONS**
- 2. EXTERNAL DRAWINGS**
- 3. REAL VIEW**
- 4. MACHINE ROOM VIEW**
- 5. REFRIGERANT CYCLE**
- 6. TEMPERATURES DIAGRAM**
- 7. WIRING DIAGRAMS**
- 8. PCB CIRCUIT DIAGRAMS**
- 9. COMPONENTS DISASSEMBLY PICTURES**
- 10. DOOR POSITION CHANGE PROCESS**
- 11. EXPLODE DRAWING**
- 12. PARTS LIST**
- 13. PCB CONTROL FUNCTION**

1. SPECIFICATIONS

Model name		366N	366A	396N	396A	416N	416A
Division		Semi A	Full A	Semi A	Full A	Semi A	Full A
Refrigerant type		R-134A					
Refrigerant Q'ty		100 grs					
Blowing agent		C-PENTANE					
Cooling system		Fan cooling system					
Defrost system		Automatic start & Automatic stop system					
Compressor		Sanyo CBE-140L5Z					
Rated voltage		AC220~240V / 50Hz					
Rated input (A)		0.42A					
Lamp rated input (W)		15					
Gross capacity (liter)	Freezer	94	94	94	94	109	109
	Refrigerator	218	218	252	252	252	252
	Total	312	312	346	346	361	361
External dimension (mm)	Height	1765	1765	1896	1896	1985	1985
	Width	600	600	600	600	600	600
	Depth *	642	642	642	642	642	642
Energy class		A					
Freezing capacity(kg/24h)		5					
Star rating		* ***	* ***	* ***	* ***	* ***	* ***
Climate class		N	N	N	N	N	N
Net weight (kg)		70	70	74	74	76	76

REMARKS:

* Depth exception handle

* Division: Semi A = Semi automatic

Full A = Full automatic

1.2. Types of the approved safety standars



2. EXTERNAL DRAWINGS

2.1. ERF-366A, 396A, 416A

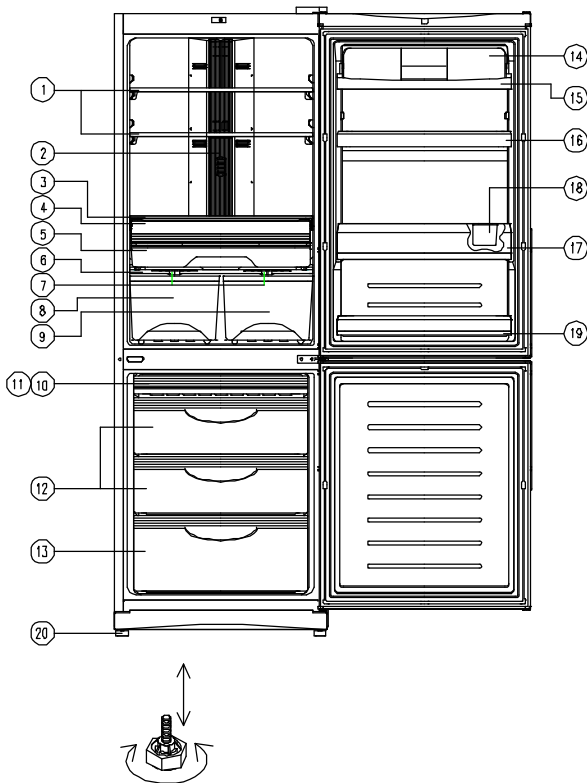

1. Shelves (ERF-366 A : 2EA)
(ERF-396 A : 3EA)
(ERF-416 A : 3EA)
2. Multi duct
3. Shelf of low temp compartment
4. Door of low temp compartment
5. Low temp compartment
6. Cover vegetable
7. Knob humidity
8. Vegetable case "L"
9. Vegetable case "R"
10. Case f "D"
11. Case icing (In "case f d")
12. Case f "B" (2EA)
Case f "C" (ERF-416 A : 2EA)
13. Case f "A"
14. Cover dairy
15. Dairy pocket
16. Pocket "R"
17. Bottle pocket
18. Guide bottle pocket
19. Multi pocket
20. Adjustable foot

1. Shelves (ERF-366 N : 2EA)
(ERF-396 N : 3EA)
(ERF-416 N : 3EA)

2. Knob control
3. Multi duct
4. Shelf of low temp compartment
5. Low temp compartment
6. Door of low temp compartment
7. Cover vegetable
8. Knob humidity
9. Vegetable case "L"
10. Vegetable case "R"
11. Case f "D"
12. Case icing (In "case f d")
13. Case f "B" (2EA)
Case f "C" (ERF-416 N : 2EA)
14. Case f "A"
15. Cover dairy
16. Dairy pocket
17. Pocket "R"
18. Bottle pocket
19. Guide bottle pocket
20. Multi pocket
21. Adjustable foot

2.2. ERF-366N, 396N, 416N

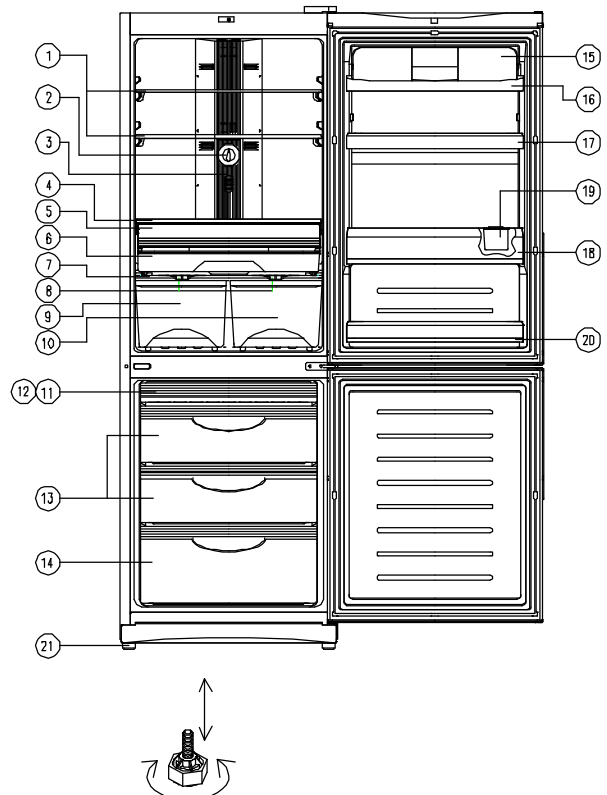

3. REAL VIEW



4. MACHINE ROOM VIEW

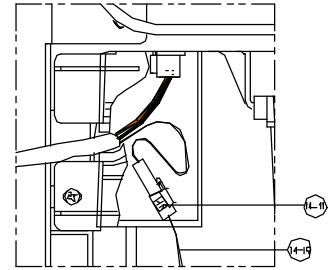

DETAIL 3X

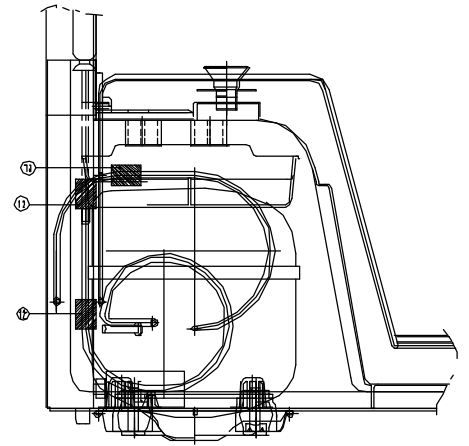
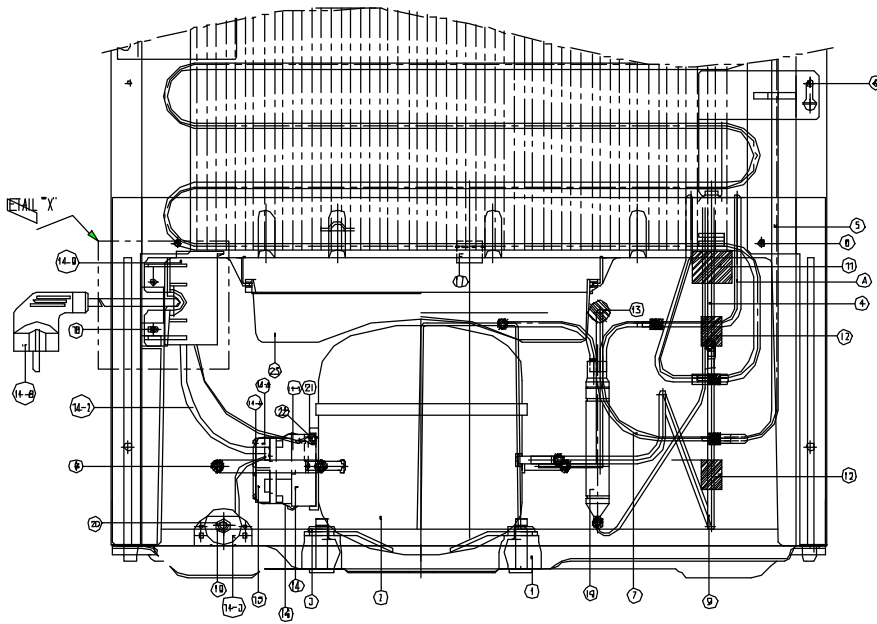

No.	PART NAME	No.	PART NAME	No.	PART NAME
A	PIPE HOT	14	BOX RELAY AS	17	CAP DRAINER
1	ABSORBER COMP	14-1	BOX RELAY	18	SCREW TAPPING
2	COMPRESSOR	14-2	HARNESS RELAY	19	SPECIAL WASHER R/C
3	FIXTURE COMP	14-3	CAPACITQR RUN AS	20	SPECIAL NUT R/C
4	EVAPORATOR AS	14-4	CABLE CLAMP	21	SPECIAL WASHER
5	PIPE WI-CONN AS	14-5	SCREW TAPPING	22	SCREW MACHINE
6	SPECIAL SCREW E	14-6	SWITCH P RELAY PTC	23	CASE VAPORI
7	PIPE CONN B	14-7	SWITCH P RELAY OL		
8	PIPE CHARGE	14-8	CODE POWER AS		
9	PIPE SUC. CONN	14-9	COVER ME HOUSING		
10	DRYER AS	14-10	HARNESS EARTH		
11	ABSORBER PIPE B (GUM)	14-11	LABEL EARTH		
12	ABSORBER PIPE C	15	RELAY COVER		
13	ABSORBER PIPE C	16	BAND RELAY		

5. REFRIGERANT CYCLE

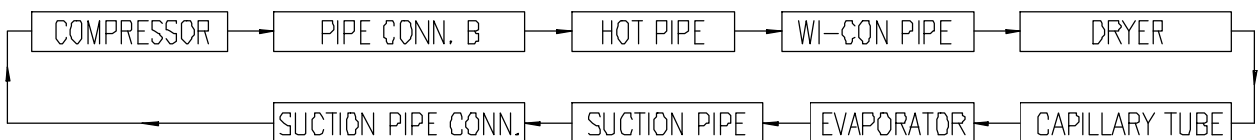
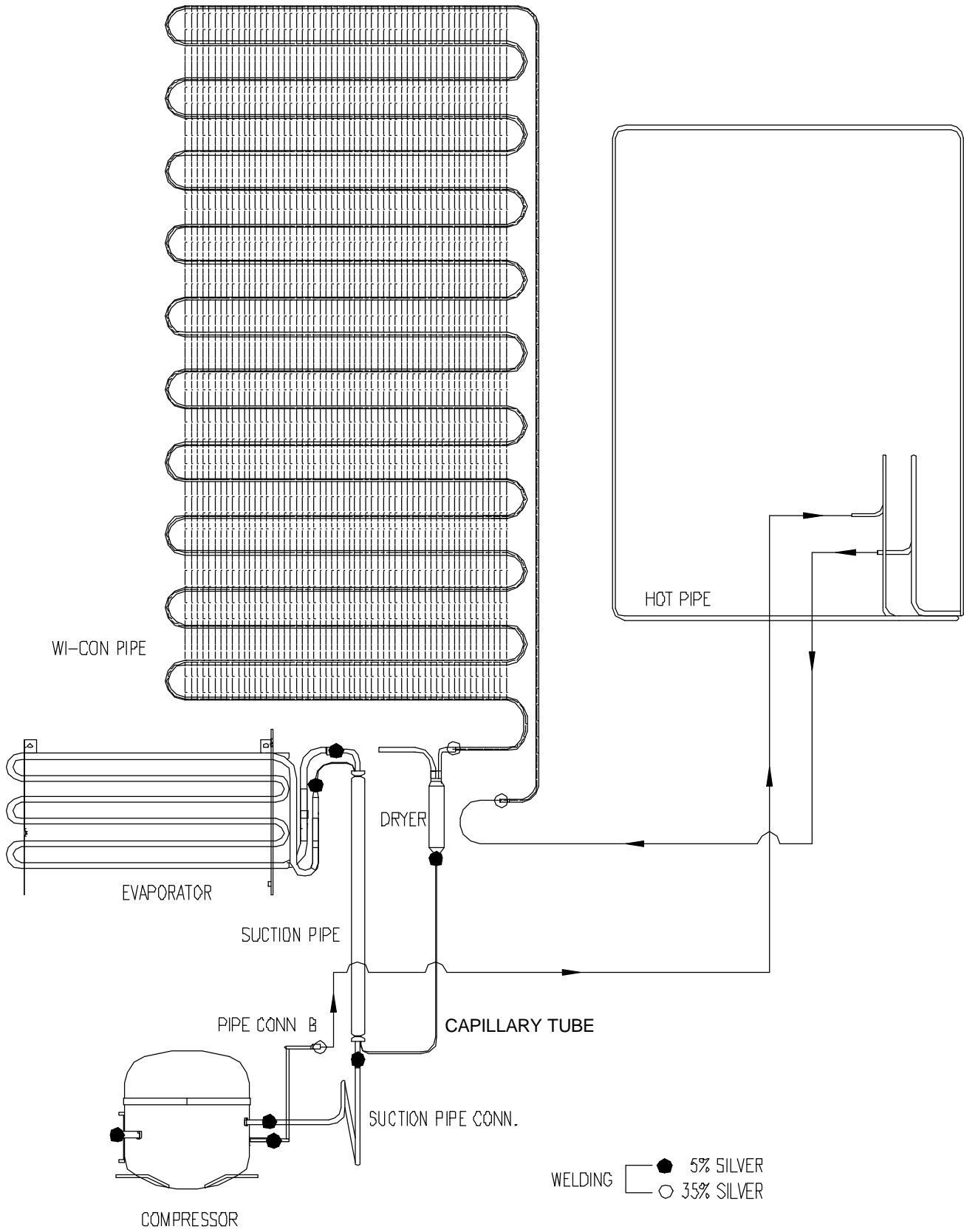

6. TEMPERATURES DIAGRAM

Refrigerator

SUPER : 0 °C
HIGH : 1 °C
MID : 3 °C
LOW : 5 °C
VAC : 6 °C

Low temp compartment : 3 °C

Vegetables compartment: 0 °C~5 °C

Freezer:

SUPER : -23 °C
HIGH : -22 °C
MID : -20 °C
LOW : -18 °C
VAC : -16 °C

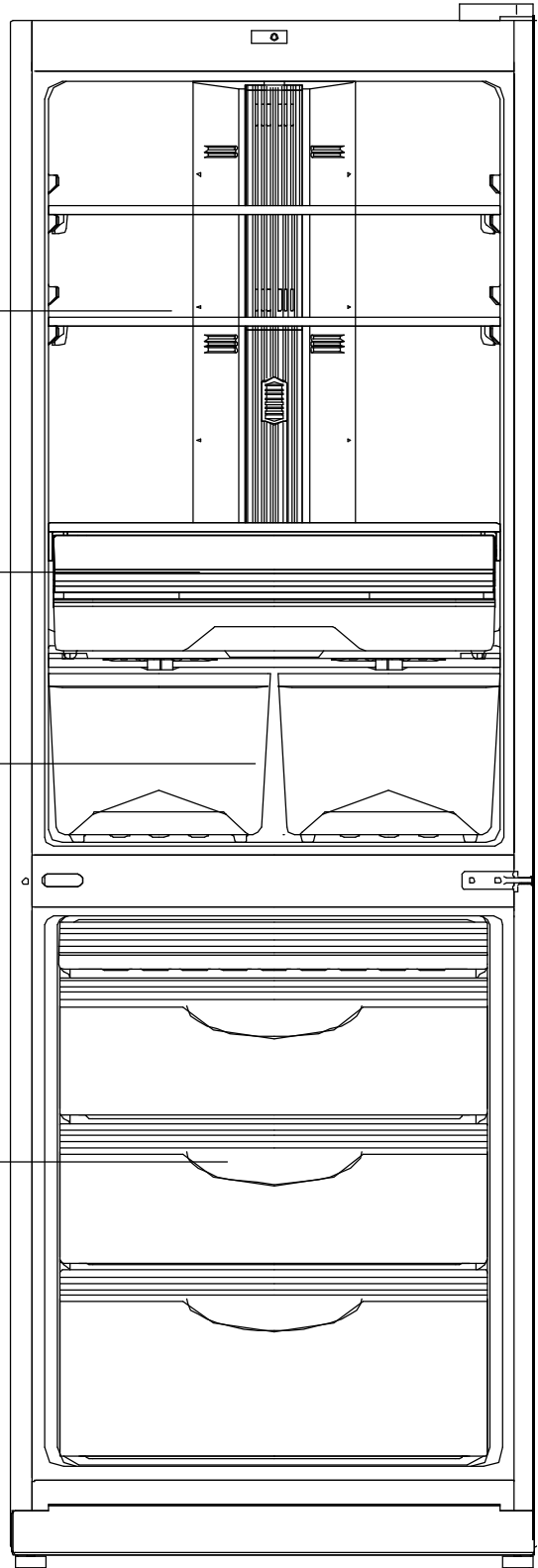

7. WIRING DIAGRAMS

7.1- ERF-XX6A

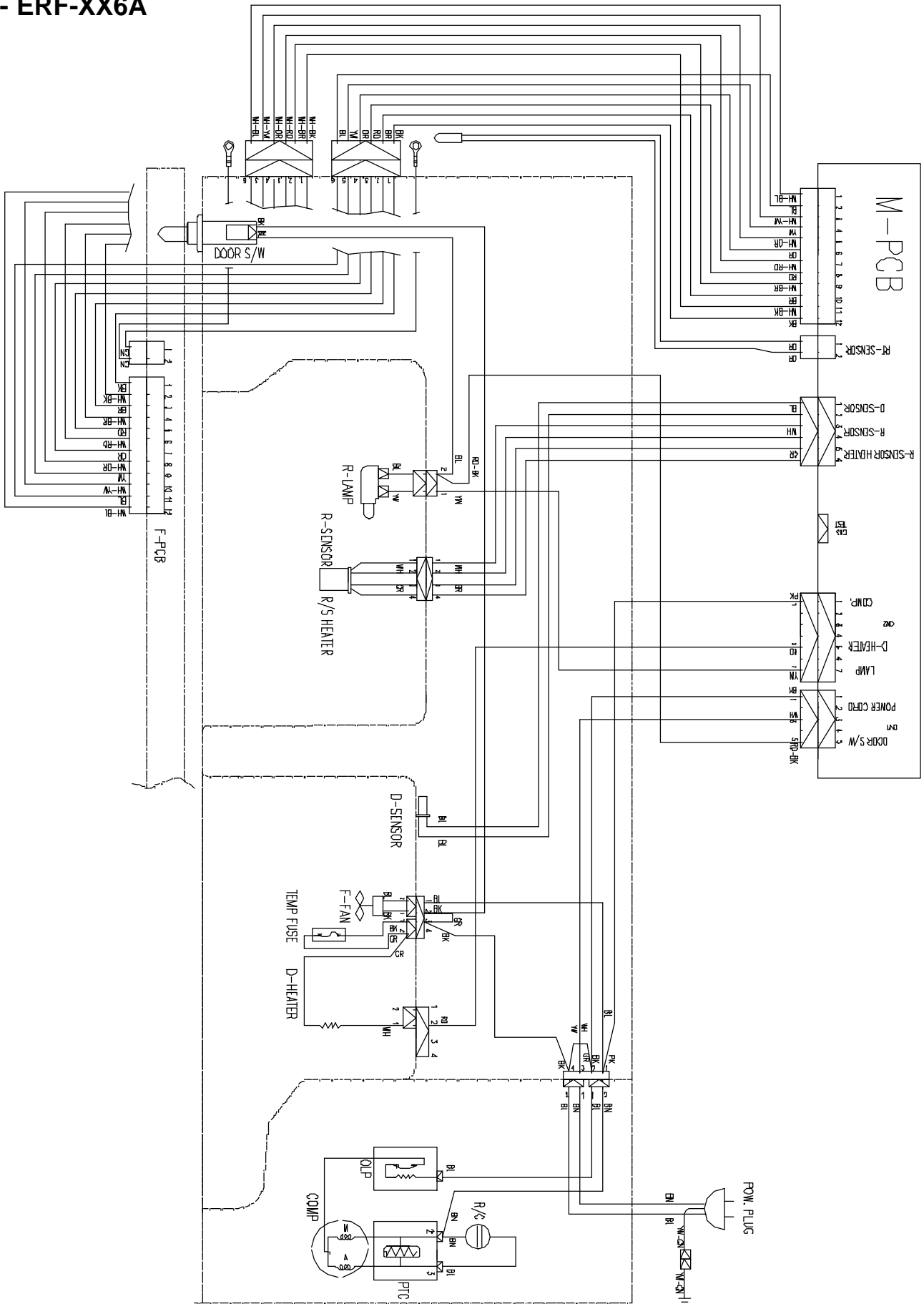

7.2- ERF-XX6N

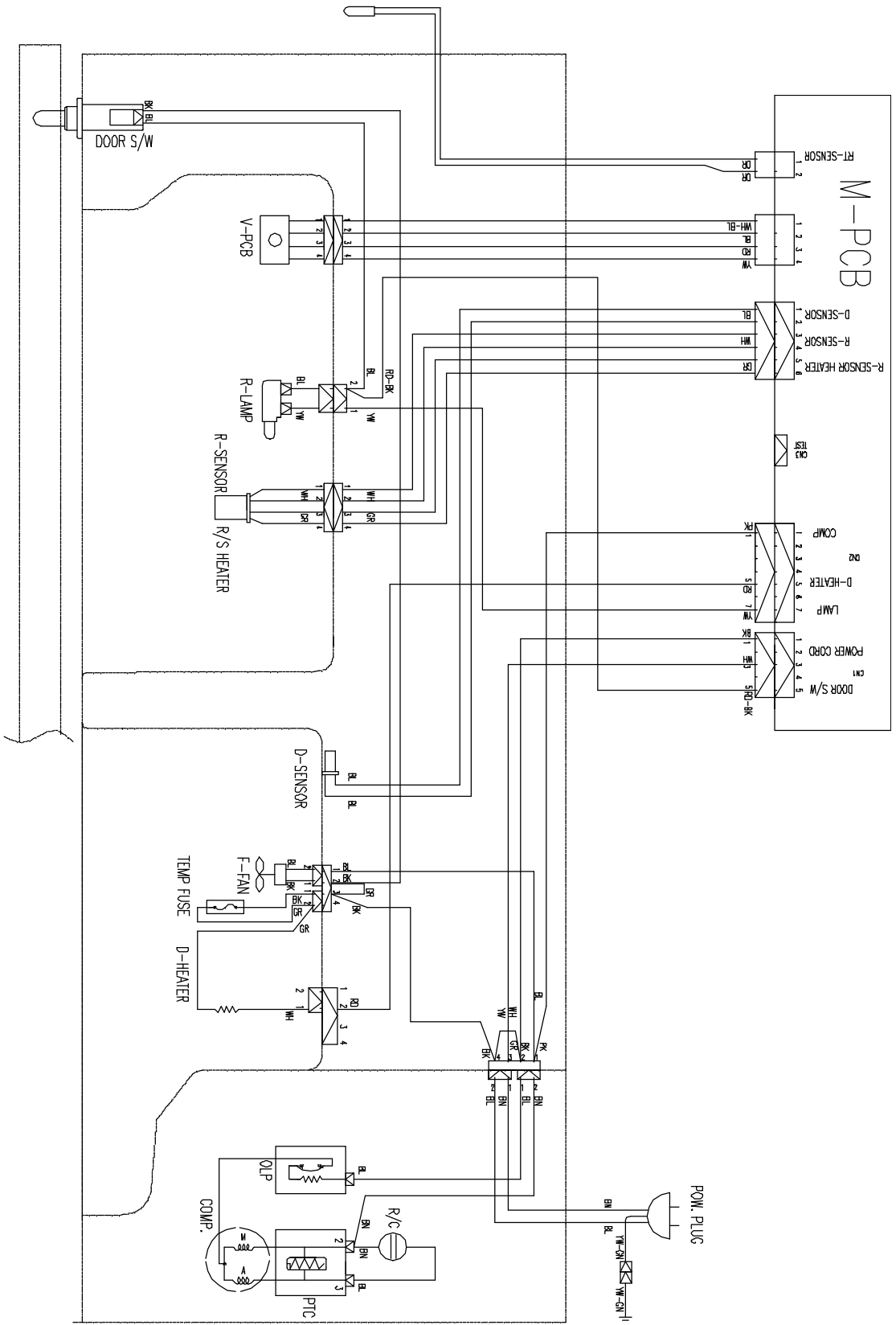

8. PCB CIRCUIT DIAGRAMS

8.1- ERF-XX6A

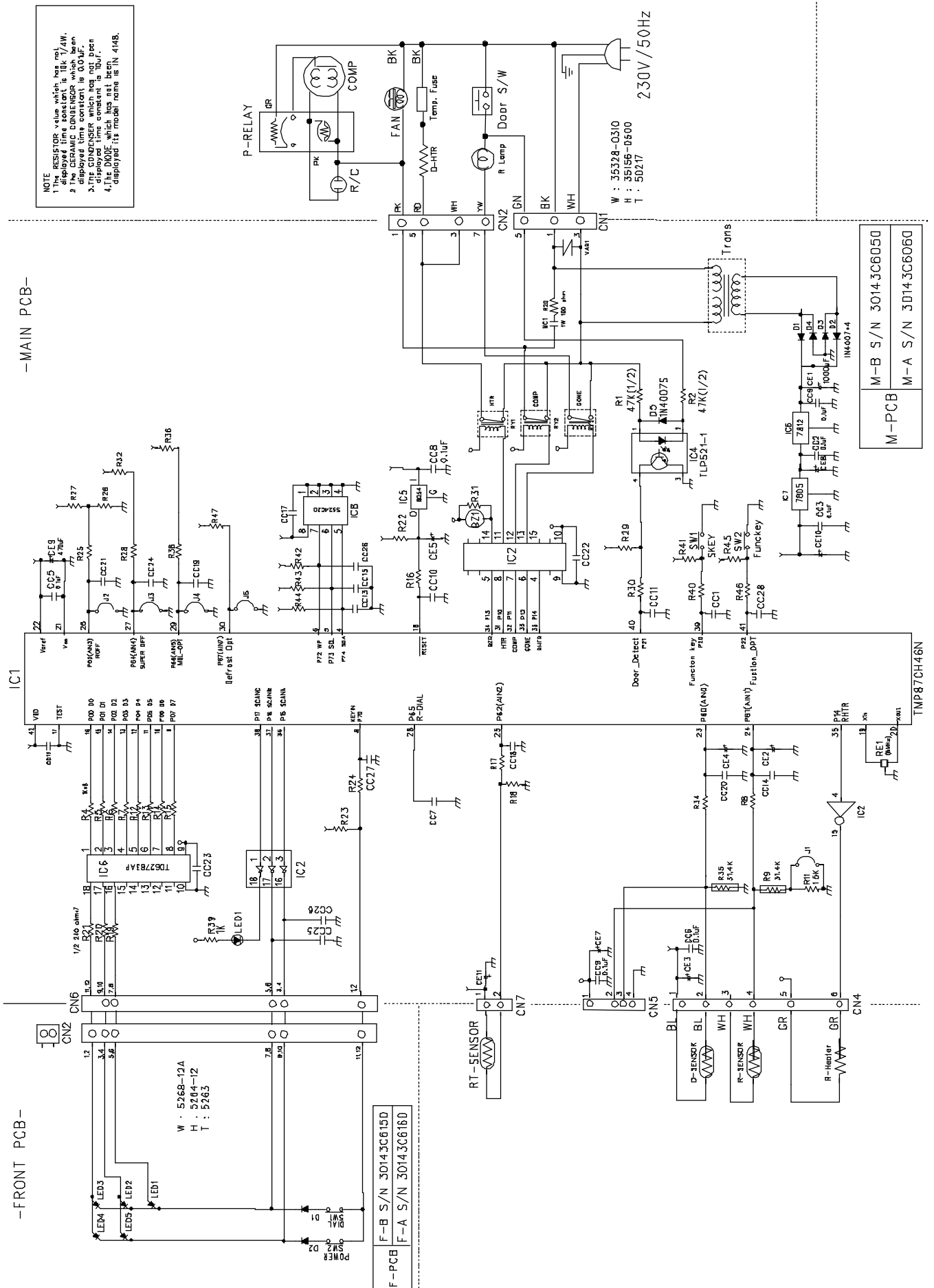

8.2- ERF-XX6N

- Volume PCB -

V-PCB	F-B S/N 30143C6250
F-A S/N 30143C6260	

W : 5267-04A
H : 5264-04
T : 5263

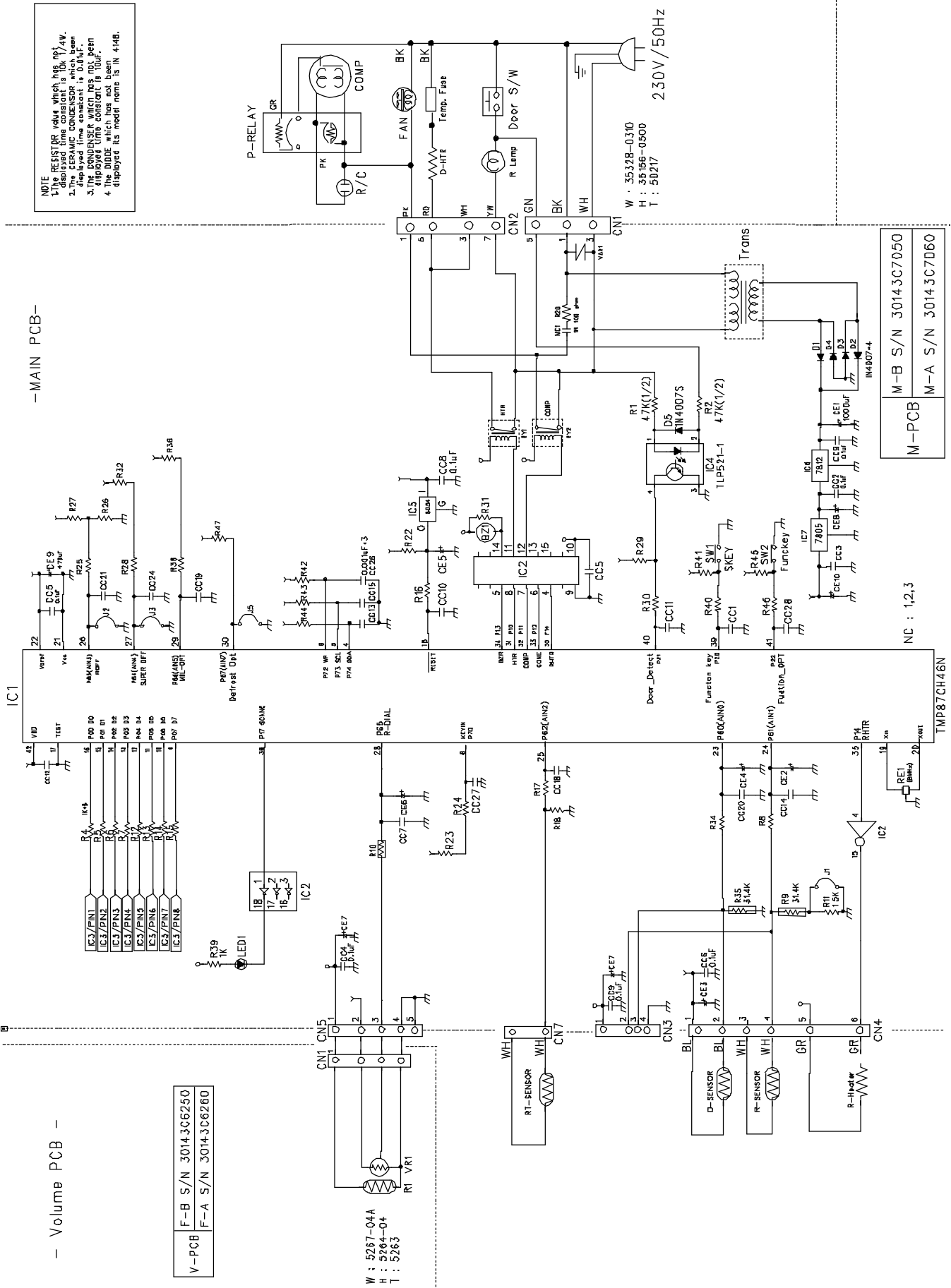

- MAIN PCB -

M-PCB	M-B S/N 30143C7050
M-A S/N 30143C7060	

ND : 1,2,3

TMP87CH46N

9. COMPONENTS DISASSEMBLY PICTURES

1- FRONT PCB (FULL AUTOMATIC TYPE)

- Input a cutter sleeve between Window FCP and Panel F control.

Important: Input carefully cutter in the area that picture shows (down right).



- Lift Window FCP up.

* Remark: Input cutter deeply and carefully in order to lift up easily and avoid paint damages and scratches.



- Unscrew Panel F Control.

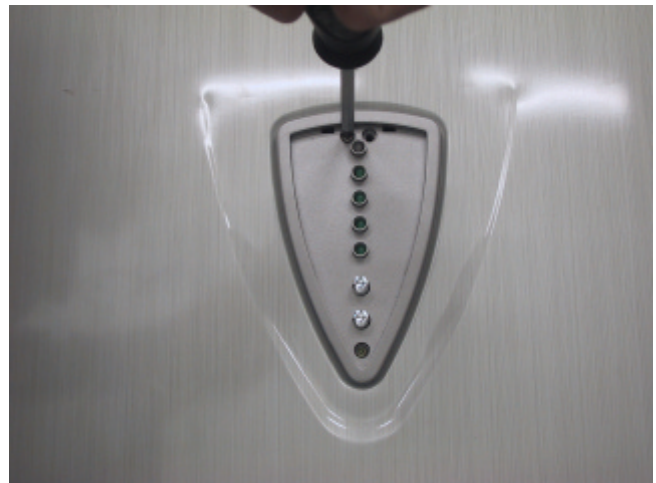

- Unscrew the two fixing screws of F-PCB as.

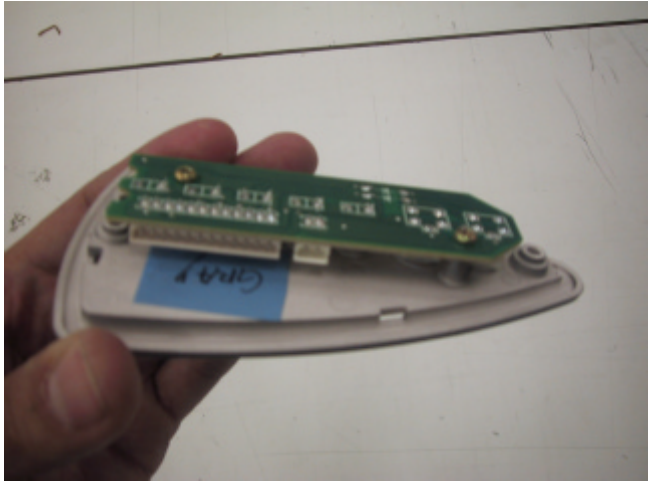

2- SWITCH DOOR

- Force switch door to the left side and input a thin driver in the right part as picture shows. After this operation, lift switch up.

* Remark: Input driver carefully in order to lift up easily and avoid paint damages and scratches.

- move switch to left side.

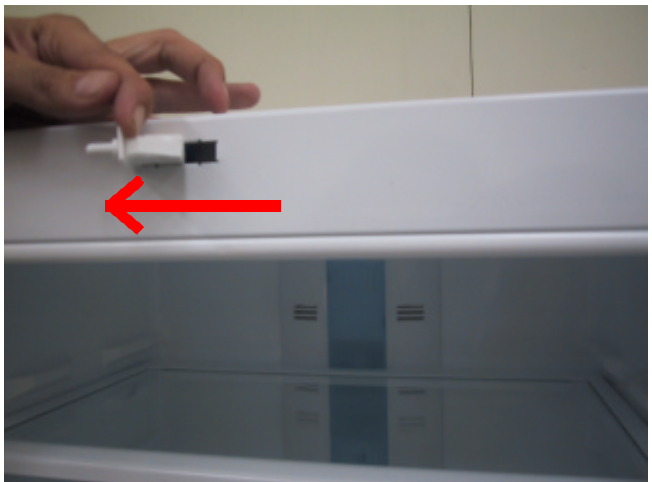
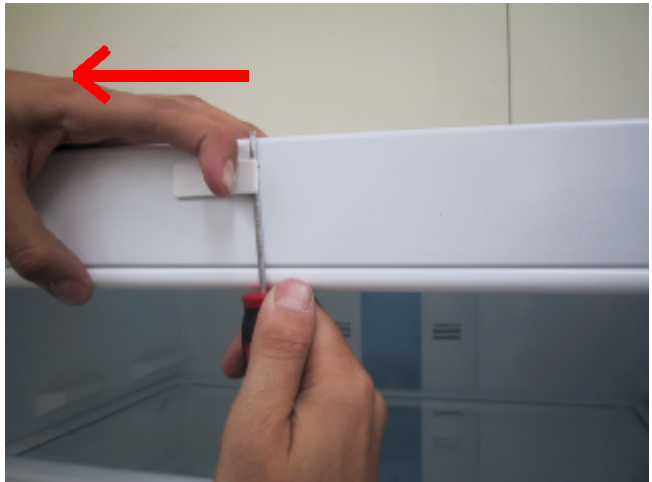

- Take out switch and disconnect housing.



3- M-PCB

- Unscrew the two fixing screws of cover PCB box.



- Disconnect all housings connectors from M-pcb, and force plastic locker of pcb box in order to take out the pcb.

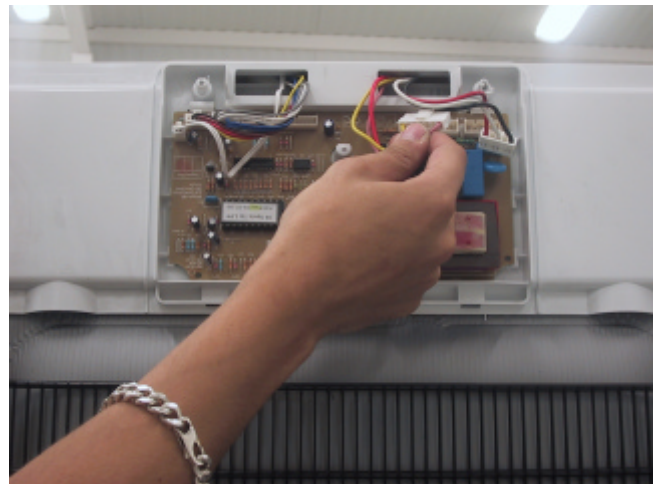

* Remark: In ERF-xx6N models forced defrost button is located in M-PCB, so pcb box cover must be disassembled

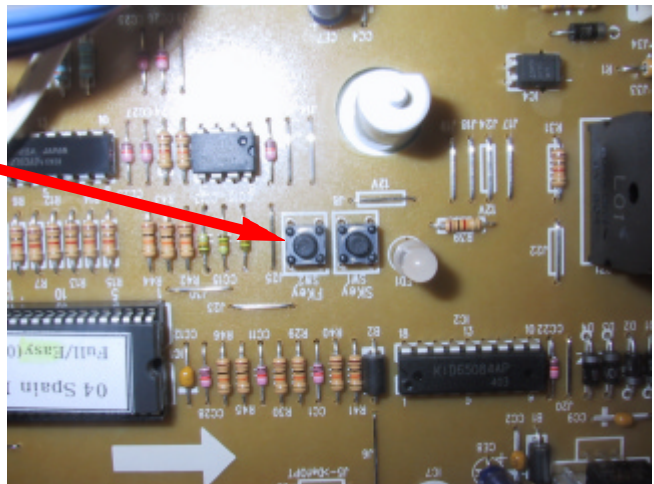

4- RELAY BOX COVER

- Press relay box cover stopper sleeve with a minus driver like picture shows.



5- MULTI DUCT

- Take out window r pulling the top part sleeve.



- Unscrew all fixing screws



- To disassemble V-PCB force left plastic stopper and lift pcb up.

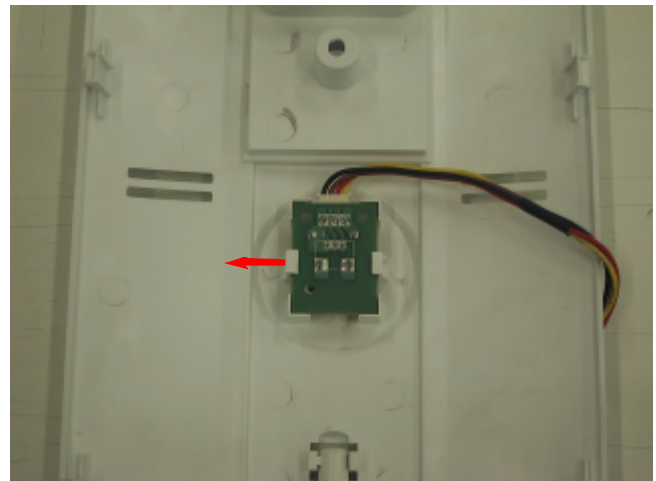

- To disassemble R-sensor lift it up from the wires carefully.



6- LOUVERS:

- Unscrew the two fixing screw for disassembly louver A and B



- Disconnect fan motor housing



- Unscrew the fixing screw in order to disassemble Louver A.

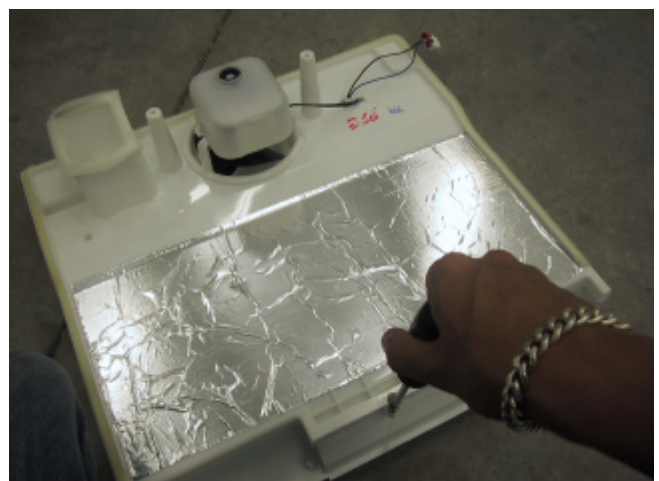

- When louvers are disassembled is very important check Knob F louver position.

Default position is M

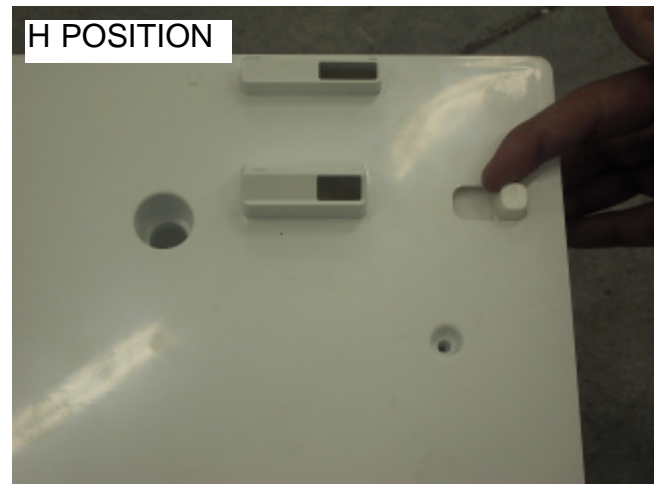
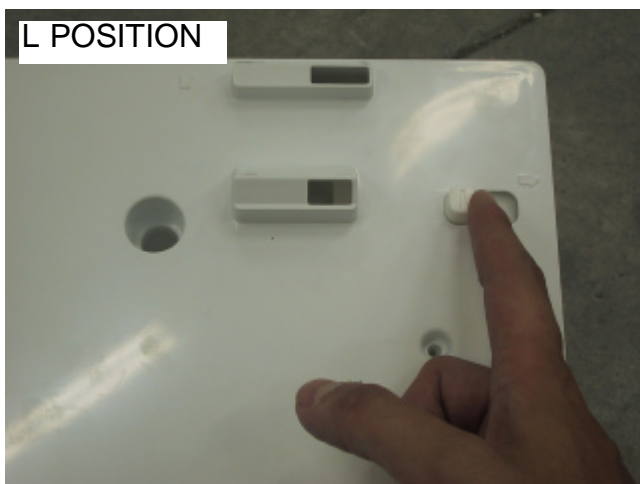
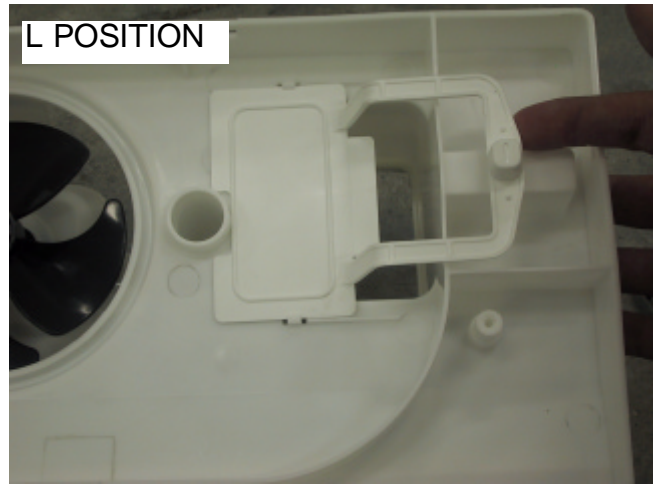

7-CHANGE DOOR OPEN SIDE

- Unscrew cover T hinge

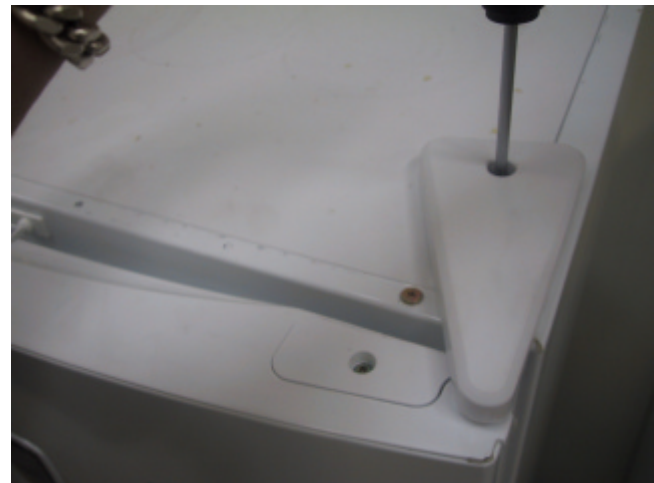

- Before changing door open side, disconnect door housing connector.

Follow next sheets instructions to change door open side

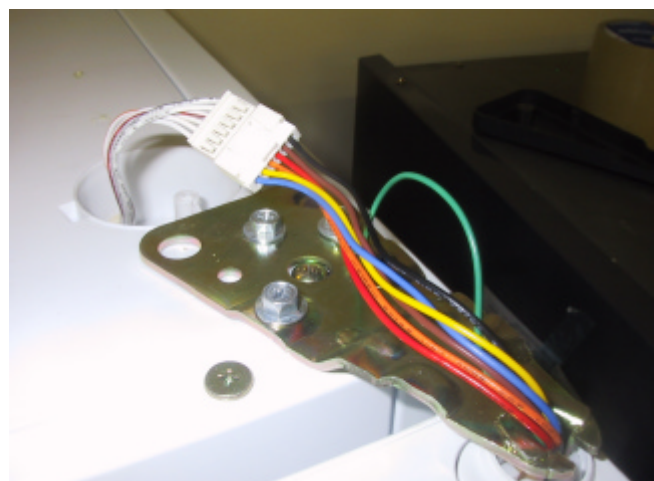

10. DOOR POSITION CHANGE PROCESS

STEP 1 : Remove door

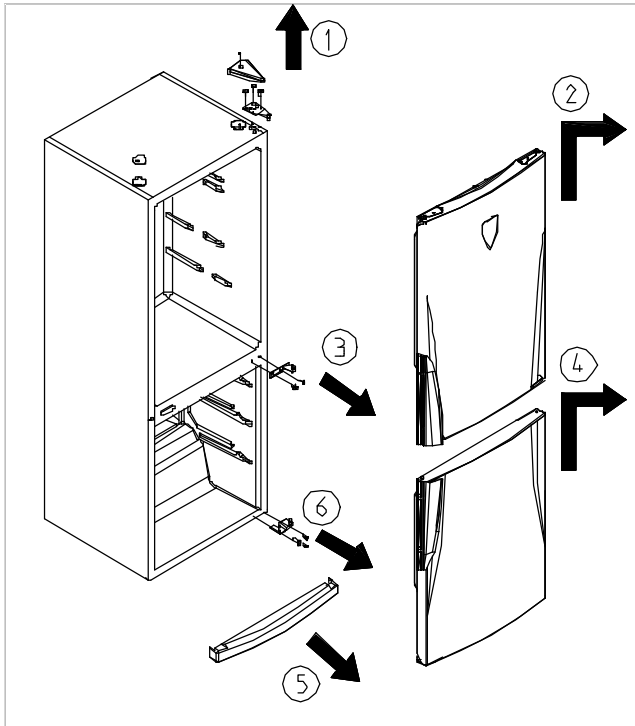

Follow to remove

1. Remove "COVER HINGE" and "HINGE T"
2. Remove "R" door.
3. Remove "HINGE M"
4. Remove "F" door
5. Remove "COVER BRACKET"
6. Remove "HINGE U"

STEP 2 : Change door handle

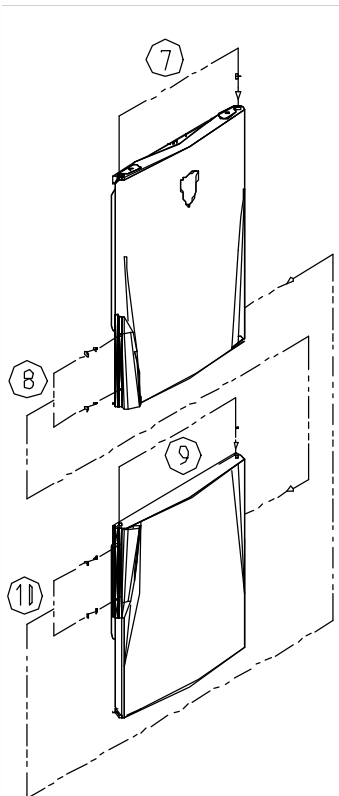

7. Reverse the position of "COVER BUSHING"
8. Move "R DOOR HANDLE" to "F DOOR"
9. Reverse the position of "CAP DR BUSHING"
10. Move "F DOOR HANDLE" to "R DOOR"

STEP 3 : Change door open side

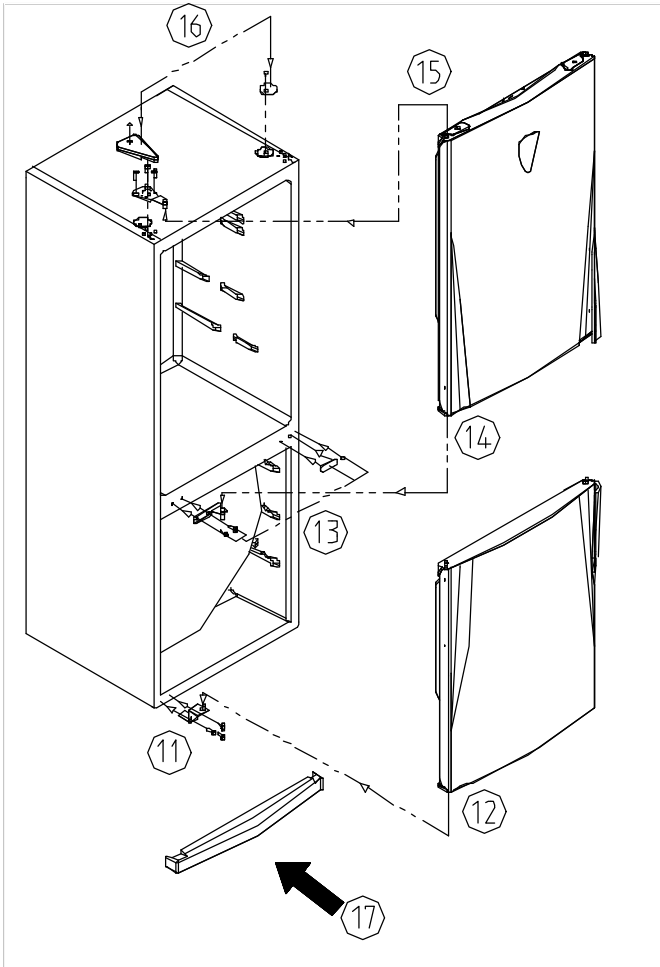

11. Attach the “HINGE U” on the left.

12. Attach the “F DOOR”

13. Reverse the position of “HINGE M” and
“CAP SCREW HOLE”

1. Attach the “R DOOR”

15. Attach the “HINGE T” on the left
of cabinet
after assembling to “R DOOR”

16. Reverse the position of “COVER
HINGE”
and “COVER CAB HARNESS”

11. EXPLODE DRAWING

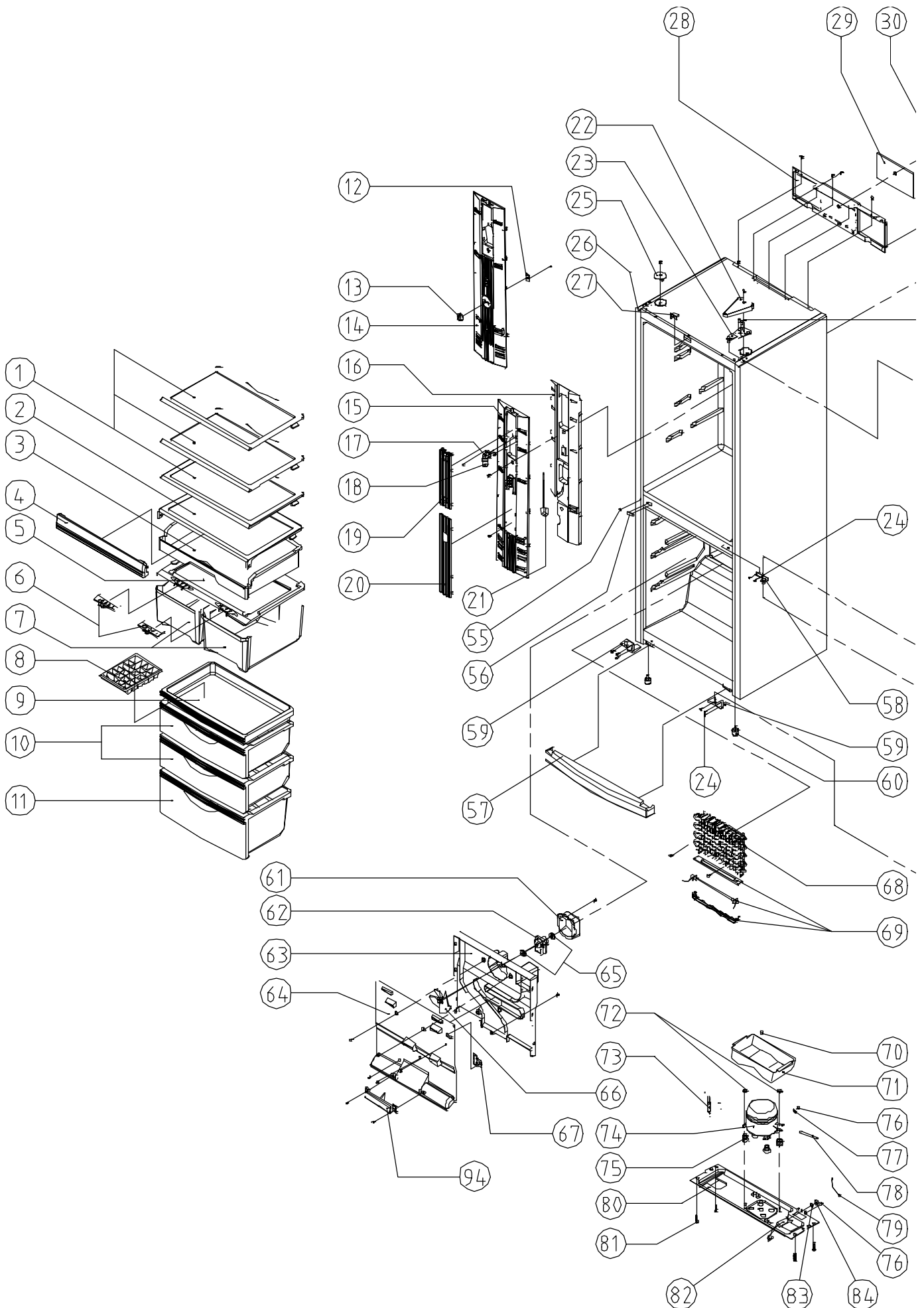

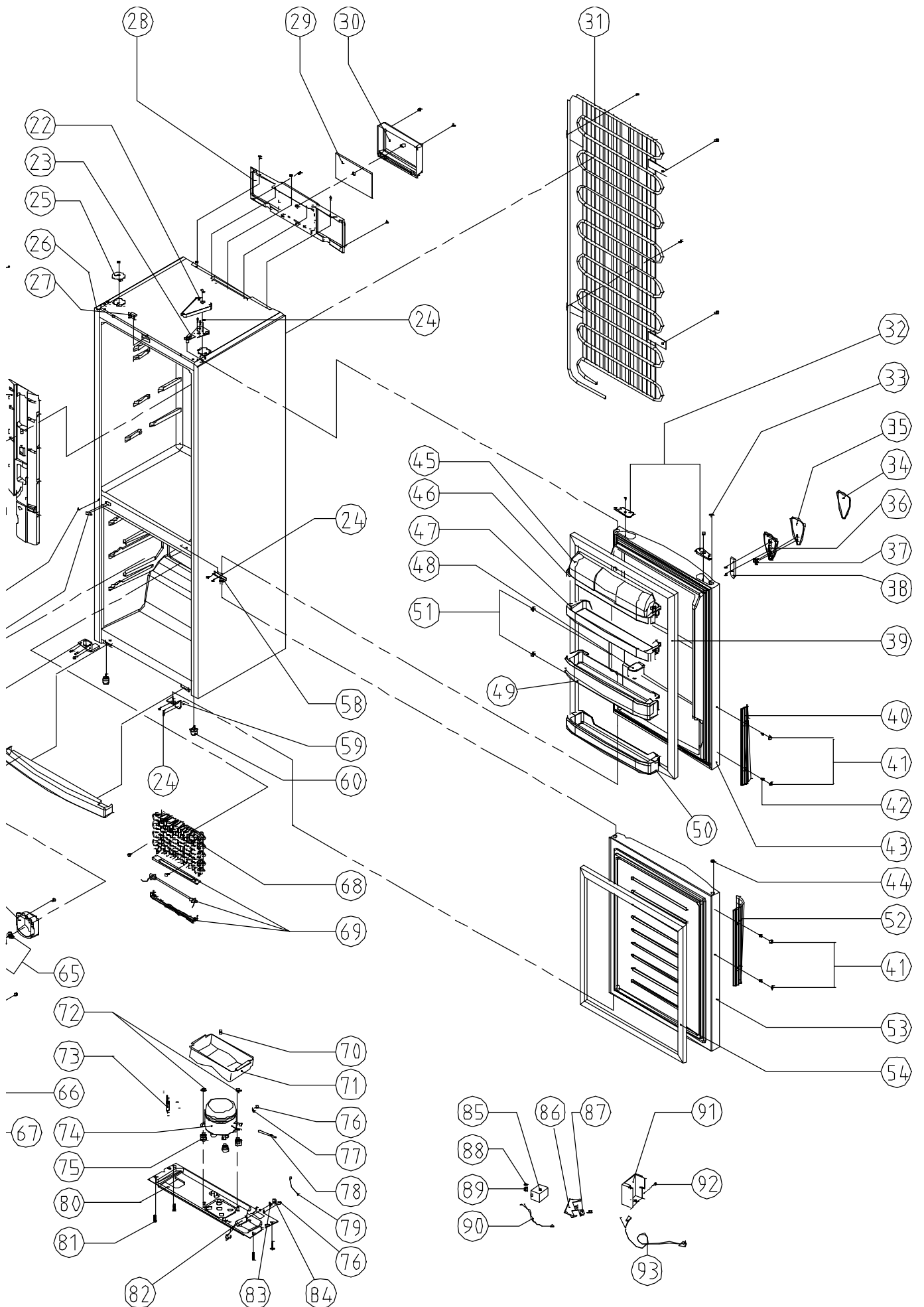

12. PARTS LIST











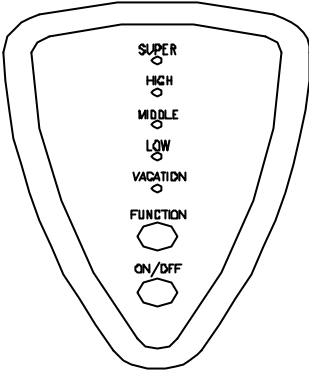
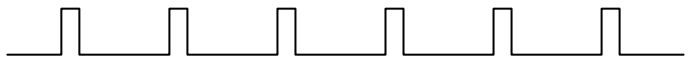

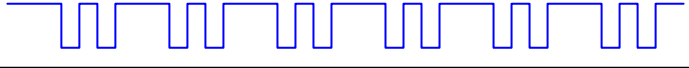
NO	PART NAME	PART CODE	MODEL						REMARK
			366N	366A	396N	396A	416N	416A	
1	SHELF GLAS AS	3017839400	2	2	3	3	3	3	
2	COVER GLAS C/C AS	3011497900	1	1	1	1	1	1	
3	CASE CHILD	3011181400	1	1	1	1	1	1	NANO SILVER
4	DOOR CHILLED CASE	3011760500	1	1	1	1	1	1	NANO SILVER
5	COVER VEGTB CASE	3011497700	1	1	1	1	1	1	
6	KNOB HUMIDITY	3013410800	2	2	2	2	2	2	
7	CASE VEGETABLE *L	3011181900	1	1	1	1	1	1	NANO SILVER
	CASE VEGETABLE *R	3011182000	1	1	1	1	1	1	NANO SILVER
8	CASE ICING	3011163200	1	1	1	1	1	1	
9	CASE F D	3011181800	1	1	1	1	1	1	
10	CASE F B AS	3011184900	2	2	-	-	-	-	BLUE MILKY
	CASE F C AS	3011185000	-	-	2	2	2	2	BLUE MILKY
11	CASE F A AS	3011184800	1	1	1	1	1	1	BLUE MILKY
12	V-PCB AS	30143C6260	1	-	1	-	1	-	
13	KNOB R CONTROL	3013410900	1	-	1	-	1	-	
14	COVER MULTI DUCT	3011495700	1	-	-	-	-	-	
15	COVER MULTI DUCT	3011495600	-	1	-	-	-	-	
14	COVER MULTI DUCT	3011495900	-	-	1	-	1	-	
15	COVER MULTI DUCT	3011495800	-	-	-	1	-	1	
16	INSU MULTI DUCT	3013353800	1	1	-	-	-	-	
16	INSU MULTI DUCT	3013353900	-	-	1	1	1	1	
17	SOCKET LAMP AS	3017903900	1	1	1	1	1	1	
18	LAMP	3013600700	1	1	1	1	1	1	
19	WINDOW R	3015510100	1	1	1	1	1	1	BLUE MILKY
20	DECO M/DUCT COVER	3011633200	-	1	-	1	-	1	BLUE
21	SENSOR R AS	3012731800	1	1	1	1	1	1	
22	COVER *T HINGE	DMS1494310	1	1	1	1	1	1	SNOW WHITE
		DMS1494320	1	1	1	1	1	1	03 SILVER
23	HINGE *T AS	3012922600	1	1	1	1	1	1	
24	SPECIAL BOLT C	3016004900	11	11	11	11	11	11	
25	COVER CAB HARNESS	DMS1477510	1	1	1	1	1	1	SNOW WHITE
		DMS1477520	1	1	1	1	1	1	03 SILVER
26	ASSY CAB URT	-	1	1	-	-	-	-	
		-	-	-	1	1	-	-	
		-	-	-	-	-	1	1	
27	SWITCH DOOR	3011755200	1	1	1	1	1	1	WHITE
		3011762900	1	1	1	1	1	1	03 SILVER
28	BOX PCB	3010545300	1	1	1	1	1	1	03 SILVER
		DMS0545310	1	1	1	1	1	1	SNOW WHITE
29	M-PCB AS	30143C6060	-	1	-	1	-	1	
		30143C7060	1	-	1	-	1	-	
30	COVER PCB BOX	3011477600	1	1	1	1	1	1	03 SILVER
		DMS1477610	1	1	1	1	1	1	SNOW WHITE
31	PIPE WI-CON AS	3014434500	1	1	1	1	1	1	
32	COVER HRNS*R	3011477100	1	1	1	1	1	1	03 SILVER
		DMS1477110	1	1	1	1	1	1	SNOW WHITE
	COVER HRNS*L	3011477200	1	1	1	1	1	1	03 SILVER
		DMS1477210	1	1	1	1	1	1	SNOW WHITE
33	COVER BUSH	3011498200	1	1	1	1	1	1	03 SILVER
		DMS1498210	1	1	1	1	1	1	SNOW WHITE
34	WINDOW FCP B	3015510000	1	-	1	-	1	-	
35	WINDOW FCP A	3015509900	-	1	-	1	-	1	
36	PANEL *F CONTROL	3014234000	-	1	-	1	-	1	03 SILVER
		DMS4234010	-	1	-	1	-	1	SNOW WHITE

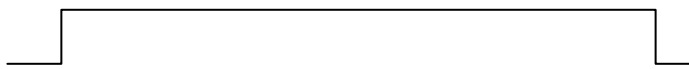
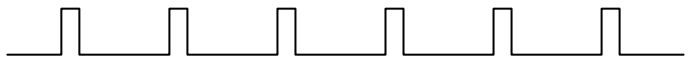
NO	PART NAME	PART CODE	MODEL						REMARK
			366N	366A	396N	396A	416N	416A	
37	BUTTON F-CP	3016304300	-	1	-	1	-	1	
38	F-PCB AS	30143C6160	-	1	-	1	-	1	
39	GASKET R DOOR AS	3012306600	1	1	-	-	-	-	
		3012306800	-	-	1	1	1	1	
40	HANDLE R	3012640000	1	1	1	1	1	1	03 SILVER
		DMS2640010	1	1	1	1	1	1	SNOW WHITE
41	COVER HNDL SCREW	3011495200	4	4	4	4	4	4	03 SILVER
		DMS1495210	4	4	4	4	4	4	SNOW WHITE
42	SPECIAL SCREW	3016033600	4	4	4	4	4	4	
43	ASSY R DR A/S 366A SW	DMS0060000	-	1	-	-	-	-	GRIP S-WHITE
	ASSY R DR A/S 366A SV	DMS0060010	-	1	-	-	-	-	GRIP SILVER
	ASSY R DR A/S 366N SW	DMS0060100	1	-	-	-	-	-	GRIP S-WHITE
	ASSY R DR A/S 366N SV	DMS0060110	1	-	-	-	-	-	GRIP SILVER
	ASSY R DR A/S 396A 416A SW	DMS0061000	-	-	-	1	-	1	GRIP S-WHITE
	ASSY R DR A/S 396A 416A SV	DMS0061010	-	-	-	1	-	1	GRIP SILVER
	ASSY R DR A/S 396N 416N SW	DMS0061100	-	-	1	-	1	-	GRIP S-WHITE
	ASSY R DR A/S 396N 416N SV	DMS0061110	-	-	1	-	1	-	GRIP SILVER
44	CAP DR BUSHING	3010967400	1	1	1	1	1	1	SNOW WHITE.
		DMS0967420	1	1	1	1	1	1	03 SILVER
45	COVER DAIRY POCKET	3011495000	1	1	1	1	1	1	BLUE MILKY
46	POCKET DAIRY	3019025000	1	1	1	1	1	1	
47	POCKET R	3019025200	1	1	1	1	1	1	
48	GUIDE BOTTLE POCKET	3012523800	1	1	1	1	1	1	BLUE MILKY
49	POCKET BOTL AS	3019026100	1	1	1	1	1	1	BLUE MILKY
50	POCKET MULTI AS	3019026200	1	1	1	1	1	1	BLUE MILKY
51	CAP HANDLE	3010910000	4	4	4	4	4	4	SNOW WHITE
		DMS0910030	4	4	4	4	4	4	03 SILVER
52	HANDLE F	3012639800	1	1	1	1	1	1	03 SILVER
		DMS2639810	1	1	1	1	1	1	SNOW WHITE
53	ASSY F DR A/S 366 396 SW	DMS0062000	1	1	1	1	-	-	GRIP S-WHITE
	ASSY F DR A/S 366 396 SV	DMS0062010	1	1	1	1	-	-	GRIP SILVER
	ASSY F DR A/S 416 SW	DMS0062100	-	-	-	-	1	1	GRIP S-WHITE
	ASSY F DR A/S 416 SV	DMS0062110	-	-	-	-	1	1	GRIP SILVER
54	GASKET F DOOR AS	3012306500	1	1	1	1	-	-	
		3012306700	-	-	-	-	1	1	
55	CAP SCREW	3010920200	1	1	1	1	1	1	SNOW WHITE
		DMS0920220	1	1	1	1	1	1	03 SILVER
56	CAP SCREW HOLE	3010920300	1	1	1	1	1	1	
57	COVER CAB BRACKET	3011494900	1	1	1	1	1	1	SNOW WHITE
		DMS1494910	1	1	1	1	1	1	03 SILVER
58	HINGE *M	3012908002	1	1	1	1	1	1	
59	HINGE *U	DMS2908201	1	1	1	1	1	1	
60	FOOT ADJUSTING AS	3012101800	2	2	2	2	2	2	
61	BRACKET FAN MOTOR	3010615600	1	1	1	1	1	1	
62	MOTOR FAN AS	3011804710	1	1	1	1	1	1	
63	LOUVER F B	3018918900	1	1	1	1	-	-	
63	LOUVER F B	3018919000	-	-	-	-	1	1	
64	LOUVER F A	3018918700	1	1	1	1	-	-	
64	LOUVER F A	3018918800	-	-	-	-	1	1	
65	BUSHING FAN MOTOR	3010701800	2	2	2	2	2	2	
66	FAN	3011801410	1	1	1	1	1	1	
67	KNOB F LOUVER	3013410700	1	1	1	1	1	1	
68	EVAPORATOR AS	3017045600	1	1	1	1	1	1	
69	HEATER D AS	3012807651	1	1	1	1	1	1	
70	CAP DRAIN HOSE	3010919700	1	1	1	1	1	1	

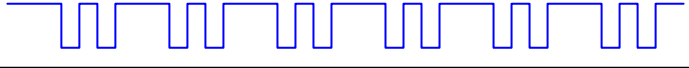
NO	PART NAME	PART CODE	MODEL						REMARK
			366N	366A	396N	396A	416N	416A	
71	CASE VAPORY	3011162700	1	1	1	1	1	1	
72	FIXTURE COMP	3012005300	2	2	2	2	2	2	
73	DRYER ASSY	3016802203	1	1	1	1	1	1	
74	COMPRESSOR	DMS0A00100	1	1	1	1	1	1	
75	ABSORBER COMP	3010103400	4	4	4	4	4	4	
76	SCREW MACHINE	DMS1B00100	1	1	1	1	1	1	
77	SPECIAL WASHER	DMS1B00200	1	1	1	1	1	1	
78	PIPE CHARGE	3014418211	1	1	1	1	1	1	
79	HARNESS EARTH	3012735220	1	1	1	1	1	1	
80	BASE COMP	-	1	1	1	1	1	1	
81	SPECIAL SCREW A	3016004300	4	4	4	4	4	4	
82	CAPACITOR RUN	DMS6402129	1	1	1	1	1	1	
83	SPECIAL WASHER R/C	DMS6006510	1	1	1	1	1	1	
84	SPECIAL NUT R/C	DMS6006410	1	1	1	1	1	1	
85	RELAY BOX	DMS0527900	1	1	1	1	1	1	
86	CLAMP CORD A	DMS1200100	1	1	1	1	1	1	
87	CLAMP CORD B	DMS1200200	1	1	1	1	1	1	
88	SWITCH P RELAY OL	DMS1A00100	1	1	1	1	1	1	
89	SWITCH P RELAY PTC	DMS1C00100	1	1	1	1	1	1	
90	HARNESS RELAY	3012731901	1	1	1	1	1	1	
91	COVER MECH HOUSING	3011454100	1	1	1	1	1	1	
92	SCREW TAPPING	7112401011	1	1	1	1	1	1	
93	CORD POWER AS	3011343340	1	1	1	1	1	1	COMMON
94	LOUVER F C	3018920700	1	1	1	1	1	1	

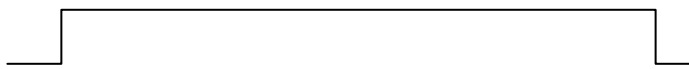
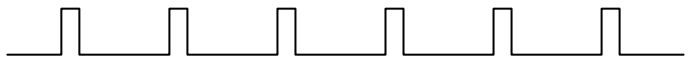
13. PCB CONTROL FUNCTION

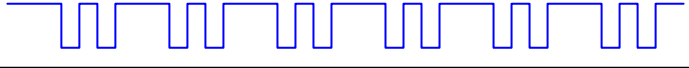
13.1. ERF-XXXA

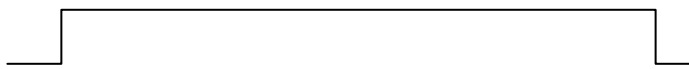
NO	FUNCTION	CONTENTS														
1.	DISPLAY	<div style="text-align: center;">  </div> <p>1) VAC STEP LED ON: WHEN TEMP CONTROL S/W IS PRESSED 1 TIME. 2) LOW STEP LED ON: WHEN TEMP CONTROL S/W IS PRESSED 2 TIMES. 3) MID STEP LED ON: WHEN TEMP CONTROL S/W IS PRESSED 3 TIMES. 4) HIGH STEP LED ON: WHEN TEMP CONTROL S/W IS PRESSED 4 TIMES. 5) SUPER STEP LED ON: WHEN TEMP CONTROL S/W IS PRESSED 5 TIMES. 6) ERROR LED DISPLAY (ON MAIN PCB)</p> <table border="1" style="width: 100%; border-collapse: collapse;"> <thead> <tr> <th style="width: 50%;">DISPLAY</th> <th style="width: 50%;">Led Output Wave Form</th> </tr> </thead> <tbody> <tr> <td>D1 ERROR</td> <td></td> </tr> <tr> <td>D2 ERROR</td> <td></td> </tr> <tr> <td>R1 ERROR</td> <td></td> </tr> <tr> <td>RT ERROR</td> <td></td> </tr> <tr> <td>EP ERROR</td> <td></td> </tr> <tr> <td>DR ERROR</td> <td></td> </tr> </tbody> </table> <p>? FUNCTION DISPLAY</p> <ul style="list-style-type: none"> - D1 ERROR : LED is off & on one time. - D2 ERROR : LED is off & on two times. - R1 ERROR : LED is on & off one time. - RT ERROR : LED is on & off two times. - EP ERROR : LED is on & off continually - DR ERROR : LED is on continually - FORCED DEFROST OF CONDITION:HIGH, LOW led Lamps are on - SHORT CIRCUIT OF CONDITION: SUPER, MIDDLE, VAC led Lamps are on 	DISPLAY	Led Output Wave Form	D1 ERROR		D2 ERROR		R1 ERROR		RT ERROR		EP ERROR		DR ERROR	
DISPLAY	Led Output Wave Form															
D1 ERROR																
D2 ERROR																
R1 ERROR																
RT ERROR																
EP ERROR																
DR ERROR																

2.	TEMPERATURE ADJUSTMENT & CONTROL	<p>1) TEMP. CONTROL SWITCH</p> <p>1.1- TEMP. CONTROL When TEMP CONTROL button is pressed, the led lamps MIDLE - HIGH - SUPER - VAC -LOW - MIDDLE will be on in sequence. TEMPERATURE will be set if the button doesn't get pressed again within 5 sec</p> <p>1.2- FORCED DEFROST: will be start when this button pushed for over 5 seconds continuously.</p> <p>1.3- SHORT CIRCUIT OPERATION: will be started and stopped when this button pushed over 30 fmes.</p> <p>2) TEMPERATURE CONTROL</p> <p>2.1- COMP will be controlled by the on/off condition of each mode.</p> <p>2.2- STEP DIFF of ROOM R : Vac/Low - 1.75 deg, Low/Middle - 0.7deg, Mid/High - 1.05deg, High/Super - 1.4 deg</p> <p>2.3- OFF point of ROOM R in MID position: -0.5°C</p> <p>2.4- ON/OFF DIFF of ROOM R: 3°C</p> <p>3) FORCED DEFROST</p> <p>3.1- Defrost mode will be Started independent of the cycle.</p> <p>3.2- The flow is same as the general defrost mode flow.</p> <p>4) SHORT CIRCUIT OPERATION</p> <p>4.1- COMP & FAN will be on independent of the operation condition.</p> <p>4.2- The time limit of SHORT CIRCUIT OPERATION: 60 hrs</p>
3.	VACATION	<p>- Press TEMP. CONTROL SWITCH and make VAC led lamp on.</p> <p>ON POINT: 4.95°C</p> <p>OFF POINT: 1.95°C</p>





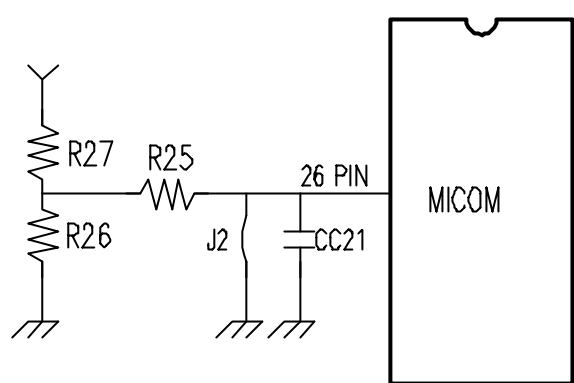

4.	SUPER	<p>- Press TEMP. CONTROL button and make SUPER led lamp on.</p> <p>ON POINT: 0.05°C</p> <p>OFF POINT: -2.95°C</p>																													
5.	Determination of DEFROST	<p>1) Starting condition of Defrost Mode</p> <p>1.1- When accumulated running time of comp. Is 8, 10, 12, 18, 30hrs.</p> <p>1.2- After Checking the condition '1.1' if total time (COMP on time + COMP off time) is more than 24, 36, 48, 72hrs, then defrost mode starts immediately.</p> <table border="1"> <thead> <tr> <th rowspan="2">RT-SENSOR</th> <th colspan="2">Accumulated running time of COMP</th> <th colspan="2">Total running time of COMP</th> </tr> <tr> <th>Door Open</th> <th>Door Close</th> <th>Door Open</th> <th>Door Close</th> </tr> </thead> <tbody> <tr> <td>RT 29°C Up</td> <td>8HR</td> <td>18HR</td> <td>24HR</td> <td>36HR</td> </tr> <tr> <td>20<RT< 28°C</td> <td>12HR</td> <td>30HR</td> <td>48HR</td> <td>72HR</td> </tr> <tr> <td>15<RT< 19°C</td> <td>8HR</td> <td>12HR</td> <td>24HR</td> <td>36HR</td> </tr> <tr> <td>RT 14°C Down</td> <td>8HR</td> <td>10HR</td> <td>24HR</td> <td>36HR</td> </tr> </tbody> </table>	RT-SENSOR	Accumulated running time of COMP		Total running time of COMP		Door Open	Door Close	Door Open	Door Close	RT 29°C Up	8HR	18HR	24HR	36HR	20<RT< 28°C	12HR	30HR	48HR	72HR	15<RT< 19°C	8HR	12HR	24HR	36HR	RT 14°C Down	8HR	10HR	24HR	36HR
RT-SENSOR	Accumulated running time of COMP			Total running time of COMP																											
	Door Open	Door Close	Door Open	Door Close																											
RT 29°C Up	8HR	18HR	24HR	36HR																											
20<RT< 28°C	12HR	30HR	48HR	72HR																											
15<RT< 19°C	8HR	12HR	24HR	36HR																											
RT 14°C Down	8HR	10HR	24HR	36HR																											
6.	DEFROST MODE	<p>1) General Defrost Mode</p> <p>1.1- Start: By determination of defrost</p> <p>1.2- Process: General operation- Heater on – Pause (6min) - General operation</p> <p>-Heater defrosts: When the temperature at D-sensor is over 10°C, heater turns off.</p> <p>-Limit time: 80 min (30 min on D SENSOR ERROR)</p> <p>2) Forced Defrost Mode</p> <p>2.1- Start: by press TEMP. CONTROL button for 5 seconds continuously.</p> <p>2.2- Process: same as General Defrost Mode</p> <p>-Heater is supposed to be on Initial 30 seconds. (for TEST)</p> <p>2.3- Display : led lamps 'LOW' 'HIGH' is on.</p>																													
7.	INITIAL DEFROST	<p>1) When power is on, if the temperature at the D-sensor is under 3.5°C, then General Defrost Mode starts.</p> <p>2) When initial defrost mode starts, heater will be on directly and defrost mode will be started.</p>																													
8.	PREVENTION OF COMP. RESTART	<p>COMP. doesn't work after COMP. turns off even though Rsensor is on condition. (This is to protect comp.)</p> <p>1) General operation : The COMP can't be on within 6 min.</p> <p>2) Operation of LOW RT : The COMP can't be on within 40 min.</p>																													

9.	ERROR DISPLAY & CONTROL	<p>- ERROR DISPLAY</p> <ul style="list-style-type: none"> - When error happens, it is displayed on led lamp.(Main PCB LED 1) <p>1) R1 ERROR (It happens when R-SENSOR is OPEN or SHORT)</p> <ul style="list-style-type: none"> 1.1- DISPLAY : On & off one time while LED is on. 1.2- CONTROL : Controlled by the condition of RT <p style="text-align: right;">(Unit : min)</p> <table border="1" data-bbox="459 488 1497 678"> <thead> <tr> <th data-bbox="459 488 932 584">RT-S TEMP</th> <th data-bbox="932 488 1118 584">RT-S ERROR</th> <th data-bbox="1118 488 1305 584">19°C Down</th> <th data-bbox="1305 488 1497 584">20°C Up</th> </tr> </thead> <tbody> <tr> <td data-bbox="459 584 932 678">COMP. Operating TIME (ON / OFF)</td> <td data-bbox="932 584 1118 678">20 / 30</td> <td data-bbox="1118 584 1305 678">15 / 35</td> <td data-bbox="1305 584 1497 678">22 / 28</td> </tr> </tbody> </table> <ul style="list-style-type: none"> 1.3- CANCEL : when R-SENSOR is working normally. <p>2) D1 ERROR (It happens when D-SENSOR is OPEN or SHORT)</p> <ul style="list-style-type: none"> 2.1- DISPLAY : On & off one time while LED is off. 2.2- CONTROL : Return to the limit defrost time of Defrost (30 min) <p>3) D2 ERROR (It happens when heater is off by time - 80 min).</p> <ul style="list-style-type: none"> 3.1- DISPLAY : On & off two times while LED is off. 3.2- CONTROL : Return to next limit defrost time (80 min) <p>4) RT ERROR (It happens when RTSENSOR is OPEN or SHORT)</p> <ul style="list-style-type: none"> 4.1- DISPLAY : On & off two times while LED is on. 4.2- CONTROL: The system is normally operating but the controlling by RT-SENSOR doesn't work. 4.3- CANCEL : when RT-SENSOR is working normally. <p>5) DR ERROR</p> <ul style="list-style-type: none"> 5.1- Display : LED is on continuously 5.2- Control : Deletion of function related door switch sensing 5.3- If door switch (open & close) is sensed, the error is terminated automatically 	RT-S TEMP	RT-S ERROR	19°C Down	20°C Up	COMP. Operating TIME (ON / OFF)	20 / 30	15 / 35	22 / 28
RT-S TEMP	RT-S ERROR	19°C Down	20°C Up							
COMP. Operating TIME (ON / OFF)	20 / 30	15 / 35	22 / 28							
10.	SHORT CIRCUIT TEST	<p>1) START : by pressing REF.TEMP. CONTROL button 30 times continuously.</p> <p>2) CANCEL : by pressing TEMP CONTROL button 30 times continuously.</p> <p style="text-align: center;">Cf. the system generally operates after the limit time 60 hrs. passes.</p> <p>3) DISPLAY : LED lamps are SUPER, MIDDLE, VAC on</p> <p>4) CONTROL : COMP & FAN will be on independent of the operating condition.</p> <p style="text-align: center;">(There is no defrost mode on this test.)</p>								
11.	FUNCTION OF TIME REDUCTION	<p>1) HOW TO REDUCE: (There is no FASTKEY on PCB for MP.)</p> <ul style="list-style-type: none"> 1 min : Click FAST KEY one time 30 min : If you press FAST KEY continuously, you can reduce 30 minutes on each second. <p>2) Practical Use : Can be applied to reduce needless time on test.</p> <p style="text-align: center;">EX) function of stop for 6 min</p>								

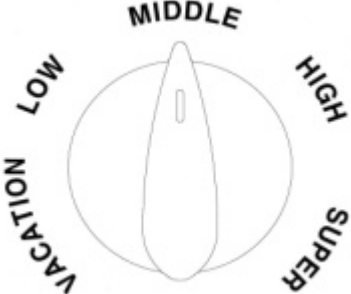
12.	POWER ON / OFF	<p>1) START : Press POWER button</p> <p>2) CANCELATION : Press POWER button again</p> <p>3) DISPLAY</p> <ul style="list-style-type: none"> - START : All LED lamps are off and power is off.(COMP, Heater, Lamp of Room) - CANCEL : Return to the last condition(dial)
13.	MEMORY SAVING ON POWER FAILURE	<p>-After power failure or momentary power failure happens, if power is back on, the mode will be returned on last condition.</p>
14.	EEPROM CLEAR	<p>-Make EEPROM clear right before shipping (set the initial mode)</p> <p>-How to clear : press REF.TEMP. button 5 time with pressing POWER button.</p>
15.	FUNCTION OF LOW ROOM TEMPERATURE	<p>1) Condition of LOW RT TEMP :</p> <p>1.1- LOW RT A : RT SENSOR < 14°C</p> <p>1.2- LOW RT B : 15°C > RT-S < 19°C</p> <p>2) Control</p> <p>2.1- When Comp. is on, R-SENSOR HTR is off.</p> <p>When it passes 6 min after COMP. is off, R-SENSOR HTR is on until COMP is on.</p> <p>2.2- COMP. Can't be on within 40 min. after COMP. is off.</p> <p>2.3- When it is not the Mode of LOW ROOM TEMP. or RT-SENSOR is on ERROR(open or short), R-SENSOR HTR is off.</p> <ul style="list-style-type: none"> - LOW RT TEMP A Condition <ul style="list-style-type: none"> - R-SENSOR Operating Temperature 1°C up - LOW RT TEMP B Condition <ul style="list-style-type: none"> R-SENSOR Operating Temperature

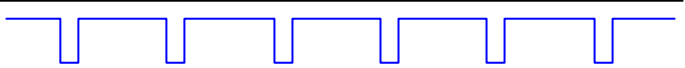
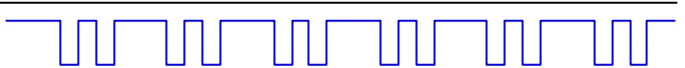
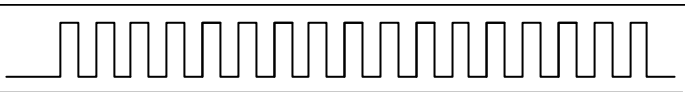
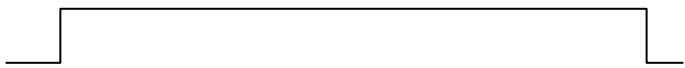
16.	R-SENSOR OFF POINT ADJUSTING OPTION	<p>1) R-SENSOR OFF POINT can be adjusted by changing the input voltage of MICOM 26 pin.</p> <p>2) The default of input voltage is 0V.</p> <p>3) The changed OFF POINT is base OFF POINT + OFF POINT of input voltage.</p>  <p>4) The change of R-SENSOR OFF POINT depend on the input voltage of MICOM</p> <table border="1" data-bbox="446 851 1500 1344"> <thead> <tr> <th>MICOM Input (V)</th> <th>0</th> <th>1.0</th> <th>1.5</th> <th>2.0</th> <th>2.5</th> <th>3.7</th> <th>5.0</th> </tr> </thead> <tbody> <tr> <td>OFF POINT Variation (°C)</td> <td>-0.5°C (DEF)</td> <td>1.0°C down</td> <td>2.0°C down</td> <td>3.0°C down</td> <td>1.0°C up</td> <td>2.0°C up</td> <td>3.0°C up</td> </tr> <tr> <td>R26, R27 Resistance (kOhms)</td> <td>Jumper adoption</td> <td>R27 : 40 R26 : 10</td> <td>R27:23.3 R26:10</td> <td>R27:15 R26:10</td> <td>R27:10 R26:10</td> <td>R27:3.5 R26:10</td> <td>R27:10 R26:DEL</td> </tr> </tbody> </table>	MICOM Input (V)	0	1.0	1.5	2.0	2.5	3.7	5.0	OFF POINT Variation (°C)	-0.5°C (DEF)	1.0°C down	2.0°C down	3.0°C down	1.0°C up	2.0°C up	3.0°C up	R26, R27 Resistance (kOhms)	Jumper adoption	R27 : 40 R26 : 10	R27:23.3 R26:10	R27:15 R26:10	R27:10 R26:10	R27:3.5 R26:10	R27:10 R26:DEL
MICOM Input (V)	0	1.0	1.5	2.0	2.5	3.7	5.0																			
OFF POINT Variation (°C)	-0.5°C (DEF)	1.0°C down	2.0°C down	3.0°C down	1.0°C up	2.0°C up	3.0°C up																			
R26, R27 Resistance (kOhms)	Jumper adoption	R27 : 40 R26 : 10	R27:23.3 R26:10	R27:15 R26:10	R27:10 R26:10	R27:3.5 R26:10	R27:10 R26:DEL																			
	LOW COOLING OPTION	<p>5) APPLICATION (MAIN PCB)</p> <p>5.1- GENERAL: MICOM 26 port - 0V</p> <p>5.2- DELETE J2 (CHANGING R OFF POINT 1DEG UP) : MICOM 26 port– 2.5V</p> <p>- R-SENSOR OFF POINT ADJUSTMENT (1 DEG. DOWN)</p> <p>- J1 DELETION on LOW COOLING OPTION</p> <p>Default resistance (31.4 Kohms) + 1.5 kohms = 32.9 Kohms</p> <p>Operating on condition that R-SENSOR OFF point goes down 1°C.</p>																								

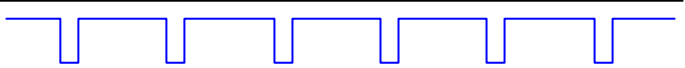
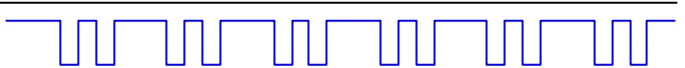
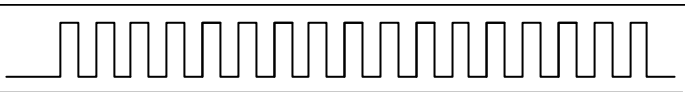
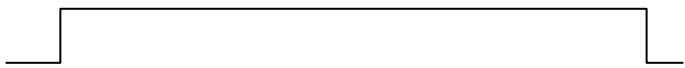
13.2. ERF-XXXN

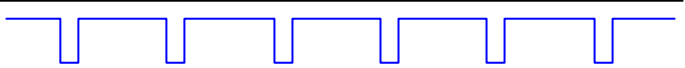
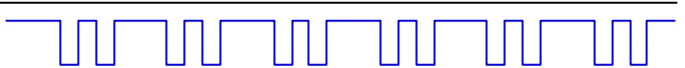
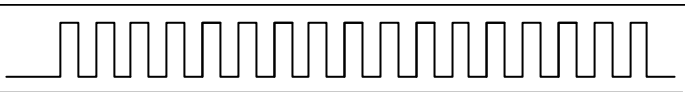
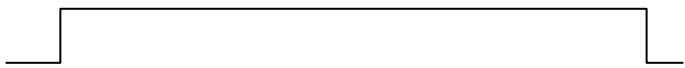
NO	FUNCTION	CONTENTS														
1.	DISPLAY	<div style="text-align: center;">  </div> <p>- Temperature control of Refrigerator</p> <p>Maximum angle clockwise : Temperature setting for SUPER</p> <p>Maximum angle counter-clockwise : Temperature setting for VACATION</p> <p>Maximum rotation : $280 \pm 10^\circ$</p> <p>Minimum Step Difference : $0.7 \text{ deg}/28^\circ$</p> <p>Total step Difference : 6.3 deg</p> <p>ERROR LED DISPLAY (ON MAIN PCB)</p> <table border="1" style="width: 100%; border-collapse: collapse;"> <thead> <tr> <th style="width: 50%;">DISPLAY</th> <th style="width: 50%;">LED</th> </tr> </thead> <tbody> <tr> <td>D1 ERROR</td> <td></td> </tr> <tr> <td>D2 ERROR</td> <td></td> </tr> <tr> <td>R1 ERROR</td> <td></td> </tr> <tr> <td>RT ERROR</td> <td></td> </tr> <tr> <td>EP ERROR</td> <td></td> </tr> <tr> <td>DR ERROR</td> <td></td> </tr> </tbody> </table> <p>? FUNCTION DISPLAY</p> <ul style="list-style-type: none"> - D1 ERROR : LED is off & on one time. - D2 ERROR : LED is off & on two times. - R1 ERROR : LED is on & off one time. - RT ERROR : LED is on & off two times. - DR ERROR : LED is on continually - Buzzer sounds if any button of M-PCB(SW2) is pushed. - FORCED DEFROST OF CONDITION : Button of MPCB(SW2) is pushed 1 time. - SHORT CIRCUIT OF CONDITION : Button of MPCB(SW2) is pushed 2 times. 	DISPLAY	LED	D1 ERROR		D2 ERROR		R1 ERROR		RT ERROR		EP ERROR		DR ERROR	
DISPLAY	LED															
D1 ERROR																
D2 ERROR																
R1 ERROR																
RT ERROR																
EP ERROR																
DR ERROR																

2.	TEMPERATURE ADJUSTMENT & CONTROL	<p>1) TEMPERATURE ADJUSTMENT</p> <p>1.1- TEMPERATURE ADJUSTMENT TEMP CONTROL DIAL is rotated VAC , LOW, MIDDLE, HIGH, SUPER. TEMPERATURE will be set if the Dial doesn't get rotated again within 5 sec</p> <p>1.2- FORCED DEFROST : Button of M-PCB(SW2) is pushed 1 time.</p> <p>1.3- SHORT CIRCUIT OPERATION : Button of MPCB(SW2) is pushed 2 times.</p> <p>2) TEMPERATURE CONTROL</p> <p>2.1- COMP will be controlled by the on/off point of R-Sensor at each mode.</p> <p>2.2- STEP DIFF of ROOM R : 1.4 deg</p> <p>2.3- Middle OFF point of ROOM R : -0.15°C</p> <p>2.4- ON/OFF DIFF of ROOM R : 3 deg</p> <p>3) FORCED DEFROST</p> <p>3.1- Defrost mode will be Started independent of the cycle.</p> <p>3.2- The flow is same as the general defrost mode flow.</p> <p>4) SHORT CIRCUIT OPERATION</p> <p>4.1- COMP & FAN will be on independent of the operation condition.</p> <p>4.2- The time limit of SHORT CIRCUIT OPERATION: 60 hrs</p>
3.	VACATION	<p>- Rotate TEMP. CONTROL Dial and make Vacation Location.</p> <p>ON POINT: 5.65°C</p> <p>OFF POINT: 2.65°C</p>

4.	SUPER	<p>- Rotate TEMP. CONTROL Dial and make Super Location ON POINT: 0.05°C OFF POINT: -2.95°C</p>																													
5.	DETERMINATION OF DEFROST	<p>- Starting condition of Defrost Mode</p> <ul style="list-style-type: none"> - When accumulated running time of comp. is 8, 10, 12, 18, 30hrs. - After Checking the condition '2.1' if total time(COMP on time + COMP off time) is more than 24, 48, 36, 72hrs, then defrost mode starts immediately. <table border="1" style="width: 100%; border-collapse: collapse; text-align: center;"> <thead> <tr> <th rowspan="2">RT-SENSOR</th> <th colspan="2">Accumulated running time of COMP</th> <th colspan="2">Total running time of COMP</th> </tr> <tr> <th>Door Open</th> <th>Door Close</th> <th>Door Open</th> <th>Door Close</th> </tr> </thead> <tbody> <tr> <td>RT 29°C Up</td> <td>8HR</td> <td>18HR</td> <td>24HR</td> <td>36HR</td> </tr> <tr> <td>20<RT< 28°C</td> <td>12HR</td> <td>30HR</td> <td>48HR</td> <td>72HR</td> </tr> <tr> <td>15<RT< 19°C</td> <td>8HR</td> <td>12HR</td> <td>24HR</td> <td>36HR</td> </tr> <tr> <td>RT 14°C Down</td> <td>8HR</td> <td>10HR</td> <td>24HR</td> <td>36HR</td> </tr> </tbody> </table>	RT-SENSOR	Accumulated running time of COMP		Total running time of COMP		Door Open	Door Close	Door Open	Door Close	RT 29°C Up	8HR	18HR	24HR	36HR	20<RT< 28°C	12HR	30HR	48HR	72HR	15<RT< 19°C	8HR	12HR	24HR	36HR	RT 14°C Down	8HR	10HR	24HR	36HR
RT-SENSOR	Accumulated running time of COMP			Total running time of COMP																											
	Door Open	Door Close	Door Open	Door Close																											
RT 29°C Up	8HR	18HR	24HR	36HR																											
20<RT< 28°C	12HR	30HR	48HR	72HR																											
15<RT< 19°C	8HR	12HR	24HR	36HR																											
RT 14°C Down	8HR	10HR	24HR	36HR																											
6.	DEFROST MODE	<p>1) General Defrost Mode</p> <ul style="list-style-type: none"> 1.1- Start : By determination of defrost 1.2- Process : General operation - Heater on - Pause (6min) - General operation -Heater defrost : When the temperature at D-sensor is over 10°C, heater turns off. -Limit time : 80 min (30 min on D sensor error) <p>2) Forced Defrost Mode</p> <ul style="list-style-type: none"> 2.1 Start : Button of M-PCB(SW2) is pushed 1 Time. 2.2 Process : same as General Defrost Mode -Heater is supposed to be on Initial 30 seconds. (for TEST) 																													
7.	INITIAL DEFROST	<p>1) When power is on, if the temperature at the D-sensor is under 3.5°C, then General Defrost Mode starts.</p> <p>2) When initial defrost mode starts, heater will be on directly and defrost mode will be started.</p>																													
8.	PREVENTION OF COMP. RESTART	<p>COMP. doesn't work after COMP. turns off even though Rsensor is on condition. (This is to protect comp.)</p> <ul style="list-style-type: none"> 1) General operation : The COMP can't be on within 6 min. 2) Operation of LOW RT : The COMP can't be on within 40 min. 																													

9.	ERROR DISPLAY & CONTROL	<p>* ERROR DISPLAY</p> <p>a. When error happens, it is displayed on led lamp.(Main PCB LED 1)</p> <p>1) R1 ERROR (It happens when R-SENSOR is OPEN or SHORT)</p> <p>1.1- DISPLAY : On & off one time while LED is on.</p> <p>1.2- CONTROL : Contrdled by the condition of RT</p> <p style="text-align: right;">(Unit : min)</p> <table border="1" data-bbox="459 443 1497 555"> <tr> <td>RT-S TEMP</td> <td>RT-S ERROR</td> <td>19°C Down</td> <td>20°C Up</td> </tr> <tr> <td>COMP. Operating TIME (ON / OFF)</td> <td>20 / 30</td> <td>15 / 35</td> <td>22 / 28</td> </tr> </table> <p>1.3- CANCEL : when R-SENSOR is working normally.</p> <p>2) D1 ERROR (It happens when D-SENSOR is OPEN or SHORT)</p> <p>2.1- DISPLAY : On & off one time while LED is off.</p> <p>2.2- CONTROL : Return to the limit defrost time of Defrost (30 min)</p> <p>3) D2 ERROR (It happens when heater is off by time ? 80 min).</p> <p>3.1- DISPLAY : On & off two times while LED is off.</p> <p>3.2- CONTROL : Return to next limit defrost time (80 min)</p> <p>4) RT ERROR (It happens when RTSENSOR is OPEN or SHORT)</p> <p>4.1- DISPLAY : On & off two times while LED is on.</p> <p>4.2- CONTROL : The system is normally operating but the controlling by RT-SENSOR doesn't work.</p> <p>4.3- CANCEL : when RT-SENSOR is working normally.</p> <p>5) DR ERROR</p> <p>5.1- Display : LED is on continuously</p> <p>5.2- Control : Deletion of function related door switch sensing</p> <p>5.3- If door switch(open & close) is sensed, the error is terminated automatically.</p>	RT-S TEMP	RT-S ERROR	19°C Down	20°C Up	COMP. Operating TIME (ON / OFF)	20 / 30	15 / 35	22 / 28
RT-S TEMP	RT-S ERROR	19°C Down	20°C Up							
COMP. Operating TIME (ON / OFF)	20 / 30	15 / 35	22 / 28							
10.	SHORT CIRCUIT TEST	<p>1) START : Button of M-PCB(SW2) is pushed 2 times and SW1 6 times.</p> <p>2) CANCEL : Button of M-PCB(SW2) is pushed 1 time.</p> <p>Cf. the system generally operates after the limit time 60 hrs. passes.</p> <p>3) CONTROL : COMP & FAN will be on independent of the operating condition.</p> <p>(There is no defrost mode on this test.)</p>								
11.	FUNCTION OF TIME REDUCTION	<p>1) HOW TO REDUCE: (There is no FAST KEY on PCB for MP.)</p> <p>1 min : Click FAST KEY on e time</p> <p>30 min : If you press FAST KEY continuously, you can reduce 30 minutes on each second.</p> <p>2) Practical Use : Can be applied to reduce needless time on test.</p> <p>EX) function of stop for 6 min</p>								

15. FUNCTION OF LOW ROOM TEMPERATURE

1) Condition of LOW RT TEMP :

1.1- LOW RT A : RT SENSOR <14°C

1.2- LOW RT B : 15°C > RT-S < 19°C

2) Control

2.1- When Comp. is on, R-SENSOR HTR is off.

When it passes 6 min after COMP. is off, R-SENSOR HTR is on until COMP is on.

2.2- COMP. can't be on within 40 min. after COMP. is off.

2.3- When it is not the Mode of LOW ROOM TEMP. or RT-SENSOR is on ERROR(open or short), R-SENSOR HTR is off.

- LOW RT TEMP A Condition

R-SENSOR Operating Temperature ↑C up

- LOW RT TEMP B Condition

R-SENSOR Operating Temperature

16. R-SENSOR OFF POINT ADJUSTING OPTION

1) R-Sensor OFF Point can be adjusted by changing the input voltage of Micom 26 pin.

2) The default of input voltage is 0V.

3) The changed OFF Point is base OFF POINT + OFF POINT of input voltage.

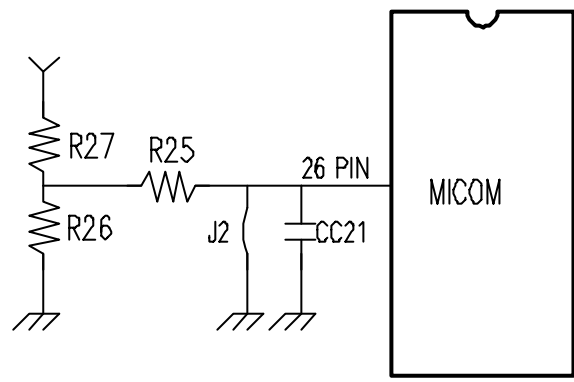

4) The change of RSENSOR OFF POINT depend on the input voltage of MICOM

MICOM Input (V)	0	1.0	1.5	2.0	2.5	3.7	5.0
OFF POINT Variation (°C)	-0.15°C (DEF)	1.0 Down	2.0 Down	3.0 Down	1.0 Up	2.0 Up	3.0 Up
R26, R27 Resistance (KOhms)	Jumper adoption	R27 : 40 R26 : 10	R27:23.3 R26:10	R27:15 R26:10	R27:10 R26:10	R27:3.5 R26:10	R27:10 R26:DEL

		<p>5) APPLICATION (MAIN PCB)</p> <p>5.1- GENERAL: MICOM 26 port - 0V</p> <p>5.2- DELETE J2 (CHANGING R OFF POINT 1DEG UP) : MICOM 26 port- 2.5V</p>
	<p>LOW COOLING OPTION</p>	<p>a. R-SENSOR OFF POINT ADJUSTMENT (1 DEG. DOWN)</p> <p>b. J1 DELETION on LOW COOLING OPTION</p> <p>Default resistance (31.4 KOhms) + 1.5 KOhms = 32.9 KOhms</p> <p>Operating on condition that R-SENSOR OFF point goes down 1°C.</p>



DAEWOO ELECTRONICS MANUFACTURING ESPAÑA S.A
Polígono industrial de Jándiz
C/Zurrupitieta 27, 01015 Vitoria, Spain

Tel: 00 34 945292292
Fax:00 34 945290965