

DAEWOO

# Service Manual

## Refrigerator

Model: FR-510M  
FR-540M  
FR-510P  
FR-540P

### ✓ Caution

: In this Manual, some parts can be changed for improving, their performance without notice in the parts list. So, if you need the latest parts information, please refer to PPL(Parts Price List) in Service Information Center (<http://svc.dwe.co.kr>).



1. Specification -----	1
2. External view-----	2
3. Wire diagram -----	3
4. Name of parts-----	4
5. Air flow diagram-----	5
6. Refrigerant cycle diagram -----	6
7. Machine room view and part list-----	7
8. Main components-----	8
9. Door color specification-----	9
10. Exploded view and parts list -----	15
11. Electronic function -----	25

# 1. SPECIFICATION

MODEL NAME		FR-510M	FR-540M	FR-510P	FR-540P
Refrigerant	R12	200g	200g	200g	200g
	R134a	170g	170g	170g	170g
Cooling System		Fan Cooling Convection			
Refrigeration System		Air Forced Convection			
Defrost System		Fin Evaporator Forced			
Defrost Operation		Automatic Start & Stop			
Cold Control		Adjustable Dial		Adjustable Button	
Capacity	Freezer	119 ℓ	118 ℓ	119 ℓ	118 ℓ
	Refrigerator	299 ℓ	306 ℓ	299 ℓ	306 ℓ
	Total	418 ℓ	424 ℓ	418 ℓ	424 ℓ
External Dimension	Height	1741mm	1768mm	1741mm	1768mm
	Width	770mm	770mm	770mm	770mm
	Depth	700mm	700mm	700mm	700mm
Net Weight		88Kg	89Kg	88Kg	89Kg

## 2. EXTERNAL VIEWS

### 1. FR-510M

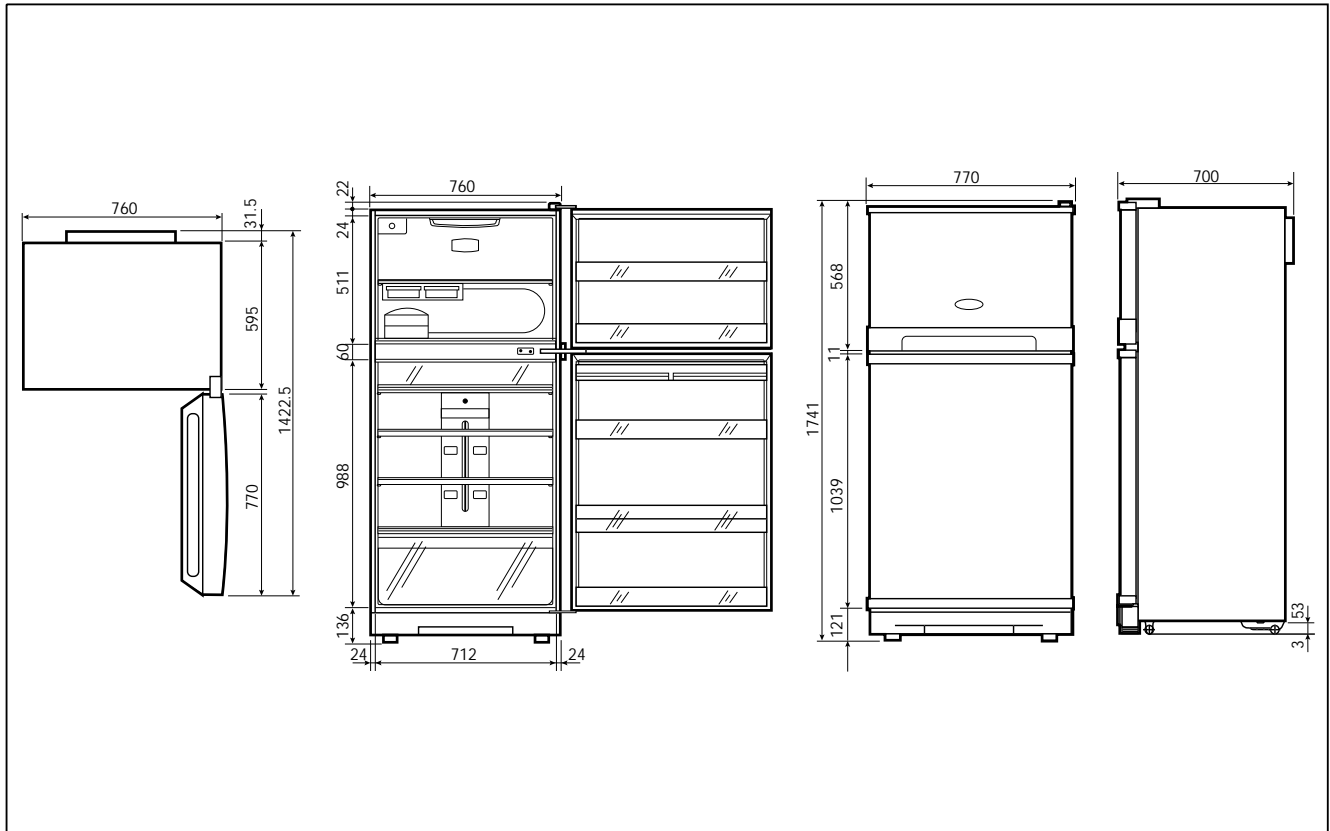

### 2. FR-540M

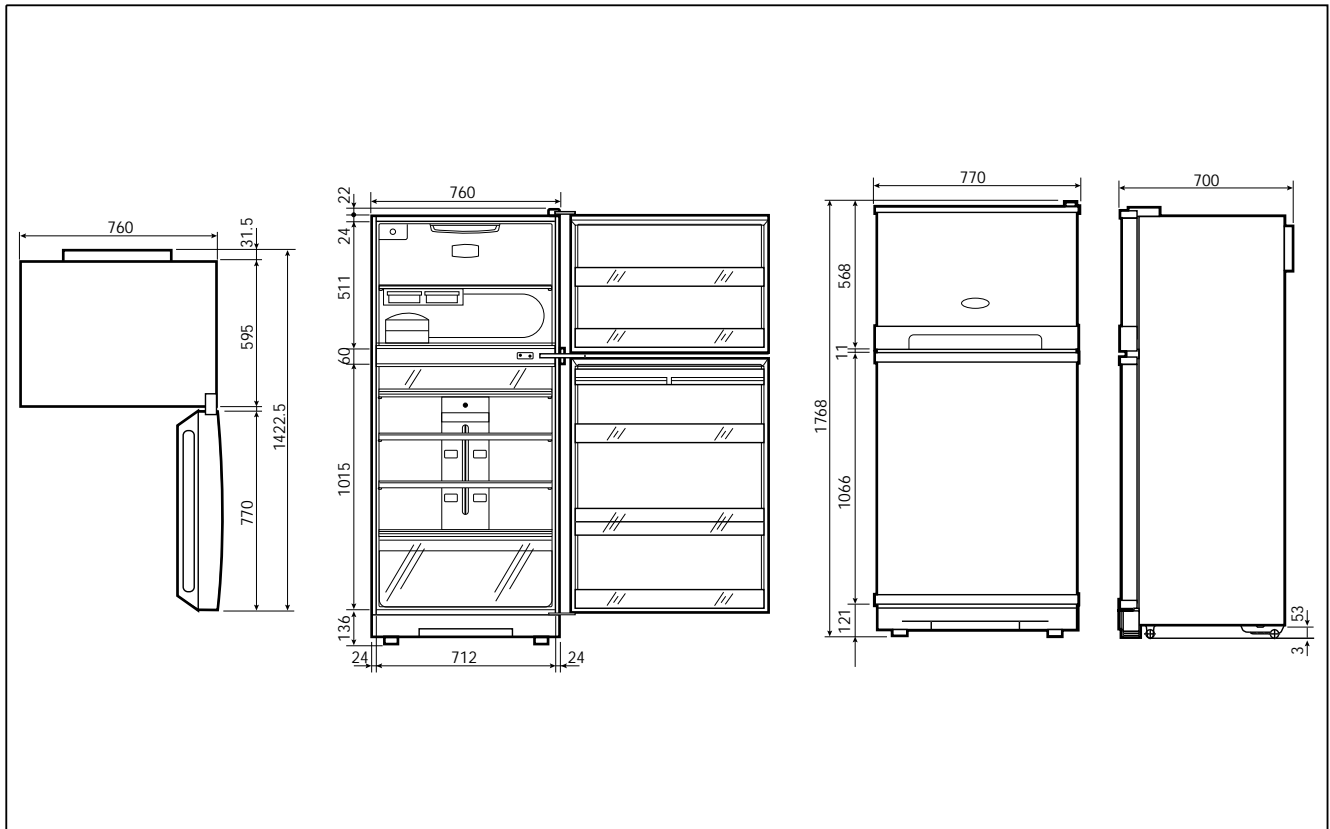

# 3. WIRE DIAGRAM

## 1. FR-510M, 540M

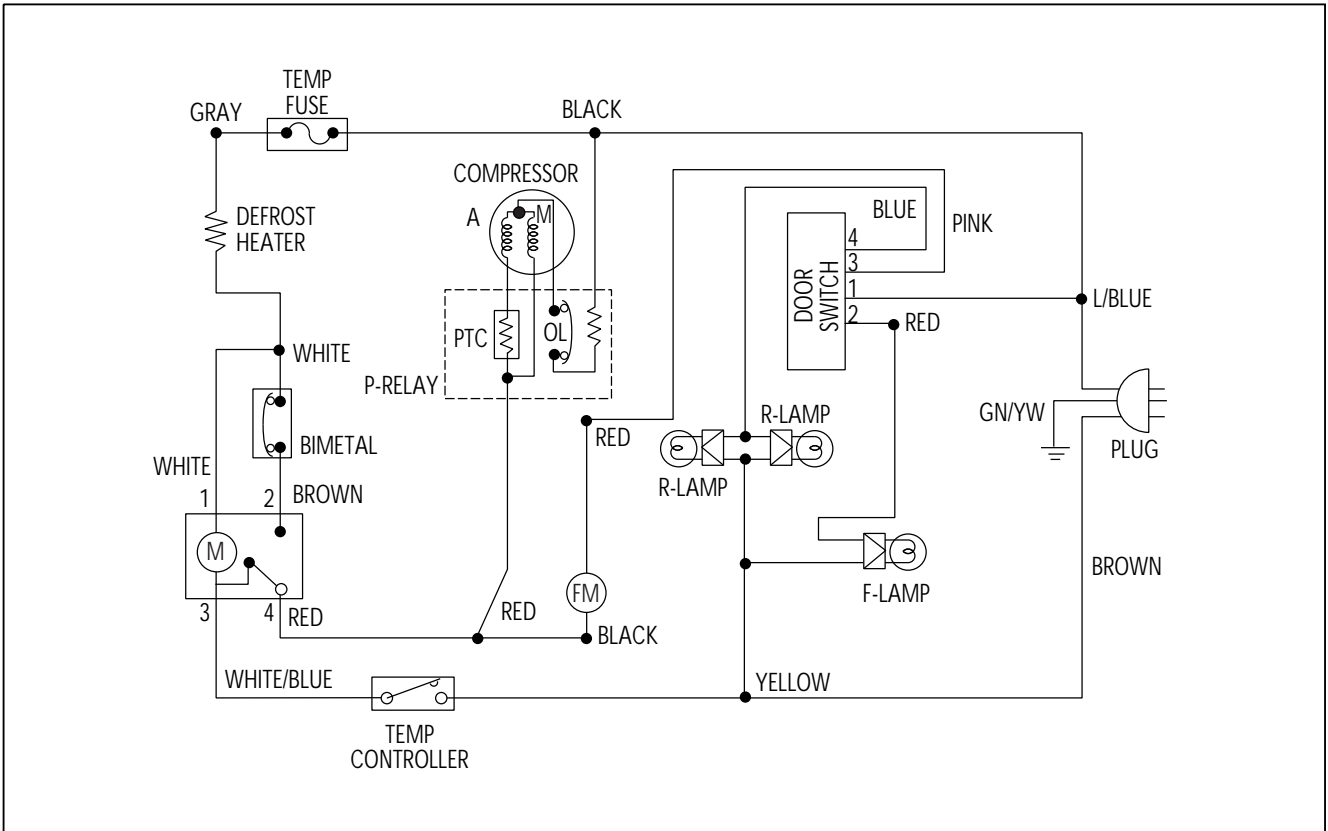

## 2. FR-510P, 540P

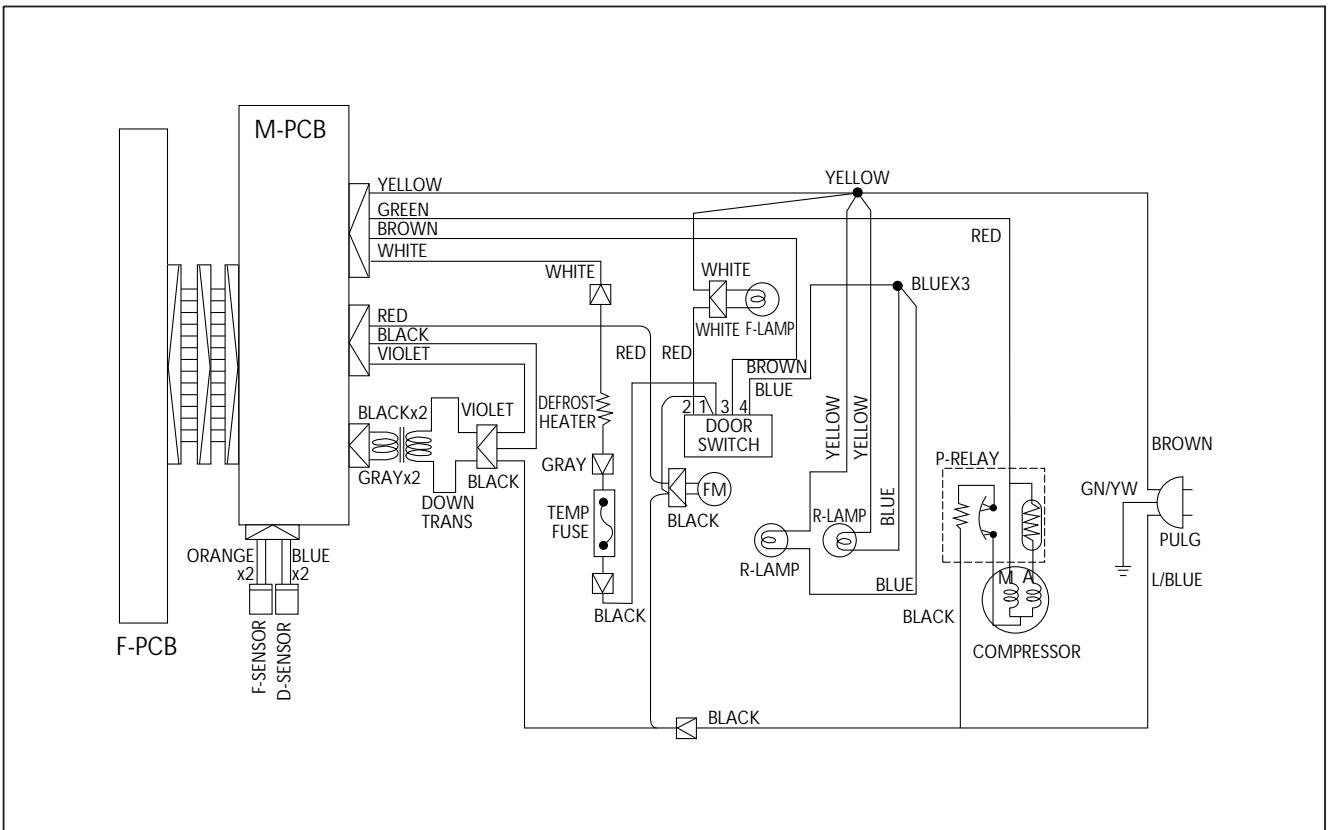

# 4. NAME OF PARTS

## 1. FR-510M, 540M

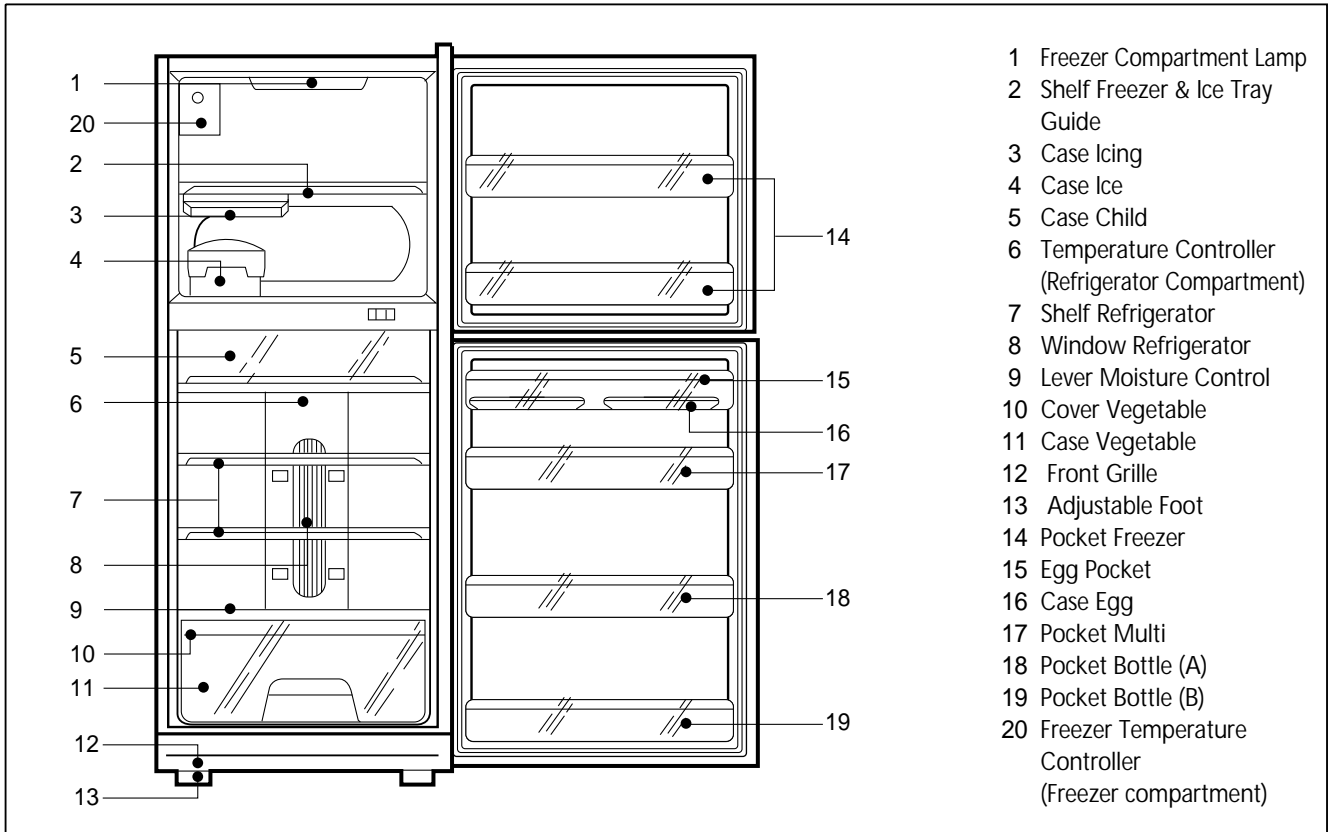

## 2. FR-510P, 540P

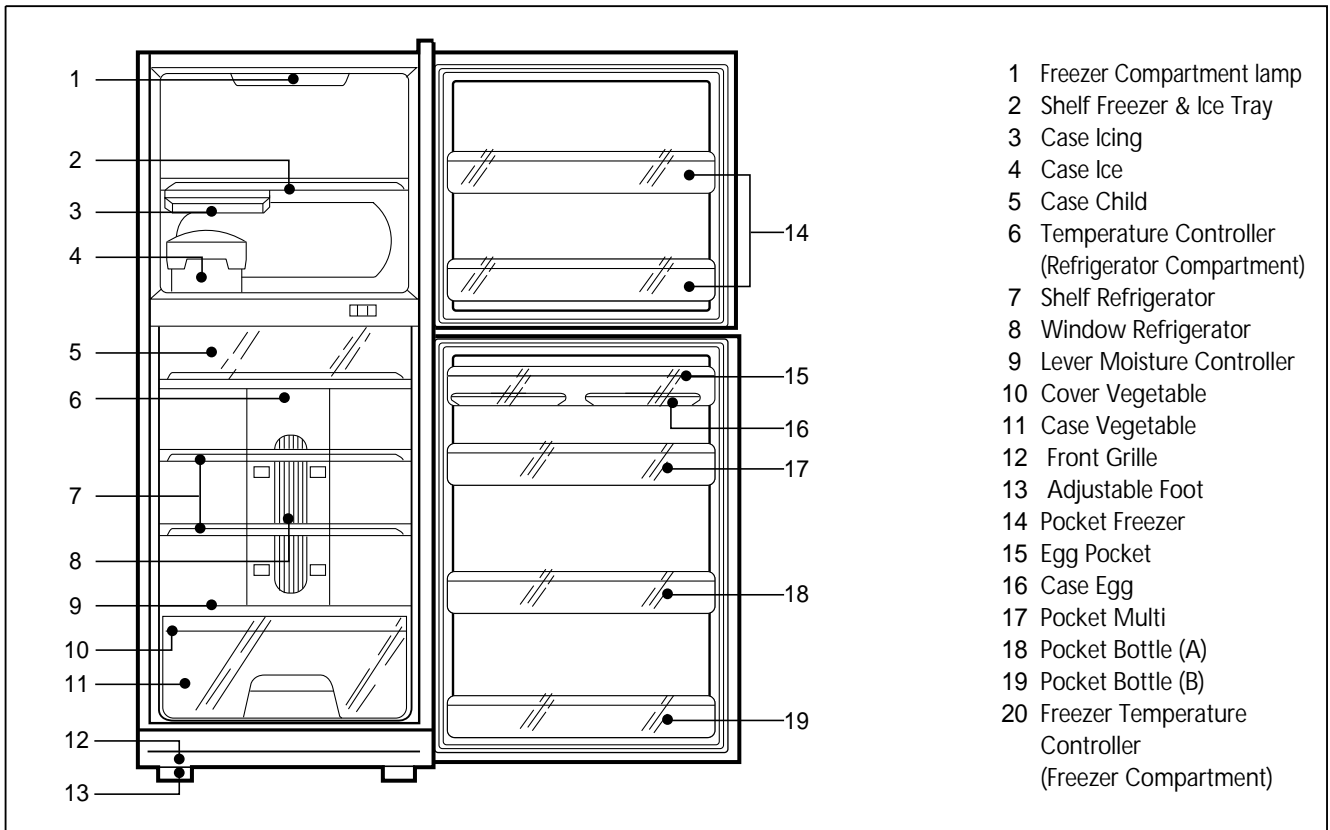

### 3. FR-510P

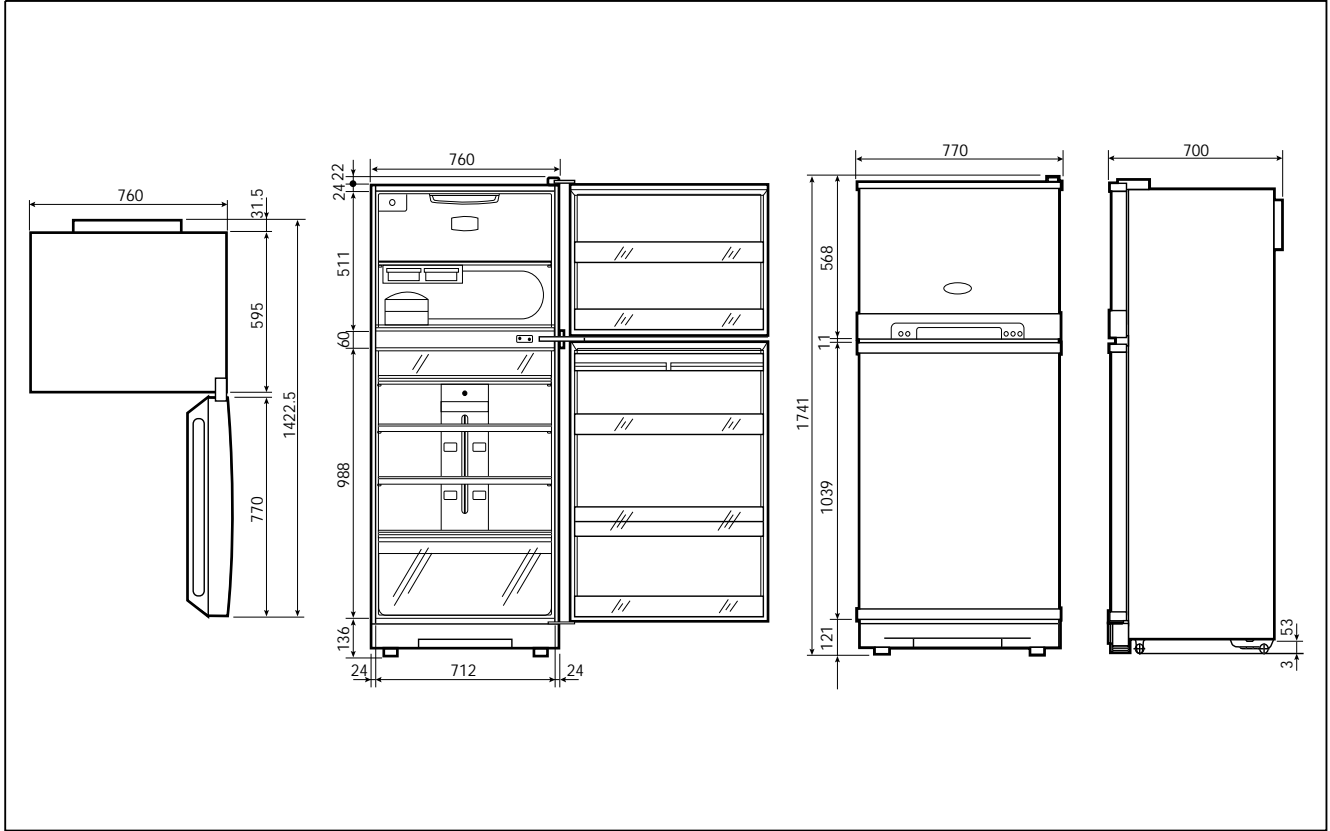

### 4. FR-540P

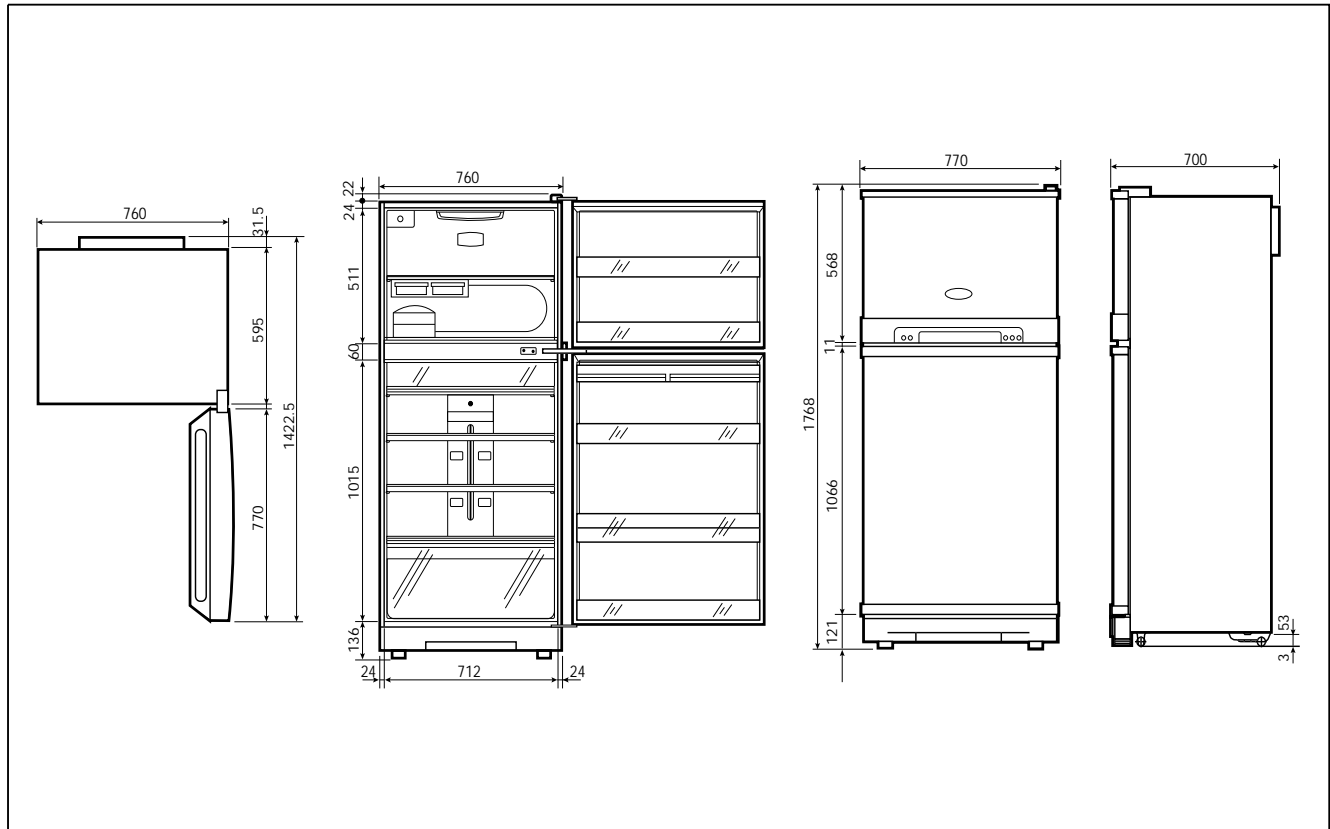

# 5. AIR FLOW DIAGRAM

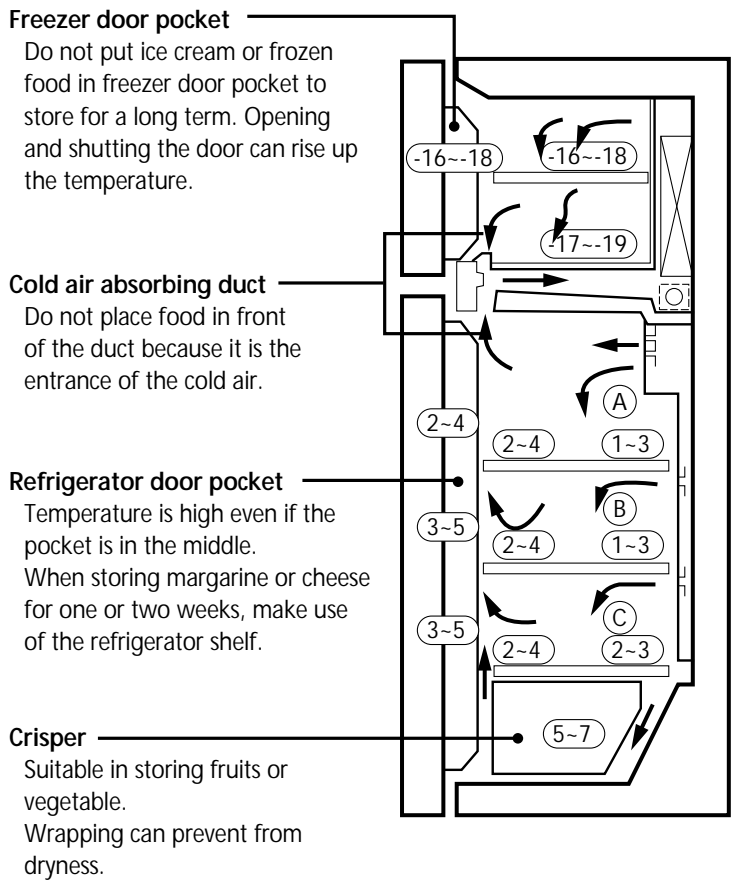

**Freezer door pocket**  
Do not put ice cream or frozen food in freezer door pocket to store for a long term. Opening and shutting the door can rise up the temperature.

**Cold air absorbing duct**  
Do not place food in front of the duct because it is the entrance of the cold air.

**Refrigerator door pocket**  
Temperature is high even if the pocket is in the middle. When storing margarine or cheese for one or two weeks, make use of the refrigerator shelf.

**Crisper**  
Suitable in storing fruits or vegetable. Wrapping can prevent from dryness.

**Freezer room**  
Do not put any bottle such as beer or beverage because it can be frozen and broken.

**Refrigerating room**  
This model is multi-flow type which flows out cold air from each shelf space. The hot air after making the refrigerator cold, flows into cooling system through the front upper part.

Do not put food having much moisture at the middle part of each shelf space ("A", "B" and "C" part). It can be frozen owing to the low temperature.



# 6. REFRIGERANT CYCLE DIAGRAM

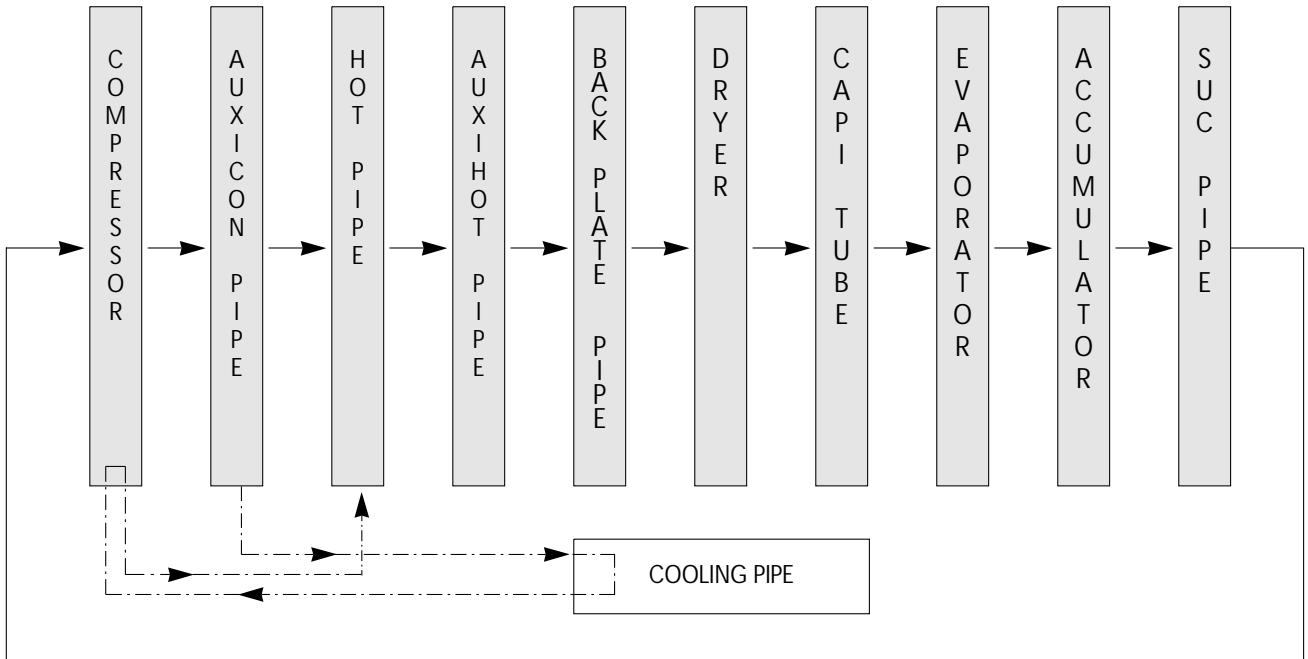
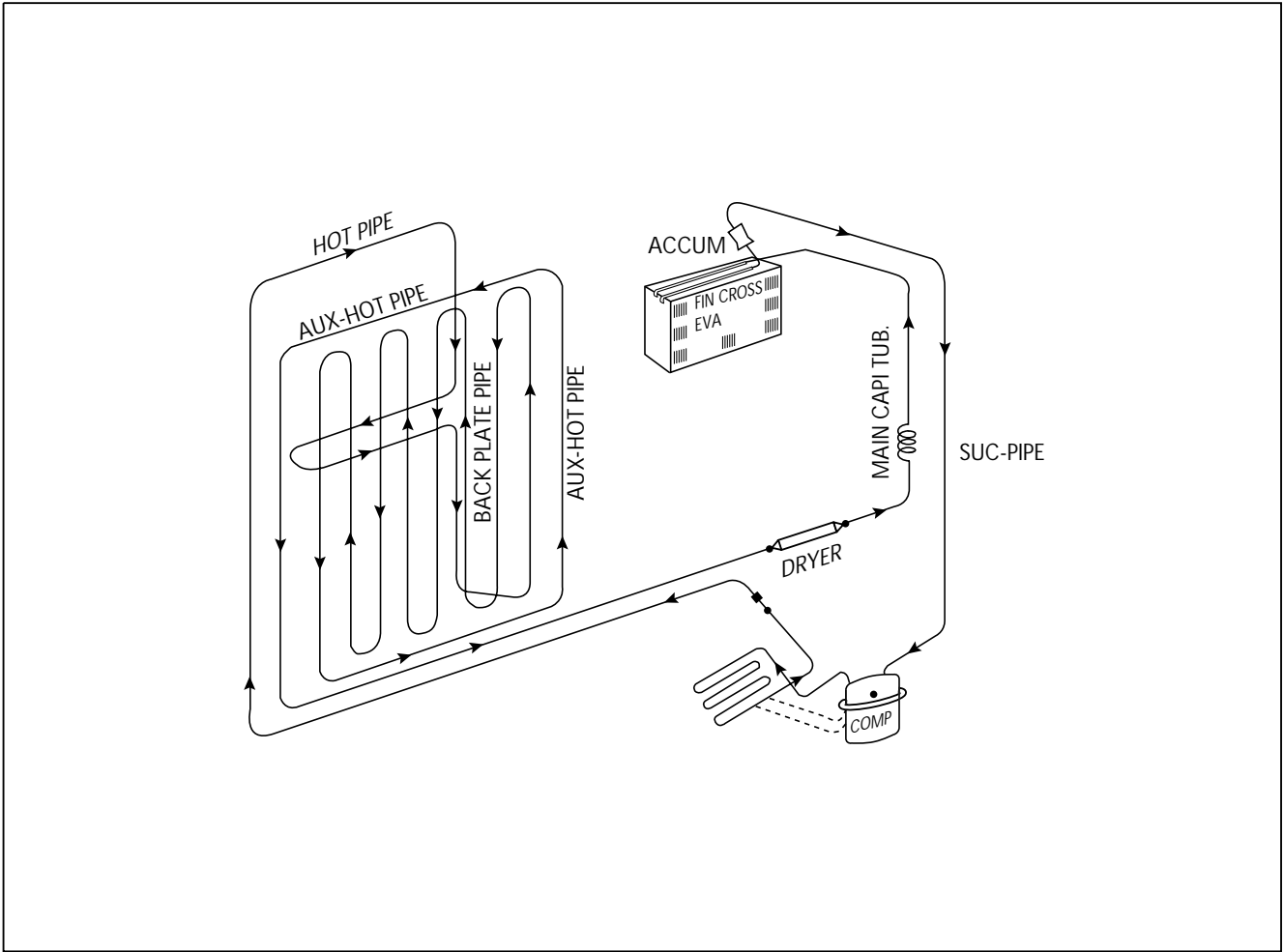

## 7. MACHINE ROOM VIEW AND PART LIST

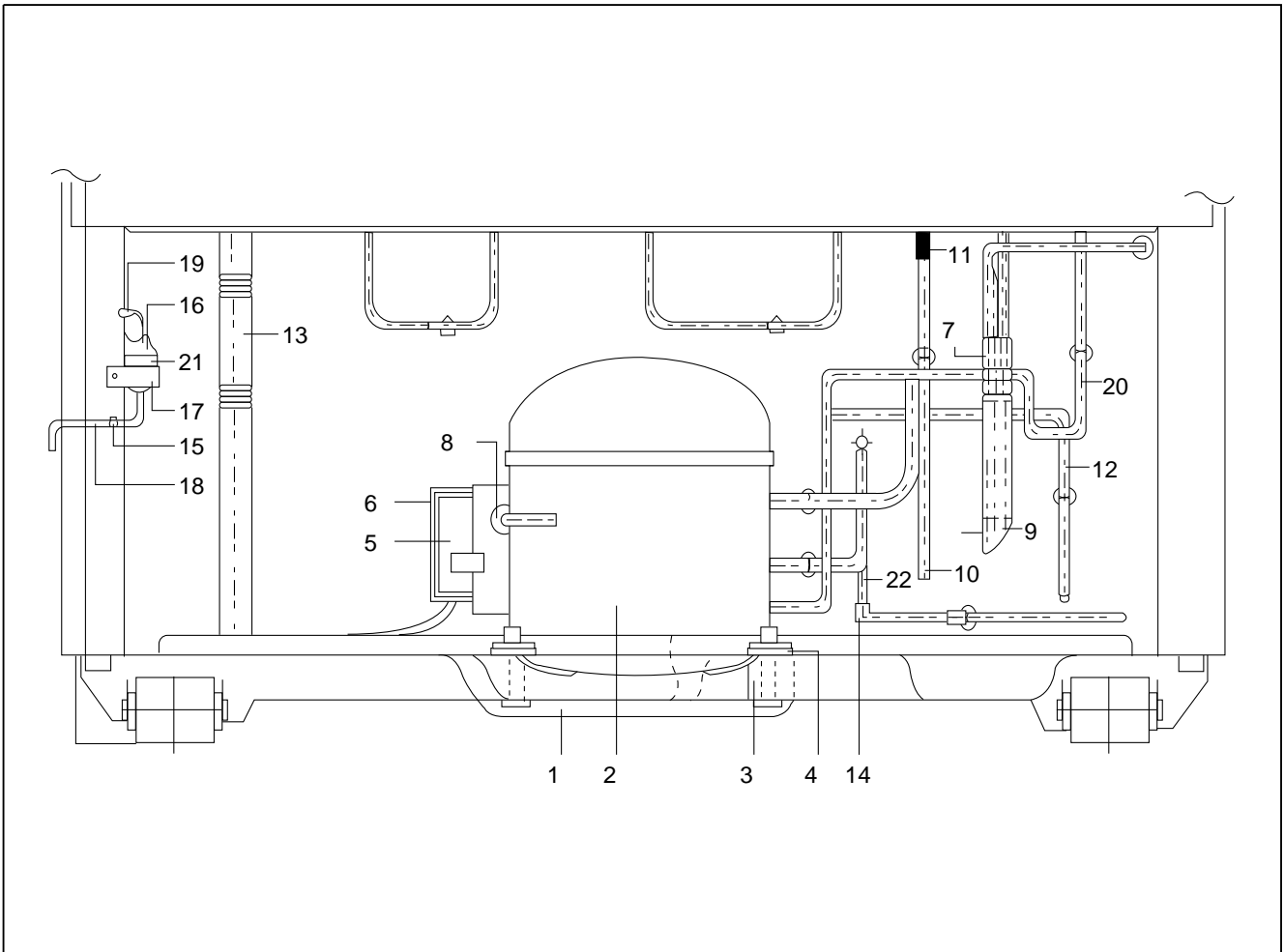

NO	PART NAME	NO	PART NAME	NO	PART NAME
1	BASE COMPRESSOR	9	DRYER	17	BIND WIRE
2	COMPRESSOR	10	PIPE CON (SUC)	18	PLUG POWER AS
3	ABSORBER COMPRESSOR	11	VIBRATIONPROOF GUM	19	SCREW MACHINE
4	WASHER COMP. *T	12	PIPE CON (AUX)	20	PIPE CON (HOT)
5	SWITCH P-RELAY AS	13	HOSE DRAIN (B)	21	TAPE OPP
6	BAND RELAY	14	VIBRATIONPROOF MASS	22	PIPE CON (P.A)
7	TAPE COTTON	15	SCREW TAPPING		
8	PIPE SERVICE	16	COVER CONNECTOR		

# 8. MAIN COMPONENTS

## 1. COMPRESSOR

Refrigerant	R12							
Voltage	100V/50,60Hz	110V/60Hz	115, 120V/60Hz	127V/60Hz	220V/50Hz	220V/60Hz	230V/50Hz	240V/50Hz
Comp. model	X	X	BL25YE-2-C	←	SL28YE-5-C	PL25YE-4-C	SL28YE-5-C	←
Part code	X	X	3952125C20	←	3954128C50	3956125C40	3954128C50	←
Strating type	X	X	CSR	←	RSIR	RSCR	RSIR	←

Refrigerant	R134a							
Voltage	100V/50,60Hz	110V/60Hz	115, 120V/60Hz	127V/60Hz	220V/50Hz	220V/60Hz	230V/50Hz	240V/50Hz
Comp. model	HBL25YE-C	HBL25YE-3-C	HBL25YE-2-C	←	HSL27YE-5-C	X	HSL27YE-5-C	←
Part code	3952125L00	3952125L30	3952125L20	←	3954127L50	X	3954127L50	←
Strating type	CSR	CSR	CSR	←	RSIR	X	RSIR	←

## 2. RELAY ASSEMBLY

Refrigerant	R12							
Voltage	100V/50,60Hz	110V/60Hz	115, 120V/60Hz	127V/60Hz	220V/50Hz	220V/60Hz	230V/50Hz	240V/50Hz
Relay model	X	X	317THBYY-52	←	276THBYY-52	197SHBYY-52	276THBYY-52	←
Part code	X	X	3018112000	←	3018105641	3018104102	3018105641	3018105641

Refrigerant	R134a							
Voltage	100V/50,60Hz	110V/60Hz	115, 120V/60Hz	127V/60Hz	220V/50Hz	220V/60Hz	230V/50Hz	240V/50Hz
Relay model	801RFBZZ-52	445RHBZZ-52	317THBYY-52	←	276THBYY-52	X	276THBYY-52	←
Part code	3018101630	3018101620	3018112000	←	3018105641	X	3018109901	3018105641

## 3. RUNNING CAPACITOR

Refrigerant	R12							
Voltage	100V/50,60Hz	110V/60Hz	115, 120V/60Hz	127V/60Hz	220V/50Hz	220V/60Hz	230V/50Hz	240V/50Hz
Spec.	X	X	300V/7 $\mu$ F	←	X	350V/5 $\mu$ F	X	X
Part code	X	X	3816800400	←	X	400EL15110	X	X

Refrigerant	R134a							
Voltage	100V/50,60Hz	110V/60Hz	115, 120V/60Hz	127V/60Hz	220V/50Hz	220V/60Hz	230V/50Hz	240V/50Hz
Spec.	200V/12 $\mu$ F	300V/7 $\mu$ F	←	←	X	X	X	X
Part code	3816801910	3816800400	←	←	X	X	X	X

## 4. STARTING CAPACITOR

Refrigerant	R12							
Voltage	100V/50,60Hz	110V/60Hz	115, 120V/60Hz	127V/60Hz	220V/50Hz	220V/60Hz	230V/50Hz	240V/50Hz
Spec.	X	X	200V/100 $\mu$ F	←	X	X	290V/50 $\mu$ F	X
Part code	X	X	401RD35050	←	X	X	4124G62020	X

Refrigerant	R134a							
Voltage	100V/50,60Hz	110V/60Hz	115, 120V/60Hz	127V/60Hz	220V/50Hz	220V/60Hz	230V/50Hz	240V/50Hz
Spec.	200V/100 $\mu$ F	←	←	←	X	X	290V/50 $\mu$ F	X
Part code	401RD35050	←	←	←	X	X	4124G62020	X

## 5. F-FAN MOTOR

Refrigerant	R12, R134a							
Voltage	100V/50,60Hz	110V/60Hz	115, 120V/60Hz	127V/60Hz	220V/50Hz	220V/60Hz	230V/50Hz	240V/50Hz
Spec.	3211DWBFBH	←	←	←	3211DWBFI	←	3211DWBFL	←
Part code	3011800660	←	←	←	3011800670	←	3011800640	←

## 6. DEFROST HEATER

Refrigerant	R12, R134a							
Voltage	100V/50,60Hz	110V/60Hz	115, 120V/60Hz	127V/60Hz	220V/50Hz	220V/60Hz	230V/50Hz	240V/50Hz
Spec.	148W	←	←	←	148W	←	←	←
Part code	3012801300	←	←	←	3012801000	←	←	←

## 7. LAMP ASSEMBLY

Refrigerant	R12, R134a							
Voltage	110V/50,60Hz	110V/60Hz	115, 120V/60Hz	127V/60Hz	220V/50Hz	220V/60Hz	230V/50Hz	240V/50Hz
Spec.	15W	←	←	←	15W	←	←	←
Part code	3013600050	←	←	←	3013600020	←	←	←

## 8. DEFROST TIMER (FR-510M, 540M)

Refrigerant	R12, R134a							
Voltage	100V/50,60Hz	110V/60Hz	115, 120V/60Hz	127V/60Hz	220V/50Hz	220V/60Hz	230V/50Hz	240V/50Hz
Spec.		←	←	←	TMDEX09UM1	←	←	←
Part code	3010513900	←	←	←	3018103920	←	←	←

## 9. PCB TRANSFORMER (FR-510P, 540P)

Refrigerant	R12, R134a							
Voltage	100V/50,60Hz	110V/60Hz	115, 120V/60Hz	127V/60Hz	220V/50Hz	220V/60Hz	230V/50Hz	240V/50Hz
Part code	5EPK057605	←	←	←	5EPK057604	←	5EPK057020	5EPK057608

## 10. MAIN PCB ASSEMBLY (FR-510P, 540P)

Refrigerant	R12, R134a							
Voltage	100V/50,60Hz	110V/60Hz	115, 120V/60Hz	127V/60Hz	220V/50Hz	220V/60Hz	230V/50Hz	240V/50Hz
Spec.	P707	←	←	←	←	←	←	←
Part code	3014304010	←	←	←	3014303810	←	←	←

## 11. DRYER

Refrigerant	R12	R134a
Spec.	10 g	15 g
Part code	3016800103	3016800910

## POWER CORD SPECIFICATION

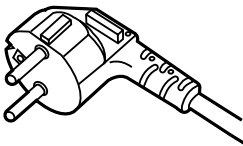
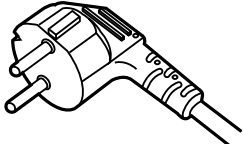
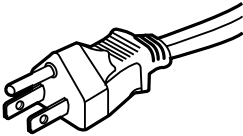
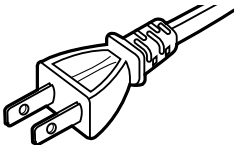
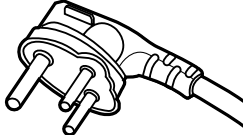
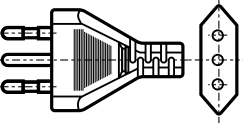
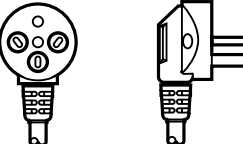
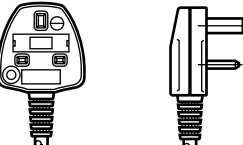
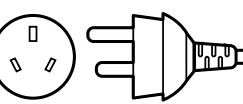
NO	SHAPE OF POWER CODE	PART CODE	DESCRIPTION	REMARK
1		3011315000	CP-2PIN	FOR EUROPEAN COUNTRY
2		401RA17200	CP-2PIN	FOR OTHER COUNTRY
3		4006D17101	KP-30	FOR AMERICA
4		401PD17101	KP-211	FOR JAPAN & TAIWAN
5		3011300801	BP-3PIN	
6		3011303010	#267	FOR CHILE
7		3011315310		FOR ISRAEL
8		3011303050	BS-1363A	FOR U.K, MIDDLE ASIA SINGAPORE & MALAYSIA
9		3011301200	KP-551/550	FOR CHINA & AUSTRALIA

\* Upper power cord's part code is only for lead wire, without any kinds of terminal or housing.

# 9. DOOR COLOR SPECIFICATION

## 1. FR-510M, 510P

### 1. ASSEMBLY URETHAN FREEZER DOOR

#### 1) FR-510M

Refrigerant	R12				R134a			
Color type	Dull lamina sheet	High glossy lamina sheet	Normal PCM	High glossy bright PCM	Dull lamina sheet	High glossy lamina sheet	Normal PCM	High glossy bright PCM
Part code	X	X	X	PFDT1UH110	X	X	X	PFDT1UH115

#### 2) FR-510P

Refrigerant	R12				R134a			
Color type	Dull lamina sheet	High glossy lamina sheet	Normal PCM	High glossy bright PCM	Dull lamina sheet	High glossy lamina sheet	Normal PCM	High glossy bright PCM
Part code	X	X	X	PFDT1UH030	X	X	X	PFDT1UH035

### 2. ASSEMBLY URETHAN REFRIGERATOR DOOR

Refrigerant	R12				R134a			
Color type	Dull lamina sheet	High glossy lamina sheet	Normal PCM	High glossy bright PCM	Dull lamina sheet	High glossy lamina sheet	Normal PCM	High glossy bright PCM
Part code	X	X	X	PFDU2UH030	X	X	X	PFDU2UH035

## 2. FR-540M, 540P

### 1. ASSEMBLY URETHAN FREEZER DOOR

#### 1) FR-540M

Refrigerant	R12				R134a			
Color type	Dull lamina sheet	High glossy lamina sheet	Normal PCM	High glossy bright PCM	Dull lamina sheet	High glossy lamina sheet	Normal PCM	High glossy bright PCM
Part code	X	X	X	PFDT1UJ130	X	X	X	PFDT1UJ135

#### 2) FR-540P

Refrigerant	R12				R134a			
Color type	Dull lamina sheet	High glossy lamina sheet	Normal PCM	High glossy bright PCM	Dull lamina sheet	High glossy lamina sheet	Normal PCM	High glossy bright PCM
Part code	X	X	X	PFDT1UJ030	X	X	X	PFDT1UJ035

### 2. ASSEMBLY URETHAN REFRIGERATOR DOOR

Refrigerant	R12				R134a			
Color type	Dull lamina sheet	High glossy lamina sheet	Normal PCM	High glossy bright PCM	Dull lamina sheet	High glossy lamina sheet	Normal PCM	High glossy bright PCM
Part code	X	X	X	PFDU2UJ030	X	X	X	PFDU2UJ035

## COLOR TABLE

### 1. PCM type

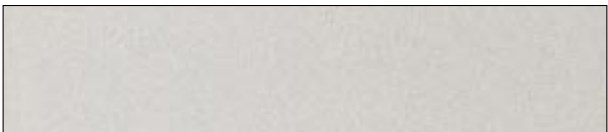
NO	COLOR CHIP	COLOR NAME
1		P/WITH (WH069)
2		'94 L/GRAY (GY158)
3		'95 L/GRAY (GY259)
4		'94 M/GRAY (GY331)
5		'95 M/GRAY (GY335)
6		'97 M/GRAY (GY267)
7		M. D/GRAY (GY750)
8		N/BLUE (BL718)
9		MINT GREEN (GN206)
10		'97 BEIGE (BE215)

## 2. Lamina sheet type

NO	COLOR CHIP	COLOR NAME
1		P/WITH (WH069)
2		'94 L/GRAY (GY158)
3		'95 L/GRAY (GY259)
4		'94 M/GRAY (GY331)
5		'95 M/GRAY (GY335)
6		'97 M/GRAY (GY267)
7		M. D/GRAY (GY750)
8		N/BLUE (BL718)
9		MINT GREEN (GN206)
10		S/GOLD
11		G/GREEN



# 10. EXPLODED VIEWS AND PARTS LIST

## 1. FR-510M, 540M

### 1.Exploded view

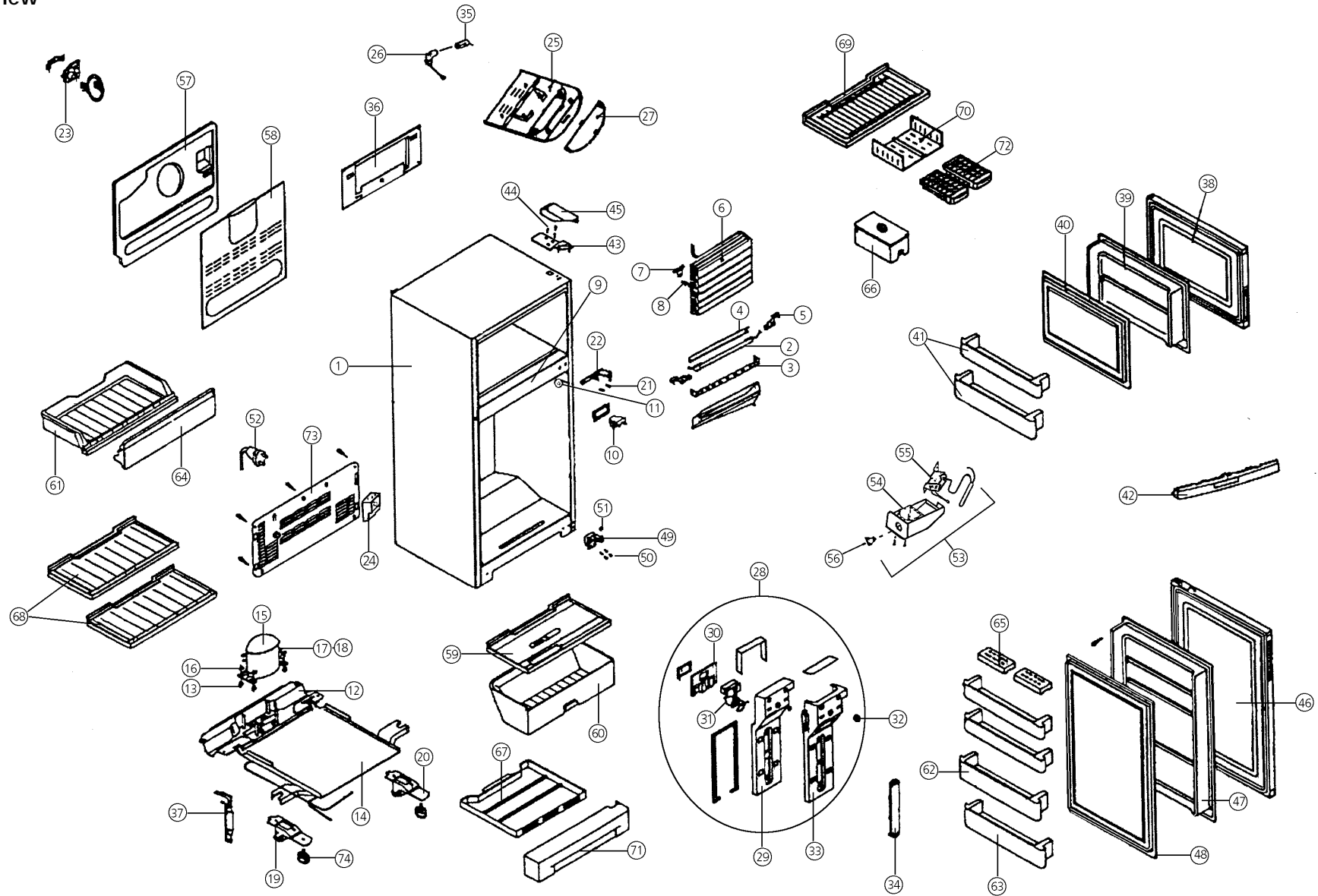

## 2. Parts list

NO	PART CODE	PART NAME	DESCRIPTION	QUANTITY	REMARK
1		ASSY URT CAB		1	
2		HEATER GLAS TUBE AS		1	REFER TO # 10
3	3011408100	COVER HTR *U		1	
4	3011408200	COVER HTR *T		1	
5	4010G19010	FIXTURE DEFR HTR		2	
6	3017000502	EVAPORATOR SAS		1	
7	400EL21213	FUSE TEMP AS		1	
8	3018111100	SWITCH BIMTL AS		1	
9	3014502101	PLATE DV AS		1	
10	3018100010	SWITCH DR	DSD-5	1	
11	4010G30351	FIXTURE DR CHILD		2	
12	3010302512	BASE COMP SAS		1	
13	3010100201	ABSORBER COMP	NR H=40	4	
14	3014502304	PLATE AXCON AS		1	
15		COMPRESSOR		1	REFER TO # 9
16	4019H09030	WASHER COMP *T	SK-5	4	
17		SWITCH P RELAY AS		1	REFER TO # 9
18	3816100100	RELAY BAND	SK-5 0.7T ZN-3-A	1	
19	3010604802	BRACKET ADJ FT *L AS		1	
20	3010604902	BRACKET ADJ FT *R AS		1	
21	3016000220	SPECIAL SCREW		2	
22	3012900620	HINGE *M AS	D/C	1	
23		MOTOR AS		1	REFER TO # 10
24	3018103920	SWITCH D TIMER AS	CHILE 350	1	
25	3011406600	COVER F M/F DUCT A	ABS	1	
26		LAMP AS		3	REFER TO # 10
27	3015500400	WINDOW F	G.E, PC-121R	1	
28	3010008910	ASSY M/F DUCT		1	
29	3013304901	INSULATOR M/F DUCT	F-PS	1	
30	4010G26030	INSULATOR DAMP B	F-PS	1	
31	4010G26401	R DAMPER AS	HF380	1	
32	4017G31152	KNOB DAMP	ABS	1	
33	3011408803	COVER M/F DUCT	HIPS	1	
34	3015500703	WINDOW R	GPPS	1	
35	3017900802	SOCKET F LAMP AS		1	
36	3011408400	COVER M/PCB BOX	PP	1	
37		DRYER AS		1	REFER TO # 10
38		ASSY URT *T DOOR		1	REFER TO # 12
39	3017402202	LINER F DR	ABS 1.4 x 785 x 1140	1	

NO	PART CODE	PART NAME	DESCRIPTION	QUANTITY	REMARK
40	3012300600	GASKET F DR AS	PVC-S	1	
41	3019002100	POCKET F *T	GPPS T3.0	2	
42	3014202610	PANEL F CONTL	ABS T2.3	1	
43	3012901400	HINGE *T AS		1	
44	3016001800	SPECIAL BOLT	M6 x L16	4	
45	3011408700	COVER *T HI	PP	1	
46		ASSY URT *U DOOR		1	REFER TO # 12
47	3017402301	LINER R DR	ABS 1.4 x 785 x 1060	1	
48	3012301600	GASKET R DR AS	PVC-S+MAGNET	1	
49	3012900401	HINGE *U AS	MF-ZN5-C	1	
50	3016000800	SPECIAL SCREW	T1 TRS 4 x 12 PW	4	
51	7400108511	WASHER PLAIN	PW-1.5T 8.5/20 MFZN	1	
52		CORD POWER AS		1	REFER TO # 11
53	3010501601	BOX CONTL AS		1	
54	3010500403	BOX CONTL	HIPS	1	
55	3018300401	THERMOSTAT		1	
56	4017G31041	KNOB C/S	ABS	1	
57	3013300022	INSULATOR F LUVR AS		1	
58	3018900900	LOUVER F M/F AS		1	
59	3011409010	COVER VEGETB BOOX AS	CV+F+KNOB+NAMP	1	
60	3010503720	CASE VEGTB	GPPS T 3.0	1	
61	3011102300	CASE CHILD	GPPS T 3.5	1	
62	3019002000	POCKET MULT	GPPS T 3.0	2	
63	3019002600	POCKET BOTL B	GPPS T 3.0	1	
64	3011705620	DOOR CHILD	GPPS	1	
65	3011103900	CASE EGG	GP	2	
66	4010E99102	BOX ICE AS		1	
67	4010G30661	BOILD	PP T1.3	1	
68	3017801920	SHELF R	GPPS	2	
69	3017804700	SHELF F		1	
70	3012500510	GUIDE ICING CASE	GPPS	1	
71	3011408501	COVER CAB BRKT	ABS	1	
72	3011102100	CASE ICING	PP	2	
73	3012400502	GRILLE	PP	1	
74	3010010900	ASSY ADJ FT PAKG		1	

NO	PART CODE	PART NAME	DESCRIPTION	QUANTITY	REMARK
1		ASSY URT CAB		1	
2		HEATER GLAS TUBE AS		1	REFER TO # 10
3	3011408100	COVER HTR *U	AL	1	
4	3011408200	COVER HTR *T	AL	1	
5	4010G19010	FIXTURE DEFR HTR		2	
6	3017000502	EVAPORATOR SAS		1	
7	400EL21213	FUSE TEMP AS		1	
8	3018111100	SWITCH BIMTL AS		1	
9	3014502101	PLATE DV AS		1	
10	3018100010	SWITCH DR		1	
11	4010G30351	FIXTURE DR CHILD		2	
12	3010302512	BASE COMP SAS		1	
13	3010100201	ABSORBER COMP	NR H=40	4	
14	3014502304	PLATE AXCON AS		1	
15		COMPRESSOR		1	REFER TO # 9
16	4019H09030	WASHER COMP *T	SK-5	4	
17		SWITCH P RELAY AS		1	REFER TO # 9
18	3816100100	RELAY BAND	SK-5 0.7T ZN-3-A	1	
19	3010604802	BRACKET ADJ FT *L AS		1	
20	3010604902	BRACKET ADJ FT *R AS		1	
21	3016000220	SPECIAL SCREW	M6 x 16 SWCH22A	2	
22	3012900620	HINGE *M AS	D/C	1	
23		MOTOR AS		1	REFER TO # 10
24	3018103920	SWITCH D TIMER AS	CHILE 350	1	
25	3011406600	COVER F M/F DUCT A	ABS	1	
26		LAMP AS		3	REFER TO # 10
27	3015500400	WINDOW F	G.E, PC-121R	1	
28	3010008910	ASSY M/F DUCT		1	
29	3013304901	INSULATOR M/F DUCT	F-PS	1	
30	4010G26030	INSULATOR DAMP B	F-PS	1	
31	4010G26401	R DAMPER AS	HF380	1	
32	4017G31152	KNOB DAMP	ABS	1	
33	3011408803	COVER M/F DUCT	HIPS	1	
34	3015500703	WINDOW R	GPPS	1	
35	3017900802	SOCKET F LAMP AS		1	
36	3011408400	COVER M/PCB BOX	PP	1	
37		DRYER AS		1	REFER TO # 10
38		ASSY URT *T DOOR		1	REFER TO # 12
39	3017402202	LINER F DR	ABS 1.4 x 785 x 1140	1	

NO	PART CODE	PART NAME	DESCRIPTION	QUANTITY	REMARK
40	3012300600	GASKET F DR AS	PVC-S	1	
41	3019002100	POCKET F *T	GPPS T3.0	2	
42	3014202610	PANEL F CONTL	ABS T2.3	1	
43	3012901400	HINGE *T AS		1	
44	3016001800	SPECIAL BOLT	M6 <sub>i</sub> d.16	4	
45	3011408700	COVER *T HI	PP	1	
46		ASSY URT *U DOOR		1	REFER TO # 12
47	3017402501	LINER R DR	ABS 1.4 x 785 x 1085	1	
48	3012300500	GASKET R DR AS	PVC-S	1	
49	3012900401	HINGE *U AS	MF-ZN5-C	1	
50	3016000800	SPECIAL SCREW	T1 TRS 4 x 12 PW	4	
51	7400108511	WASHER PLAIN	PW-1.5T 8.5/20 MFZN	1	
52		CORD POWER AS		1	REFER TO # 11
53	3010501601	BOX CONTL AS		1	
54	3010500403	BOX CONTL	HIPS	1	
55	3018300401	THERMOSTAT		1	
56	4017G31041	KNOB C/S	ABS	1	
57	3013300022	INSULATOR F LUVR AS		1	
58	3018900900	LOUVER F M/F AS		1	
59	3011409010	COVER VEGETB BOOX AS	CV+F+KNOB+NAMP	1	
60	3010503720	CASE VEGTB	GPPS T 3.0	1	
61	3011102300	CASE CHILD	GPPS T 3.5	1	
62	3019002000	POCKET MULT	GPPS T 3.0	2	
63	3019002600	POCKET BOTL B	GPPS T 3.0	1	
64	3011705620	DOOR CHILD	GPPS	1	
65	3011103900	CASE EGG	GP	2	
66	4010E99102	BOX ICE AS	SAN+ABS	1	
67	4010G30661	BOILD	PP T1.3	1	
68	3017801920	SHELF R	GPPS	2	
69	3017804700	SHELF F	GPPS	1	
70	3012500510	GUIDE ICING CASE	GPPS	1	
71	3011408501	COVER CAB BRKT	ABS	1	
72	3011102100	CASE ICING	PP	2	
73	3012400502	GRILLE	PP	1	
74	3010010900	ASSY ADJ FT PAKG		1	

2. FR-510P, 540P  
1. Exploded view

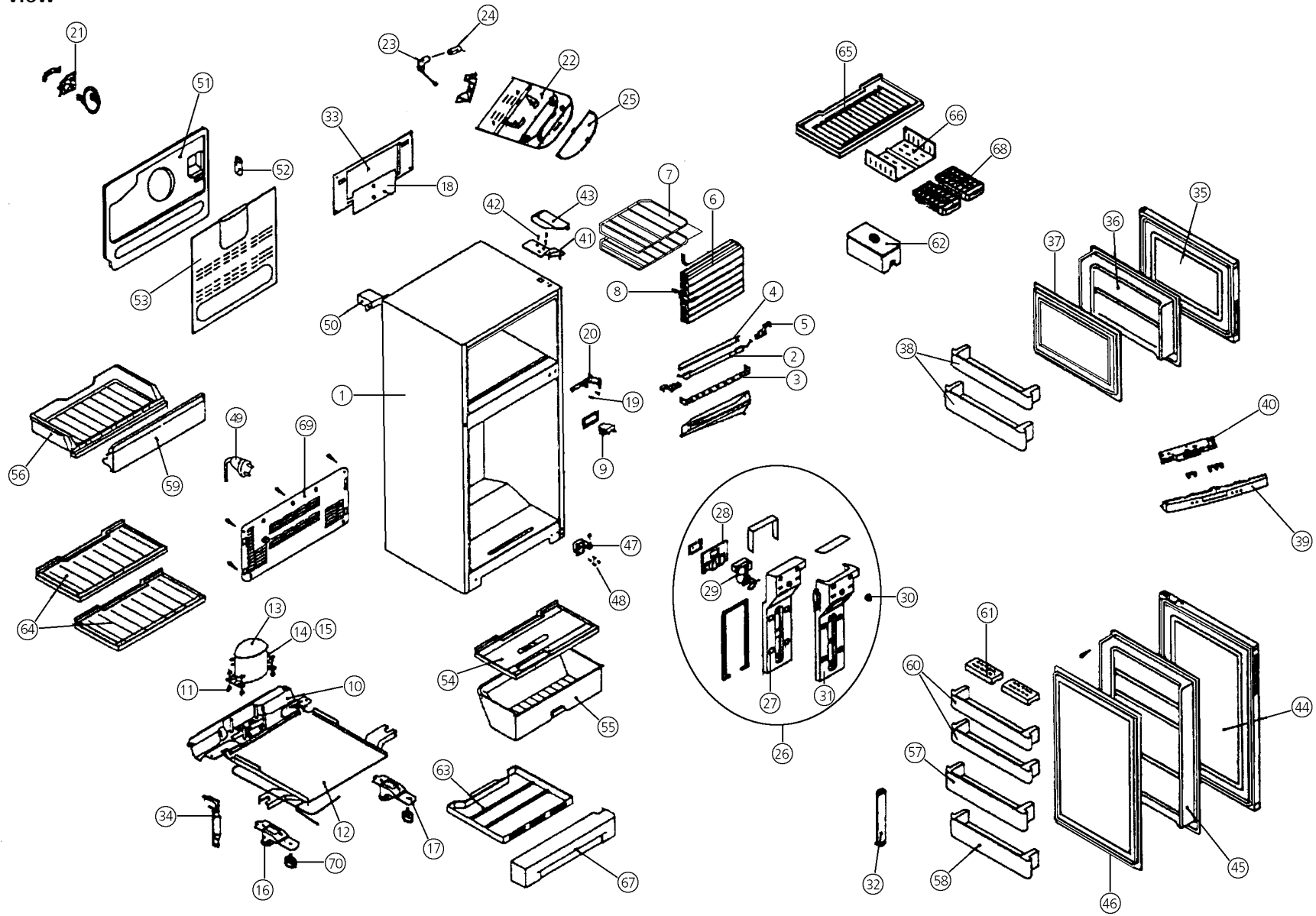

## 2. Parts list

✓ **Caution** : In this Service Manual, some parts can be changed for improving, their performance without notice in the parts list. So, if you need the latest parts information, please refer to PPL (Parts Price List) in Service Information Center (<http://svc.dwe.co.kr>)

NO	PART CODE	PART NAME	DESCRIPTION	QUANTITY	REMARK
1		ASSY URT CAB		1	
2		HEATER GLAS TUBE AS		1	REFER TO # 10
3	3011408100	COVER HTR *U	AL	1	
4	3011408200	COVER HTR *T	AL	1	
5	4010G19010	FIXTURE DEFR HTR		2	
6	3017000502	EVAPORATOR SAS		1	
7	400EL21213	FUSE TEMP AS		1	
8	400EL30151	SENSOR F-D AS		1	
9	3018100010	SWITCH DR	DSD-5	1	
10	3010302512	BASE COMP SAS		1	
11	3010100201	ABSORBER COMP	NR H=40	4	
12	3014502304	PLATE AXCON AS		1	
13		COMPRESSOR		1	REFER TO # 9
14		SWITCH P RELAY AS		1	REFER TO # 9
15	3816100100	RELAY BAND	SK-5 0.7T ZN-3-A	1	
16	3010604802	BRACKET ADJ FT *L AS		1	
17	3010604902	BRACKET ADJ FT *R AS		1	
18		PCB MAIN AS		1	REFER TO # 10
19	3016000220	SPECIAL SCREW	M6 x 16 SWCH22A	2	
20	3012900620	HINGE *M AS	D/C	1	
21		MOTOR AS		1	REFER TO # 10
22	3011406600	COVER F M/F DUCT A	ABS	1	
23	3017900802	SOCKET F LAMP AS		1	
24		LAMP AS		3	REFER TO # 10
25	3015500400	WINDOW F	G.E, PC-121R	1	
26	3010008910	ASSY M/F DUCT		1	
27	3013304901	INSULATOR M/F DUCT	F-PS	1	
28	4010G26030	INSULATOR DAMP B	F-PS	1	
29	4010G26401	R DAMPER AS	HF 380	1	
30	4017G31152	KNOB DAMP	ABS	1	
31	3011408803	COVER M/F DUCT	HIPS	1	
32	3015500703	WINDOW R	GPPS	1	
33	3011410000	COVER M/PCB BOX AS		1	
34		DRYER AS		1	REFER TO # 10
35		ASSY URT *T DOOR		1	REFER TO # 12
36	3017402202	LINER F DR	ABS	1	
37	3012301500	GASKET F DR	PVC-S+MAGNET	1	
38	3019002100	POCKET F *T	GPPS T3.0	2	
39	3014201300	PANEL F CONTL	ABS	1	

NO	PART CODE	PART NAME	DESCRIPTION	QUANTITY	REMARK
40	3014302300	PCB *F AS		1	
41	3012901400	HINGE *T AS		1	
42	3016001800	SPECIAL BOLT	M6 x L16	4	
43	3011408700	COVER *T HI	PP	1	
44		ASSY URT *U DOOR		1	REFER TO # 12
45	3017402301	LINER R DR	ABS 1.4 x 785 x 1060	1	
46	3012301600	GASKET R DR AS	PVC-S+MAGNET	1	
47	3012900401	HINGE *U AS	MF-ZN5-C	1	
48	3016000800	SPECIAL SCREW	T1 TRS 4 x 12 PW	4	
49		CORD POWER AS		1	REFER TO # 11
50		POWER TRANS		1	REFER TO # 10
51	3013300022	INSULATOR F LUVR AS	B-4231M	1	
52	4017Z29010	BRACKET F SENS	SPCC	1	
53	3018900900	LOUVER F M/F AS		1	
54	3011409010	COVER VEGETB BOX AS	CV+F+KNOB+NAMP	1	
55	3010503720	CASE VEGTB	GPPS T3.0	1	
56	3011102300	CASE CHILD	GPPS T3.5	1	
57	3019002000	POCKET MULT	GPPS T3.0	1	
58	3019002600	POCKET BOTL B	GPPS T3.0	1	
59	3011705620	DOOR CHILD	GPPS	1	
60	3019004100	POCKET *A	GPPS	2	
61	3011103900	CASE EGG	GP	2	
62	4010E99102	BOX ICE AS	SAN+ABS	1	
63	4010G30661	BOILD	PP T1.3	1	
64	3017801920	SHELF R	GPPS	2	
65	3017804700	SHELF F	GPPS	1	
66	3012500510	GUIDE ICING CASE	GPPS	1	
67	3011408501	COVER CAB BRKT	ABS	1	
68	3011102100	CASE ICING	PP	2	
69	3012400502	GRILLE	PP	1	
70	3010010900	ASSY ADJ FT PAKG		1	



✓ **Caution** : In this Service Manual, some parts can be changed for improving, their performance without notice in the parts list.  
 So, if you need the latest parts information, please refer to PPL (Parts Price List) in Service Information Center  
 (<http://svc.dwe.co.kr>)

NO	PART CODE	PART NAME	DESCRIPTION	QUANTITY	REMARK
1		ASSY URT CAB		1	
2		HEATER GLAS TUBE AS		1	REFER TO # 10
3	3011408100	COVER HTR *U	AL	1	
4	3011408200	COVER HTR *T	AL	1	
5	4010G19010	FIXTURE DEFR HTR		2	
6	3017000502	EVAPORATOR SAS		1	
7	400EL21213	FUSE TEMP AS		1	
8	400EL30151	SENSOR F-D AS		1	
9	3018100010	SWITCH DR	DSD-5	1	
10	3010302512	BASE COMP SAS		1	
11	3010100201	ABSORBER COMP	NR H=40	4	
12	3014502304	PLATE AXCON AS		1	
13		COMPRESSOR		1	REFER TO # 9
14		SWITCH P RELAY AS		1	REFER TO # 9
15	3816100100	RELAY BAND	SK-5 0.7T ZN-3-A	1	
16	3010604802	BRACKET ADJ FT *L AS		1	
17	3010604902	BRACKET ADJ FT *R AS		1	
18		PCB MAIN AS		1	REFER TO # 10
19	3016000220	SPECIAL SCREW	M6 x 16 SWCH22A	2	
20	3012900620	HINGE *M AS	D/C	1	
21		MOTOR AS		1	REFER TO # 10
22	3011406600	COVER F M/F DUCT A	ABS	1	
23	3017900802	SOCKET F LAMP AS		1	
24		LAMP AS		3	REFER TO # 10
25	3015500400	WINDOW F	G.E, PC-121R	1	
26	3010008910	ASSY M/F DUCT		1	
27	3013304901	INSULATOR M/F DUCT	F-PS	1	
28	4010G26030	INSULATOR DAMP B	F-PS	1	
29	4010G26401	R DAMPER AS	HF380	1	
30	4017G31152	KNOB DAMP	ABS	1	
31	3011408803	COVER M/F DUCT	HIPS	1	
32	3015500703	WINDOW R	GPPS	1	
33	3011410000	COVER M/PCB BOX AS		1	
34		DRYER AS		1	REFER TO # 10
35		ASSY URT *T DOOR		1	REFER TO # 12
36	3017402202	LINER F DR	ABS 1.4 x 785 x 1140	1	
37	3012301500	GASKET F DR	PVC-S+MAGNET	1	
38	3019002100	POCKET F *T	GPPS T3.0	2	
39	3014201300	PANEL F CONTL	ABS	1	

NO	PART CODE	PART NAME	DESCRIPTION	QUANTITY	REMARK
40	3014302300	PCB *F AS		1	
41	3012901400	HINGE *T AS		1	
42	3016001800	SPECIAL BOLT	M6 x L16	4	
43	3011408700	COVER *T HI	PP	1	
44		ASSY URT *U DOOR		1	REFER TO # 12
45	3017402501	LINER R DR	ABS 1.4 x 785 x 1085	1	
46	3012300500	GASKET R DR AS	PVC-S	1	
47	3012900401	HINGE *U AS	MF-ZN5-C	1	
48	3016000800	SPECIAL SCREW	T1 TRS 4; 12 PW	4	
49		CORD POWER AS		1	REFER TO # 11
50		POWER TRANS		1	REFER TO # 10
51	3013300022	INSULATOR F LUVR AS		1	
52	4017Z29010	BRACKET F SENS	SPCC	1	
53	3018900900	LOUVER F M/F AS		1	
54	3011409010	COVER VEGETB BOOX AS	CV+F+KNOB+NAMP	1	
55	3010503720	CASE VEGTB	GPPS T3.0	1	
56	3011102300	CASE CHILD	GPPS T3.5	1	
57	3019002000	POCEKT MULT	GPPS T3.0	1	
58	3019002600	POCEKT BOLT B	GPPS T3.0	1	
59	3011705620	DOOR CHILD	GPPS	1	
60	3019004100	POCKET *A	GPPS	2	
61	3011103900	CASE EGG	GP	2	
62	4010E99102	BOX ICE AS	SAN+ABS	1	
63	4010G30661	BOILD	PP T1.3	1	
64	3017801920	SHELF R	GPPS	2	
65	3017804700	SHELF F	GPPS	1	
66	3012500510	GUIDE ICING CASE	GPPS	1	
67	3011408501	COVER CAB BRKT	ABS	1	
68	3011102100	CASE ICING	PP	2	
69	3012400502	GRILLE	PP	1	
70	3010010900	ASSY ADJ FT PAKG		1	

# 11. ELECTRONIC FUNCTION

## 1. FR-510P, 540P

### 1) How to use the panel

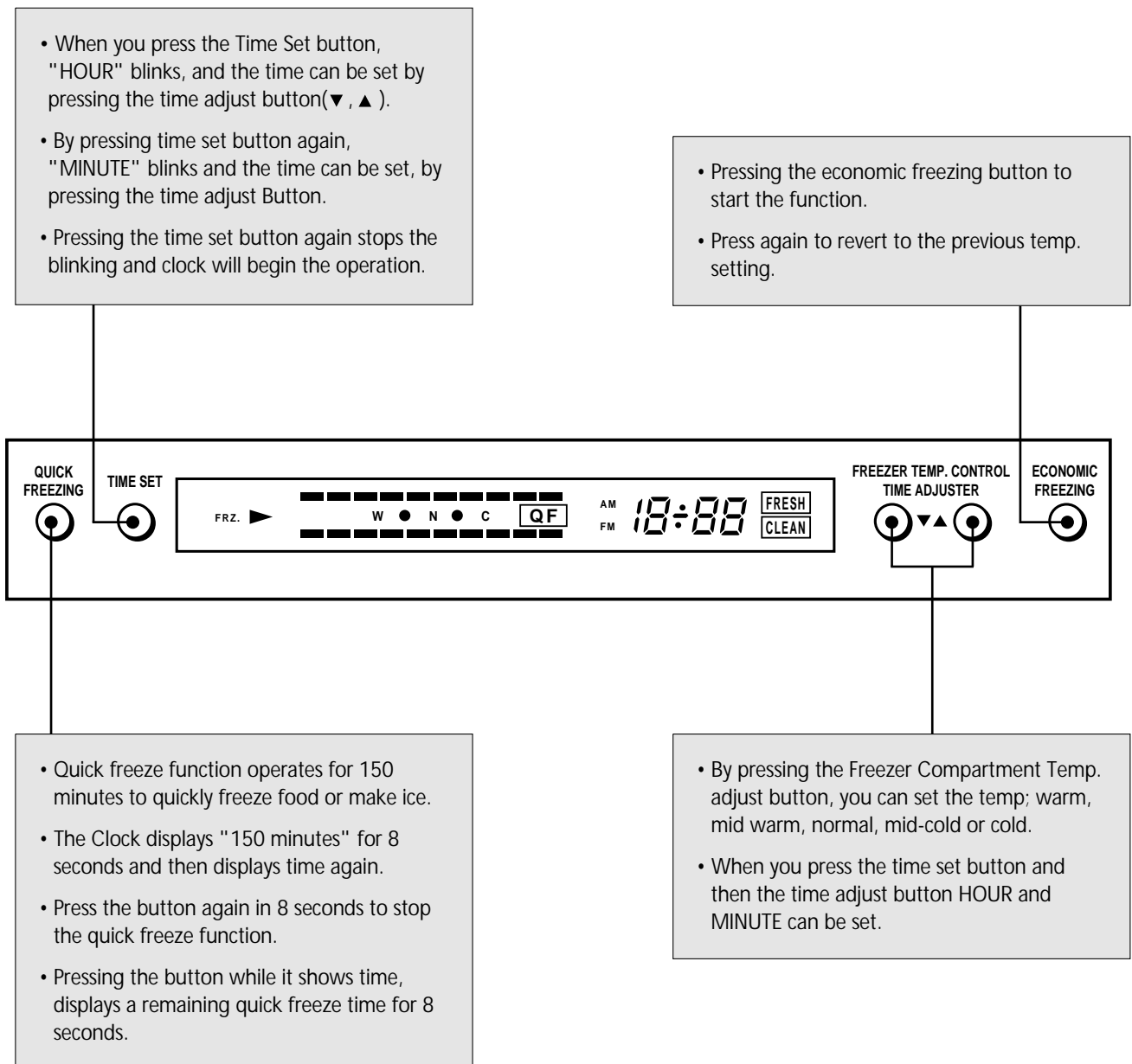

2) Function table

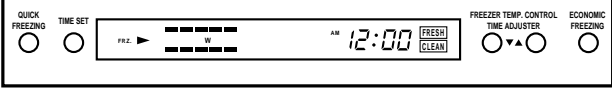
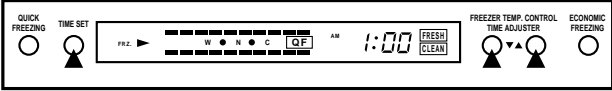
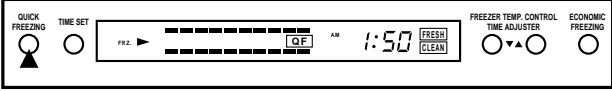
NO.	Control Function	Control Objects	Contents	Remark												
1	Initial operation	Time Temperature control	<p>1. In the initial operation, the temperature is automatically set at normal position and the clock is set at 12:00 AM.</p> 													
2	Clock function	LED	<p>1. The time is set at 12:00 AM in initial operation.                  2. Time setting (Setting time 1:05 AM)                  1) When the time set button is pressed, the hour(12) blinks in 5 sec. interval.                  2) Set hour with the time adjust button(▼, ▲).                  3) When press the time set button again, hour is set and minute(00) will blink.                  4) Set minute with the time adjust button(▼, ▲).                  5) If press the time set button again, time will be set.                  ♦ If do not set time in 5 seconds after pressing the time adjust button, the function will be canceled automatically.</p> 													
3	Quick freezing	COMP. F-fan C-fan LED	<p>1. When press the quick freezing button at 1:05 AM, quick freezing time of 150 min. will display for 8 sec., and then return to 1:05 AM.                  ♦ Pressing the button again in 8 sec. will cancel the function.</p>  <p>2. The bar LED lights 3 times every 30 min. in a row.                  ♦ The LED displays the irrelevant temperature.</p> <table border="1" data-bbox="635 1503 1281 1765"> <thead> <tr> <th>Quick Freeze is on</th> <th>After 30 minutes</th> <th>After an Hour</th> </tr> </thead> <tbody> <tr> <td>■ □ □</td> <td>■ ■ □</td> <td>■ ■ ■</td> </tr> <tr> <td>C Q.F</td> <td>C Q.F</td> <td>C Q.F</td> </tr> <tr> <td>■ □ □</td> <td>■ ■ □</td> <td>■ ■ ■</td> </tr> </tbody> </table> <p>3. The COMP. and F-fan is operated 150 min. jointly.                  4. If press the quick freezing button in quick freezing mode, the LED displays remaining time.</p>	Quick Freeze is on	After 30 minutes	After an Hour	■ □ □	■ ■ □	■ ■ ■	C Q.F	C Q.F	C Q.F	■ □ □	■ ■ □	■ ■ ■	
Quick Freeze is on	After 30 minutes	After an Hour														
■ □ □	■ ■ □	■ ■ ■														
C Q.F	C Q.F	C Q.F														
■ □ □	■ ■ □	■ ■ ■														
4	Freezer temperature control	COMP. F-fan C-fan LED	<p>1. The freezer compartment temperature level is 5.                  ▼ button : Cold → Mid cold → Normal → Mid warm → Warm                  ▲ button : Warm → Mid warm → Normal → Mid cold → Cold</p>													

NO.	Control Function	Control Objects	Contents	Remark																									
			<div data-bbox="639 405 1257 495" style="text-align: center;"> </div> <p data-bbox="608 510 1278 651">2. 1) LED displays the temperature set by the temperature control button, and the bar LED lights in sequence until set temperature. 2) A single upper bar LED on/off according to the COMP. off/on.</p> <table border="1" data-bbox="639 674 1278 831" style="margin-left: auto; margin-right: auto;"> <tr> <td style="text-align: center;"><b>COMP ON</b></td> <td style="text-align: center;"> </td> </tr> <tr> <td style="text-align: center;"><b>COMP OFF</b></td> <td style="text-align: center;"> </td> </tr> </table> <p data-bbox="608 860 1294 1189">3. The COMP. operates when the D-sensor detects above 3.5 °C in initial operation. 4. The C-fan starts after 20 sec. of COMP. operation to reduce noise by separating the COMP. and C-fan operation. 5. F-fan starts after 30 sec. of the COMP. operation to reduce noise. F-fan stops after 30 sec. of the COMP. suspension to use the remaining coolness of evaporator. 6. The temperature levels of the COMP. on/off are as follows. (temperature °C/Resistance kΩ)</p> <table border="1" data-bbox="608 1211 1278 1323" style="margin-left: auto; margin-right: auto;"> <thead> <tr> <th>Classification</th> <th>E.F</th> <th>Warm</th> <th>Mid warm</th> <th>Normal</th> <th>Mid cold</th> <th>Cold</th> </tr> </thead> <tbody> <tr> <td>COMP. OFF</td> <td>-17.5/19.4</td> <td>-19.5/21.7</td> <td>-21/23.6</td> <td>-22.5/25.6</td> <td>-24/27.9</td> <td>-25.5/30.4</td> </tr> <tr> <td>COMP.ON</td> <td>-13.5/15.6</td> <td>-15.5/17.4</td> <td>-17/18.9</td> <td>-18.5/20.5</td> <td>-20/22.3</td> <td>-20/22.3</td> </tr> </tbody> </table>	<b>COMP ON</b>		<b>COMP OFF</b>		Classification	E.F	Warm	Mid warm	Normal	Mid cold	Cold	COMP. OFF	-17.5/19.4	-19.5/21.7	-21/23.6	-22.5/25.6	-24/27.9	-25.5/30.4	COMP.ON	-13.5/15.6	-15.5/17.4	-17/18.9	-18.5/20.5	-20/22.3	-20/22.3	
<b>COMP ON</b>																													
<b>COMP OFF</b>																													
Classification	E.F	Warm	Mid warm	Normal	Mid cold	Cold																							
COMP. OFF	-17.5/19.4	-19.5/21.7	-21/23.6	-22.5/25.6	-24/27.9	-25.5/30.4																							
COMP.ON	-13.5/15.6	-15.5/17.4	-17/18.9	-18.5/20.5	-20/22.3	-20/22.3																							
5	Refrigerator temperature control	COMP F-fan C-fan Damper	<p data-bbox="608 1384 1270 1525">1. Control the refrigerator temperature through switching of the damper. 2. When the refrigerator temperature is same as the graph shown below.</p> <div data-bbox="632 1547 1278 1962" style="text-align: center;"> </div> <p data-bbox="632 1973 1246 2029">◆ F-fan and COMP. are forced to operate by R-sensor, when the temperature is above 9° C.</p>																										

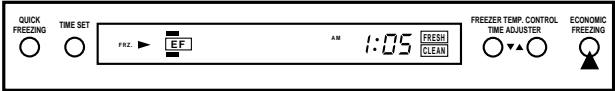
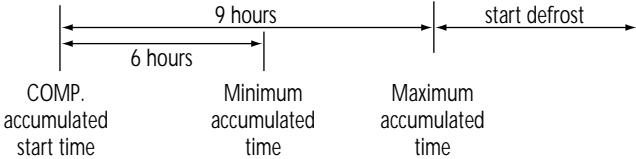
NO.	Control Function	Control Objects	Contents	Remark																																			
6	Economic freezing	COMP. F-fan C-fan LED	<p>1. When the economic freezing button is pressed the LED lights and the operation is started.</p>  <p>2. When press the quick freezing button in the economic freezing mode, quick freezing is operated and returns to previous temperature setting after completion.</p> <p>3. Press the economic freezing button again to return to the previous temperature setting.</p> <p>4. Press the temperature adjust button(▼, ▲) when return to previous temperature setting.</p>																																				
7	Defrost mode	COMP. Heater F-fan C-fan	<p>1. When 9 hours of accumulated time passed, the defrost starts nuconditionally.</p>  <p>The defrost will start, if the door is opened for more than 10 min.</p> <p>2. After minimum 6 hours of COMP. accumulated time, the defrost will start, if the door is opened for more than 10 min.</p> <p>3. Defrost mode time table is shown below.</p> <table border="1" data-bbox="608 1447 1278 2018"> <thead> <tr> <th>Defrost start time</th> <th>Pre-cool</th> <th>Heater on</th> <th>Pause</th> <th>F-fan delay</th> </tr> </thead> <tbody> <tr> <td>COMP.</td> <td></td> <td></td> <td></td> <td></td> </tr> <tr> <td>F-fan</td> <td></td> <td></td> <td></td> <td></td> </tr> <tr> <td>Heater</td> <td></td> <td></td> <td></td> <td></td> </tr> <tr> <td>C-fan</td> <td></td> <td></td> <td></td> <td></td> </tr> <tr> <td>Time</td> <td>           ←→ (Initial defrost 6 min operation) delay            ←→ 40 min. Pre-cool step is canceled, when D-sensor detects -27.5° C         </td> <td>           ←→ 45 min (D-sensor failure)            ←→ 90 min. heater failure            The heater is off, when D-sensor detects above 13° C         </td> <td>←→ 7 min.</td> <td>←→ 5 min.</td> </tr> <tr> <td>The priority order of the quick freezing mode in normal defrost mode.</td> <td>The quick freezing mode is prior to Pre-cool step in defrost mode.</td> <td>Defrost mode is prior to quick freezing mode.</td> <td>←</td> <td>←</td> </tr> </tbody> </table>	Defrost start time	Pre-cool	Heater on	Pause	F-fan delay	COMP.					F-fan					Heater					C-fan					Time	←→ (Initial defrost 6 min operation) delay ←→ 40 min. Pre-cool step is canceled, when D-sensor detects -27.5° C	←→ 45 min (D-sensor failure) ←→ 90 min. heater failure The heater is off, when D-sensor detects above 13° C	←→ 7 min.	←→ 5 min.	The priority order of the quick freezing mode in normal defrost mode.	The quick freezing mode is prior to Pre-cool step in defrost mode.	Defrost mode is prior to quick freezing mode.	←	←	
Defrost start time	Pre-cool	Heater on	Pause	F-fan delay																																			
COMP.																																							
F-fan																																							
Heater																																							
C-fan																																							
Time	←→ (Initial defrost 6 min operation) delay ←→ 40 min. Pre-cool step is canceled, when D-sensor detects -27.5° C	←→ 45 min (D-sensor failure) ←→ 90 min. heater failure The heater is off, when D-sensor detects above 13° C	←→ 7 min.	←→ 5 min.																																			
The priority order of the quick freezing mode in normal defrost mode.	The quick freezing mode is prior to Pre-cool step in defrost mode.	Defrost mode is prior to quick freezing mode.	←	←																																			

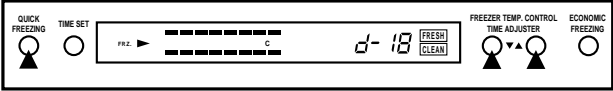
NO.	Control Function	Control Objects	Contents	Remark
8	Forced defrost	COMP. F-fan	<p>1. Press the quick freezing button 5 times, when press time set button and then forced defrost mode is started.</p>  <p>2. It starts for heater on step without Pre-cool step.</p> <p>3. After 14 hours of forced defrosting operation, regular defrosting starts. (Ignore accumulated COMP. time during forced defrost)</p>	
9	Prevent COMP. restarting	COMP. F-fan C-fan	<p>1. Restart in 6 min. after COMP. off</p>	
10	Error display	LED	<p>1. Press the quick freezing button 5 times, when press both the freezer temperature button and then each sensors' temperature and error code is displayed for 8 min.</p>  <p>2. Pressing the time set button each time to change display status. (D-sensor → R-sensor → F-sensor → Error code → D-sensor)</p> <p>3. Error code is displayed in the following sequence : F1 → R1 → D1 → D0 → F3 → C1 ◆ Error code is referred to self-diagnosis table.</p> <p>4. If all errors are removed, error code is automatically reset.</p> <p>5. Press the quick freezing button 5 times, when press both the freezer temperature button again, and then remove the error display on LED.</p>	

### 3) Self-diagnosis table

Code	Content	Perception method	Refrigerator operation state
F 1	F-sensor malfunction	<ul style="list-style-type: none"> <li>- Short circuit</li> <li>- Wire disconnection</li> </ul>	<ul style="list-style-type: none"> <li>- The refrigerator is run at 60% power with a 40 minute period.</li> <li>- When the refrigerator compartment is over frosted. the operation is forcibly stopped, then returns to a 40 minute period operation.</li> </ul>
R 1	R-sensor malfunction	<ul style="list-style-type: none"> <li>- Short circuit</li> <li>- Wire disconnection</li> </ul>	<ul style="list-style-type: none"> <li>- Ignores R-sensor operation</li> </ul>
D 1	D-sensor malfunction	<ul style="list-style-type: none"> <li>- Short circuit</li> <li>- Wire disconnection</li> <li>- When the D-sensor temperature is over -5°C while the compressor is off.</li> </ul>	<ul style="list-style-type: none"> <li>- Heater turns on for 45 minutes irrespective of D-sensor.</li> </ul>
D 0	Door switch malfunction	<ul style="list-style-type: none"> <li>- When the door switch is left open continually for an hour.</li> </ul>	<ul style="list-style-type: none"> <li>- The F-fan operates irrespective of the door switch when the compressor is on.</li> </ul>
F 3	Defrost malfunction	<ul style="list-style-type: none"> <li>- When the D-sensor turns off not by 13°C but by a 90 minutes period while the heater is on.</li> </ul>	<ul style="list-style-type: none"> <li>- Normal operation.</li> </ul>
C 1	Cycle malfunction Compressor malfunction	<ul style="list-style-type: none"> <li>- When the temperature of the D-sensor is over -5°C although the compressor has been running for 3 hours non-stop.</li> </ul>	<ul style="list-style-type: none"> <li>- Normal operation.</li> </ul>



#### 4) circuit and wiring diagram

