

DENON

Hi-Fi Component

SERVICE MANUAL

STEREO CD PLAYER

MODEL DCD-1800



NIPPON COLUMBIA CO., LTD.

TABLE OF CONTENTS

FEATURES	2
SPECIFICATIONS	3
WARNING	3
CONTROLS AND THEIR DESCRIPTION	4 ~ 5
NOTE FOR HANDLING OF LASER PICK-UP	6 ~ 7
DISASSEMBLY	8 ~ 12
ADJUSTMENT OF MECHANISM UNIT	13 ~ 18
ADJUSTMENT OF SERVO SYSTEM	19 ~ 23
SIGNAL PROCESS	23
PARTS LIST OF P.W. BOARD	24 ~ 27
PARTS LIST OF EXPLODED VIEW	28
EXPLODED VIEW OF CABINET	29
PARTS LIST OF MECHANISM UNIT	30
EXPLODED VIEW OF MECHANISM UNIT	31
P.W. BOARD	32 ~ 34
FUNCTION TABLE OF CPU TERMINAL	35 ~ 36
SEMICONDUCTORS	37
WIRING DIAGRAM	38
SCHEMATIC DIAGRAM	39 ~ 40

FEATURES

The DCD-1800 employs a DENON Super Linear Converter to prevent degradation of sound quality in the PCM playback system, assuring accurate reproduction of recorded sound. The CD player is capable of reproducing the actual musical scene as it is in conjunction with carefully selected parts.

SPECIFICATIONS

AUDIO

No. of channels:	2 channels
Frequency response:	5 ~ 20,000 Hz \pm 0.5 dB
Dynamic range:	95 dB
Signal-to-noise ratio:	96 dB
Harmonic distortion:	0.003% (1 kHz)
Channel separation:	94 dB (1 kHz)
Wow and flutter:	Less than measuring limit
Output voltage:	2.0 V r.m.s.

DISCS FOR USE

Playing time:	Compact disc
Diameter:	60 min./side (Max. 79.8 min./side) 120 mm

SIGNAL FORMAT

Sampling frequency:	44.1 kHz
Quantization:	16-bit linear/channel
Transmission bit rate:	4.3218 M bits/sec.

PICKUP

System:	Objective lens driving system laser pickup
Lens drive system:	Two-dimensional parallel driving
Light source:	Semiconductor laser
Wavelength:	800 nm

GENERAL CHARACTERISTICS

Power supply:	50/60 Hz, Voltage is shown on rating label.
Power consumption:	28 W
Dimensions:	434 (width) x 110 (height) x 372 (depth) mm 464 (width) x 110 (height) x 372 (depth) mm (with decorative wood board)
Weight:	8.9 kg 9.5 kg (with decorative wood board)

FUNCTIONS AND DISPLAY

Functions:	Direct selection, quick selection, selection by programming, repeat performance, A — B repeat, pause, skip monitor, index search, and intro search
Display:	Cut no., index, time, and program
Other functions:	Headphone jack, level (headphone level control), timer switch

ACCESSORIES:	Connecting pin cord
--------------	---------------------

* Design and specifications are subject to change without notice.

WARNING:

Although the laser beam from the object lens is not visible, it can be harmful to human body depending on the optical output.

- While the laser diode is turning on do not look inside the lens with or without a magnifying lens.
- Use the laser power meter for checking laser output.
- Use infrared rays viewers or infrared ITV cameras to observe the laser beam.

CONTROLS AND THEIR DESCRIPTION

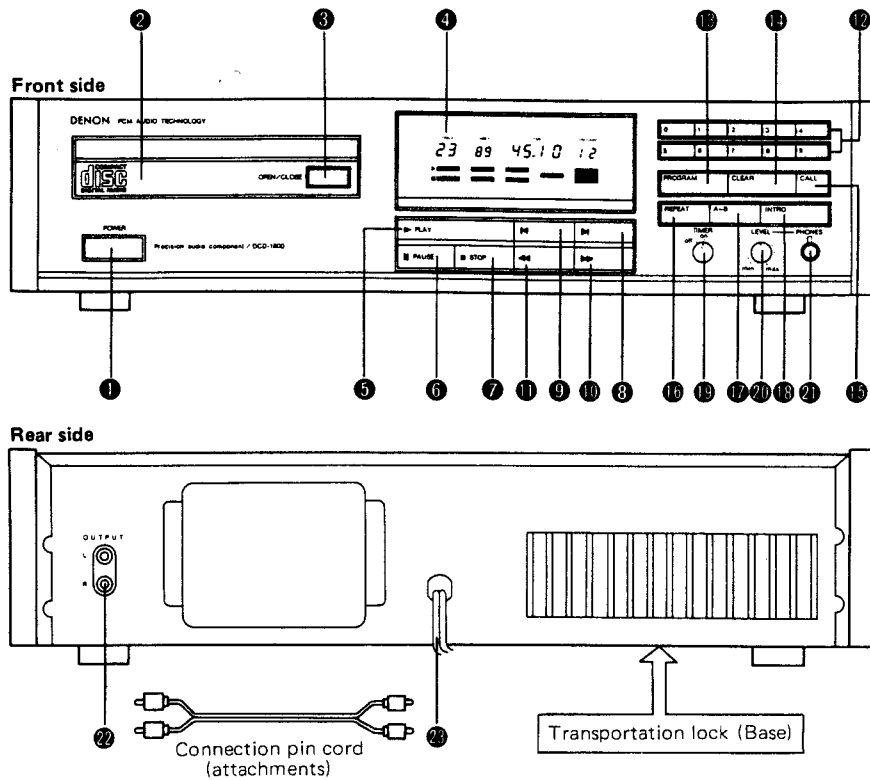

1 Power Switch (POWER)

- Press the switch and the power is turned ON.
- When the power is turned ON, TRACK, INDEX, TIME and PROGRAM on the indicators (4) light up, and (-----) also lights up in the display.
- If a disc is loaded at this time, (00 00 00 00 01) lights up in the display, and **DISC SET** and **NEXT NO** located on the lower side of the indicator light up.

2 Disc Holder

- The disc is loaded in this disc holder.
- By pressing the disc holder open/close button (▲ OPEN/CLOSE) (3), the disc holder can be opened.
- To close the disc holder, press the disc holder open/close button (3).

- The disc holder can be closed also by pressing the play button (▶ PLAY) (5).

3 Disc Holder Open/Close Button (▲ OPEN/CLOSE)

- Press this button when the disc holder (2) is to be opened/closed.
- When the button is pressed once, the disc holder (2) is ejected. It is closed by pressing it again.
- If a disc is set, the disc rotates for several seconds after the disc holder is closed, and then stops. At this time, **DISC SET** on the indicator (4) lights up.

4 Indicators

- For description of the display, refer to the following figure:

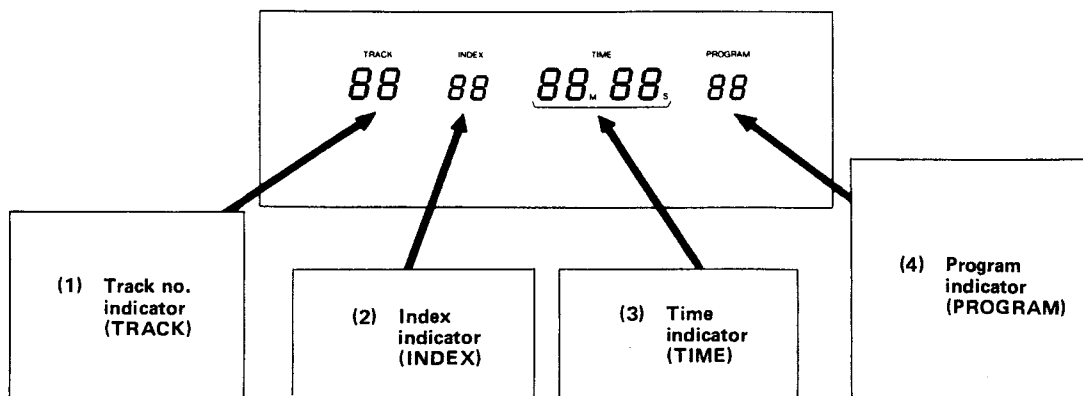

(1) Track No. Indicator (TRACK)

- The track no. being played is indicated.
- When the contents programmed by the call button

are to be confirmed, the programmed track count is indicated sequentially.

(2) Index Indicator (INDEX)

Index no. of the track being played is indicated.

(3) Time Indicator (TIME)

Performance time or performance lapsed time is indicated in minutes (M) and seconds (S).

(4) Program Indicator (PROGRAM)

- The track no. to be played next is indicated.
- The number selected by the track no. button (0 ~ 9) is indicated.
- When the contents programmed by the call button are to be confirmed, track nos. are indicated sequentially.

⑤ Play Button (▶ PLAY)

- Press this button when the disc is to be played.
- When the button is pressed, the ▶ **PLAY** indicator lights up, and track no. being played, its index no. and performance lapsed time (TIME) are indicated.
- Upon completion of playback of the final track, ▶ **PLAY** goes out, and the unit stops.

⑥ Pause Button (⏸ PAUSE)

- Press this button when playback is to be temporarily halted.
- If the pause button is pressed during playback, playback is suspended and ▶ **PLAY** goes out. **PAUSE** lights up instead.
- To reset the pause status, press the play button ⑤.

⑦ Stop Button (■ STOP)

- Press this button when playback is to be stopped.
- The rotation of the disc is stopped and the numeral on the indicators is changed to (00 00 00 00 01).

⑧ Fast Forward Button (▶▶)

- Press this button when the pickup is to be forwarded to the head of a desired track quickly.
- The head of the track is forwarded according to the operation count of this button during playback or pause.

⑨ Fast Reverse Button (◀◀)

- Press this button when the pickup is to be moved back to the head of a desired track quickly.
- The head of the track is moved back according to the operation count of this button during playback or pause.

⑩ Fast forward skip button (▶▶)

- Press this button when playback is to be fast forwarded.
- If **PLAY** is lit, the disc is fast forwarded and sound is audible while the button is pressed.
- If **PAUSE** is lit, no sound is generated when the disc is fast forwarded.

⑪ Fast reverse skip button (◀◀)

- Press this button when fast reverse is desired.
- If **PLAY** is lit, the disc is fast reversed and sound is audible while the button is pressed.
- If **PAUSE** is lit, no sound is generated when the pickup is fast reversed.

⑫ Track No. Button (0 ~ 9)

- Press this button when playback is to be programmed, or a track no. is to be selected for start from the head.

⑬ Program Buttons (PROGRAM)

- Press this button when playback is to be programmed.
- Track nos. selected by the track no. buttons are stored (up to 15).

⑭ Clear Button (CLEAR)

- Press this button when a programmed track no. is to be corrected, or reset.
- If this button is pressed, immediately after PROGRAM button operation, only the immediately preceding track is cleared.
- By pressing the CLEAR button twice, all the programmed tracks will be cleared.

⑮ Call Button (CALL)

- Press this button when a programmed track no. is to be confirmed.

⑯ Repeat Button (REPEAT)

- Press this button when playback is to be repeated.

⑰ A – B Button (inter-point repeating performance)

- Use this button when a desired music between two optional points is to be played repeatedly.
- By pressing the button once, point A is stored, and by pressing it again, point B is stored. Desired music between points A and B will be played repeatedly.
- Pressing the button for the third time resets the points.

⑱ Intro Button (INTRO)

- Press this button when the start of each track recorded on the disc is to be played sequentially for 10 seconds each.
- Pressing the button again resets this performance mode.

⑲ Timer Switch (TIMER)

- Use when first track is to be played according to a timer setting. (For using the timer, refer to TIMER CONTROLLED PLAYBACK.)

⑳ Volume control (LEVEL)

- Use when the output level (volume) of the headphone jack is to be adjusted.

㉑ Headphone Jack (PHONES)

- When a headphone is used, listen at the desired volume. (Headphone is not supplied.)

㉒ Output Terminal (OUTPUT)

- Connect the output terminal to the input terminal of the amplifier. (For connection, refer to CONNECTION TO AMPLIFIER.)

㉓ Power Cord

- Connect the power cord to the auxiliary plug socket of the amplifier, or to the AC outlet.

NOTE FOR HANDLING OF LASER PICK-UP

CONFIGURATION

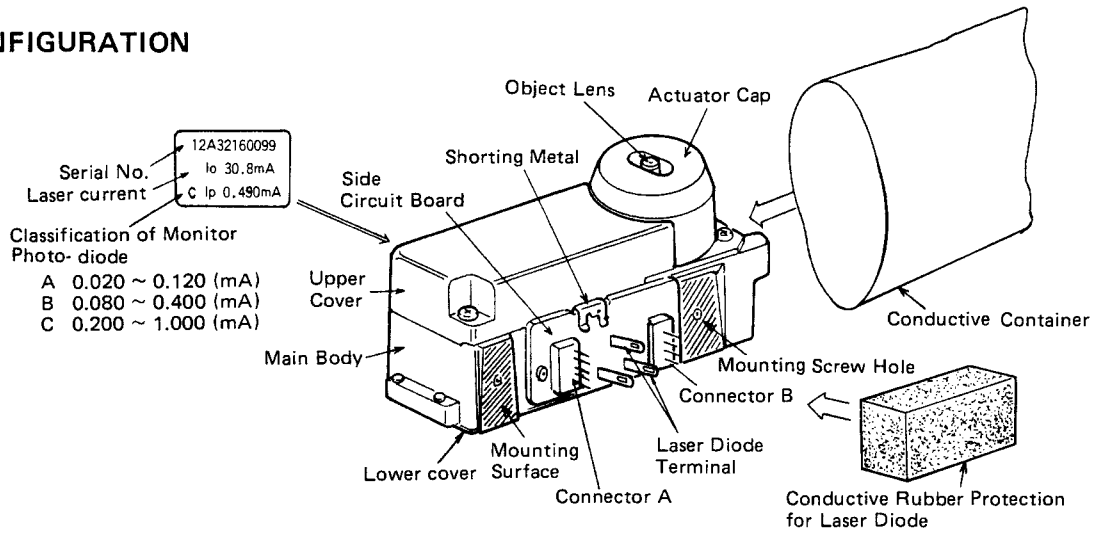

CONNECTIONS

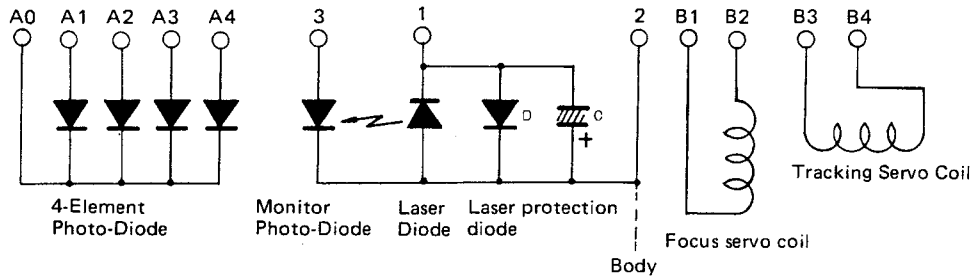

ARRANGEMENT OF 4-ELEMENT PHOTO-DIODE VIEWED from sensing side

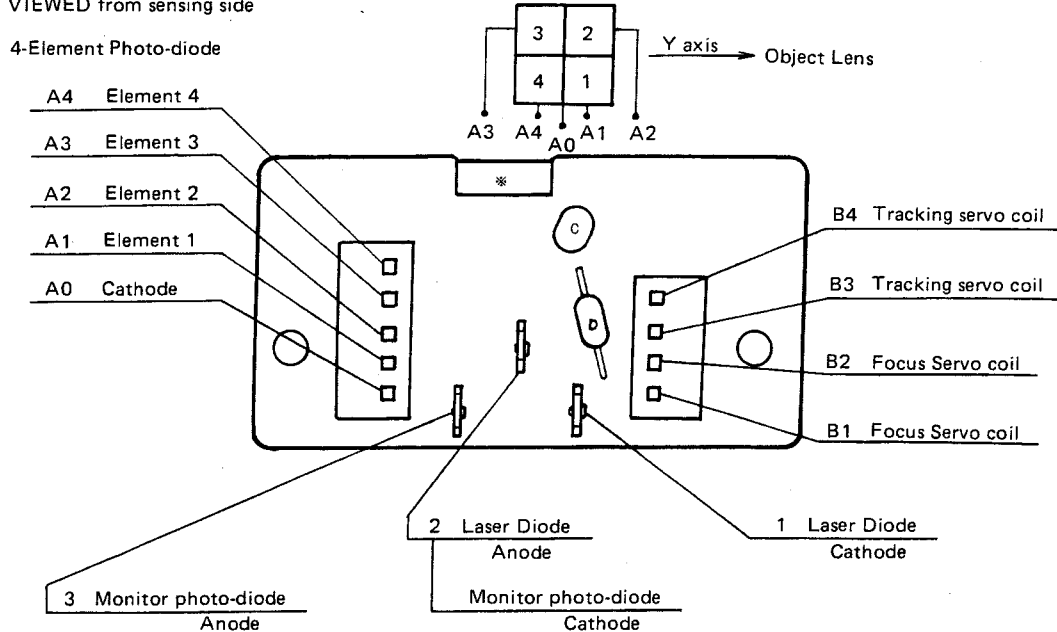

1. PROTECTION OF LASER DIODES

Laser diodes are so sensitive to such pulsive electrical noises as static voltage or surge current that their reliability may be decreased or completely destroyed.

Take intensive precautions against all kinds of static voltage problems as well as the following examples.

- Electrically ground workbenches, measuring instruments, jigs, tools, etc. at the same potential as the ground line of the power supply.
- Use wrist straps for grounding workers' bodies as well as using non-leakage soldering iron with grounding for tip. It should be especially noted when wearing a synthetic dress or the air is dry.
- Do not attempt checking simply with circuit tester or oscilloscope probes on the laser terminals. Do not apply voltage with poorly made voltage source or with temporary contact pins or clips.
- Although a shorting metal is provided in contact with the laser diode leads on the pattern side of the circuit board in the event of unit shipment, this shorting metal can lose its conductivity due to vibrations during transportation or oxidation. Take sufficient precautions even when the shorting metal is on. For dismounting the laser diode, turn off the power after turning down the optical output (work current), short the laser diode leads with the shorting metal or by soldering the leads, and then remove connections. For mounting, make connections, remove the short circuit, turn on the power and then adjust the optical output.
- Make sure that the unit is not handled with the shorting metal removed nor left near the appliances that emit high frequency surge voltages. For storing the unit, be sure to short the laser diode leads with the shorting metal or by soldering the leads and put in a conductive container.
- The optical output should not exceed (even momentarily) the maximum ratings of
0.35mW at 45°C, or
0.7mW at 20°C.

2. HANDLING OF ACTUATOR

The actuator precisely controls the object lens.

For maintaining this precision, each part is finished, assembled and adjusted with the highest care.

Do not attempt careless disassembly, especially do not take apart the actuator assembly.

- The object lens is supported by a precision spring. Be careful not to apply mechanical stresses such as by excessive vibrations or dropping the unit.
- Inside the actuator cap covering around the object lens, there is a strong permanent magnet. Handle with care so that any foreign object (especially metals) will not get inside, or the unit will not be placed near magnetic substances.

3. CLEANING OF LENS

If the object lens is stained or tarnished, the specified characteristics including the emitting power may be deteriorated.

- Stain on the lens should be cleaned with raveling-free cotton swabs or lens cleaning paper for cameras moistened with a mixture of alcohol/ether (3/7) or cleaning solution for cameras. Wipe the lens gently so that the supporting spring will not be deformed.
- Do not handle or store the lens in places subject to oil stain or dew formation, but handle or store it in dust-free places with little change of temperature.

DISASSEMBLY

1. How to remove "TOP COVER" and FRONT PANEL. (Fig. 1)

- (1) Remove 8 screws (A) at both sides and remove the WOOD BOARDS.
- (2) Remove 4 screws (B) at both sides so that the TOP COVER can be removed.
- (3) Remove 2 signal process wiring board fixing screws (C) and pull out the wiring board.
Remove connectors leading from the FRONT PANEL to the wiring board and to other wiring boards.
- (4) Remove 6 front panel fixing screws (D) (top and bottom) and take out the FRONT PANEL.

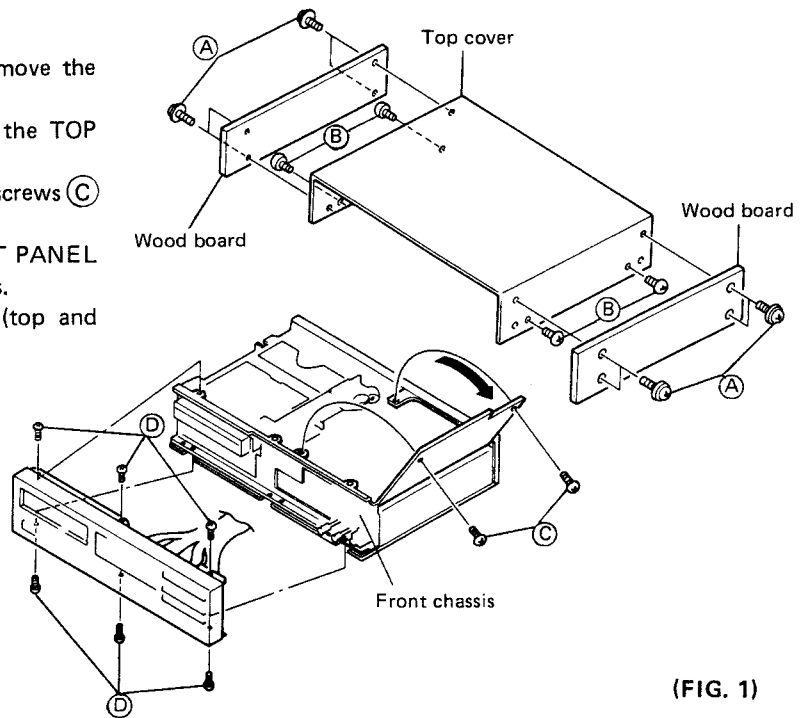

(FIG. 1)

2. How to remove MECHANISM UNIT.

- (1) Remove the TOP COVER and the FRONT PANEL.
- (2) Remove 2 fixing screws (E) and remove the 2 SWITCH BRACKETS (L). (Fig. 2)
- (3) Pull out the LOADING UNIT and pull off the SWITCH CONNECTOR from the POWER SWITCH. (Fig. 2)

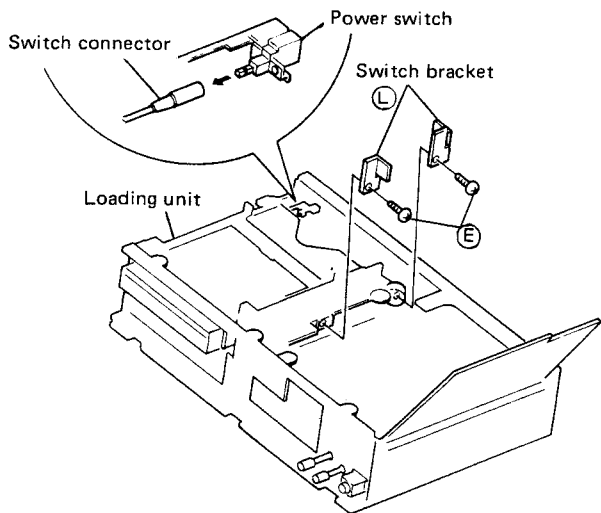

(FIG. 2)

- (4) Remove 2 mechanism fixing screws (F) at the bottom cover. (Fig. 3)

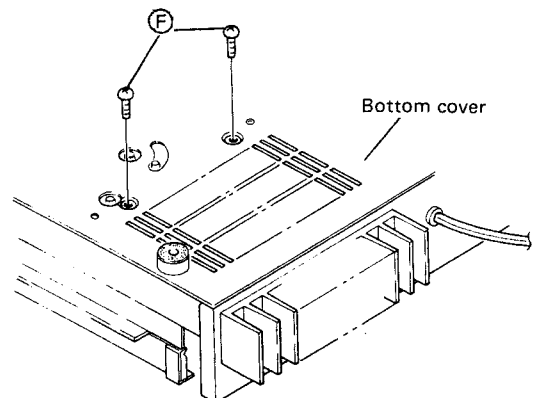

(FIG. 3)

- (5) Remove 5 mechanism fixing screws (G). (Fig. 4)
- (6) Remove 6 screws (H) and detach the FRONT CHASSIS. (Fig. 4)
- (7) Unfasten the CONNECTOR linking the mechanism unit and main body. Lift the MECHANISM UNIT in the arrow direction and take out. (Fig. 4)

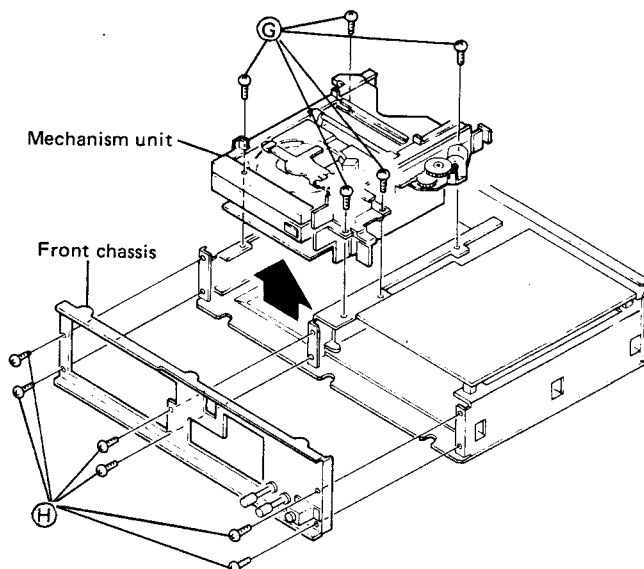

(FIG. 4)

3. How to disassemble LOADING UNIT. (Fig. 5)

- (1) Remove the FRONT PANEL and the FRONT CHASSIS.
- (2) Remove the screw (I) and take off the CLAMPER.
- (3) Remove 2 screws (J) and take off the 2 LOADING STOPPERS.
- (4) Remove 2 screws (K) and take out the LOADING MOTOR UNIT in the arrow direction.
- (5) Pull out the LOADING UNIT (tray) in the arrow direction.
(Be careful 2 CROSSED ROLLERS will come out at this time also.)

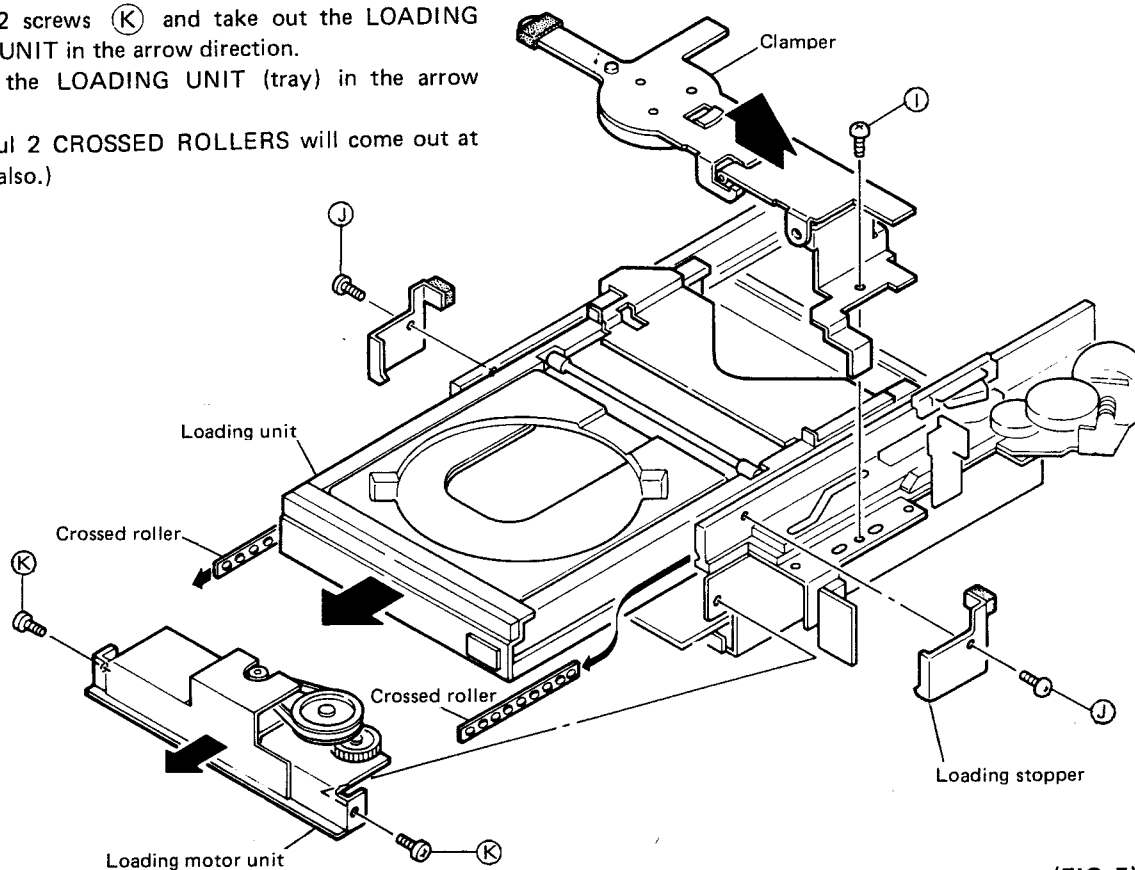

(FIG. 5)

4. How to remove and place **CROSSED ROLLERS** (For replacing **CROSSED ROLLERS ONLY**).

4-1 How to remove **CROSSED ROLLERS**. (Fig. 6)

- (1) Pull out the **LOADING TRAY** about a half way.
- (2) Remove screws ① and ⑤ and remove **GUIDE RAIL (L)** ④.
- (3) Take out the **CROSSED ROLLERS** ②, ③ from the rear.
(Be careful in handling as each roller can become loose.)
- (4) Wipe off grease from V-shape guides and the **GUIDE RAILS (L)** ④ and **(R)** ⑥.

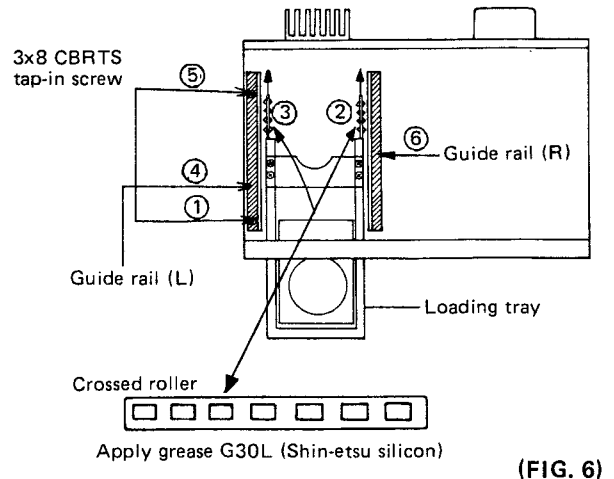

(FIG. 6)

4-2 How to place **CROSSED ROLLERS**. (Fig. 7)

- (1) Attach the **GUIDE RAIL (L)** ④ and pre-fix the screw ① in the front.
- (2) Slide the **CROSSED ROLLER (R)** ② in the right side V-shape guide as indicated arrow.
(Be careful each roller easily become loose.)
- (3) Slide the **CROSSED ROLLER (L)** ③ in the left side.
- (4) Fix the screw ⑤ at the rear of the **GUIDE RAIL (L)** ④. After adjusting the play of the **LOADING TRAY**, tighten screws ① and ⑤.

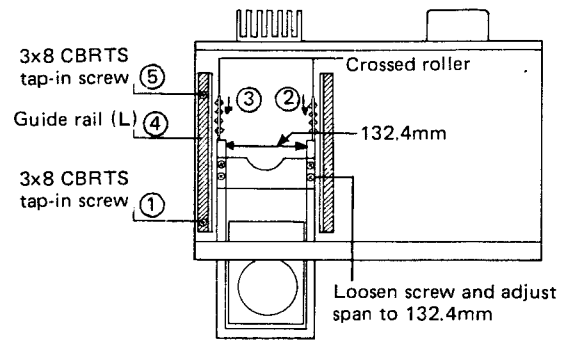

(FIG. 7)

4-3 Adjusting the play of the **LOADING TRAY**. (Fig. 8)

Obtain a space of 1.2mm each side between the **LOADING TRAY** and the V-shape guides. (screw ⑤)

Allow no play when the **LOADING TRAY** is fully open.

NOTE: At the completion of assembly, have the mechanism function and make sure that there is a play of 0.5mm or more from side to side when the **LOADING TRAY** is closed.
The **TRAY** may fail to lower if there is no play.

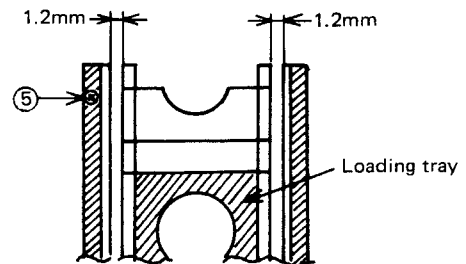

(FIG. 8)

5. How to mount **LOCK ARM**. (Fig. 9, 10, 11)

Mount and adjust the **LOCK ARM** while the **LOADING TRAY** is closed.

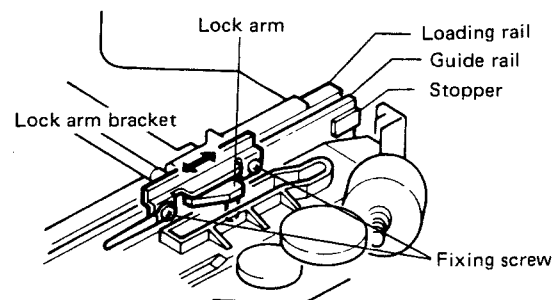

(FIG. 9)

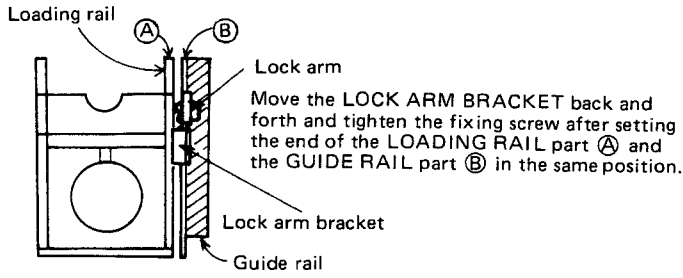

(FIG. 10)

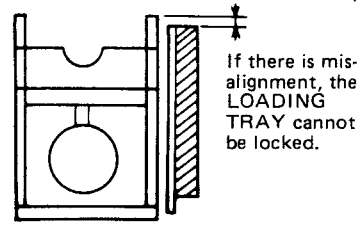

(FIG. 11)

6. How to mount CLAMPER. (Fig. 12)

Place the CLAMPER towards and parallel to the front panel and tighten the fixing screw. (Mount the CLAMPER by confirming MCES value minimum. Fluctuations should be 10% or less.)

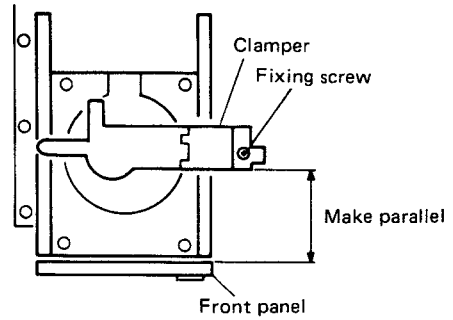

(FIG. 12)

7. Dismounting of PICK-UP and SLIDE MOTOR UNIT. (Fig. 13)

- (1) Remove the connector from the PICK-UP. (In this state loading unit is mounted on the chassis.)
- (2) Unfasten 3 screws (Q) and remove the ARM STOPPER and the FLAT SPRING.
- (3) By shifting the SLIDE MOTOR UNIT in the arrow direction, pull up the PICK-UP ARM off the shaft.
- (4) Remove 3 screws (R) and dismount the PICK-UP SUPPORT from the PICK-UP ARM.
- (5) Loosen screw T, remove 2 screws (S) and detach the PICK-UP SUPPORT.

WARNING: DO NOT TOUCH the pick-up TERMINALS by hand. Static voltage may damage the LASER DIODES.

- (6) The SLIDE MOTOR UNIT can be pulled out after removing the 3E-RING and SPRING.

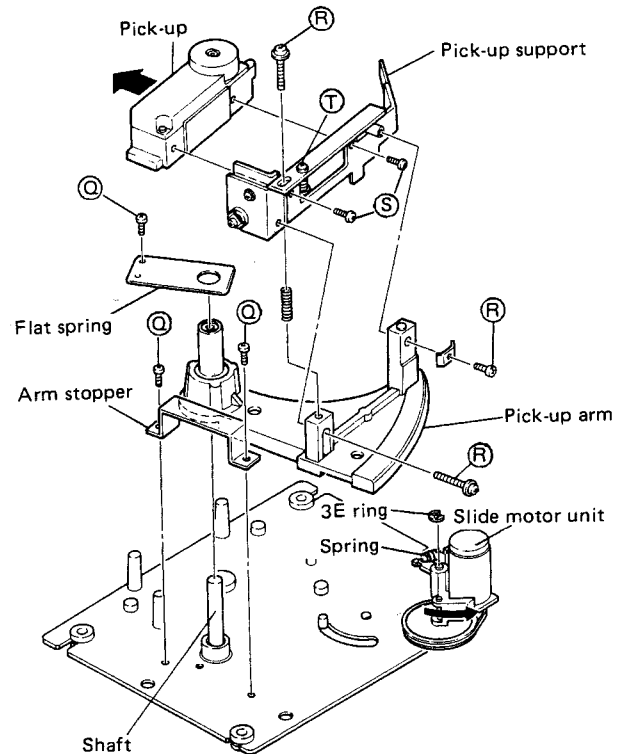

(FIG. 13)

8. Mounting of PICK-UP.

Follow procedures in item 7 reversely from (5) to (1).

**9. Disassembling of SLIDE MOTOR section
(Fig. 14)**

- (1) Remove the BELT and the PULLEY.
- (2) Remove the screw and take off the SLIDE MOTOR.

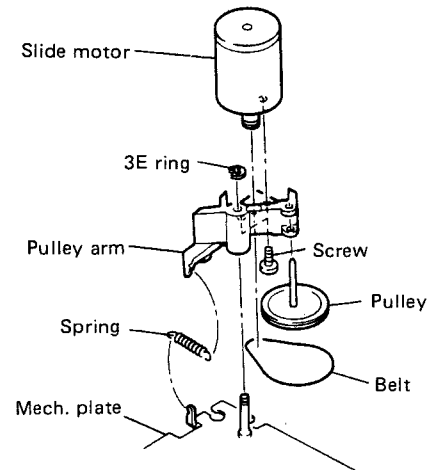

(FIG. 14)

**10. Dismounting of POWER SUPPLY WIRING
BOARD. (Fig. 15)**

- (1) Remove TOP COVER.
- (2) Pull out the connector from the BOARD and remove screw (T).
- (3) Unfasten 2 screw (U) and draw out the BOARD to rear side by holding the RADIATOR.

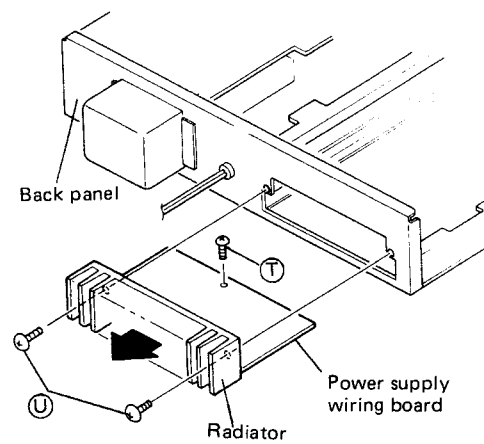

(FIG. 15)

ADJUSTMENT OF MECHANISM UNIT

1. Preparation. (Fig. 16)

- (1) Instruments: Adjustment adaptor
Adjustment disc (90mm diam.)
Oscilloscope
- (2) Keep the power "off".
- (3) If readjustment of laser power is needed in such cases when the pick-up is replaced, be sure to turn VR2 on the motor wiring board KU-5130 fully clockwise. VR2 becomes accessible from front by removing the front panel.
- (4) Turn on the power, open the disc tray and then turn off the power again.
Remove the cord CB201 from the signal process wiring board KU-5150 and remove the loading stay.

CAUTION: Wires are clamped on the loading stay. Be careful not to touch the live (high voltage) parts.

- (5) Turn on the power again. Press the OPEN/CLOSE switch on the disc tray. (The loading slide motor does not function as the wires have been removed.) Press the close-acknowledgement switch (a microswitch at the side of the power switch), and the clasper will come down.

NOTE: When loading a disc manually, lift up the clasper by hand and place the disc carefully from the side.

- (6) Turn off the power, connect the adjustment adaptor to the IC16 on the servo wiring board (KU-5140) with all the switches on the adaptor OFF.

ADJUSTMENT ADAPTOR

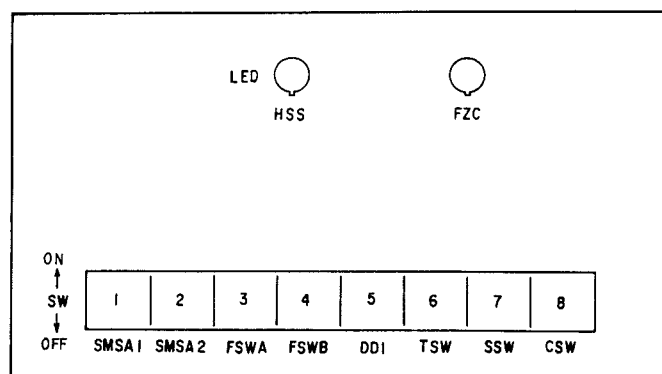

(FIG. 16)

2. Adjustment of motor amp. off-set voltage. (Fig. 17)

- (1) Connect an oscilloscope to the test points (TP1 → ch1, TP2 → ch2, TP0 → GND) on the motor wiring board.
- (2) Remove connector CB-607 from the servo wiring board.
- (3) Turn on the power. Set the oscilloscope at the "Chop" tracing mode.

- (4) Select the oscilloscope input to GND position and set the vertical calibration at 0 level. Set it to DC mode after calibration.

- (5) Set the oscilloscope voltage range to 0.1V or less. By adjusting VR5, VR6 obtain 2 horizontal lines come to the center 0 level position.

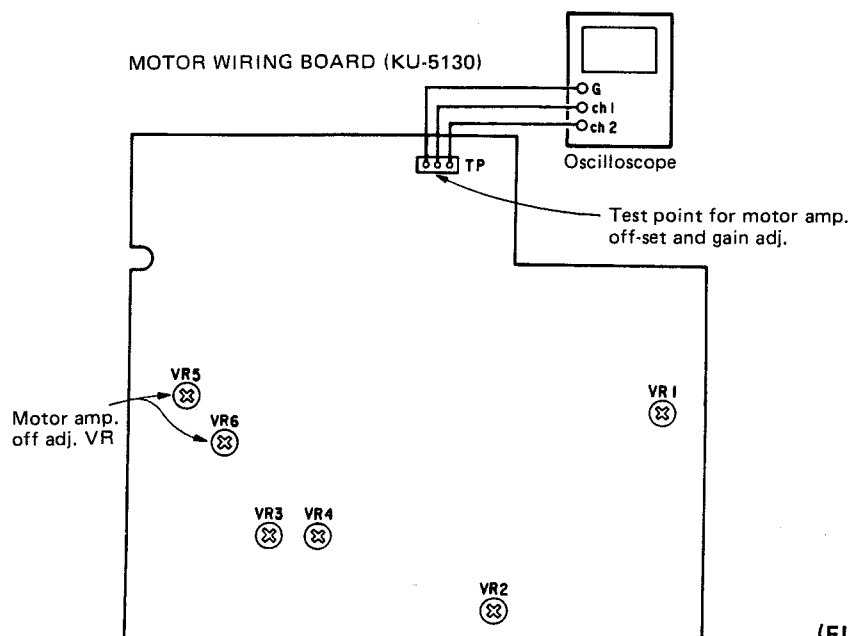

(FIG. 17)

3. Adjustment of motor amp. gain. (Fig. 18)

- (1) Connect a 220-ohm resistor in series to Pin ③ of the motor wiring board connector cord CC102, and apply a DC voltage of $-0.5V$ between Pin ④ and the ground.
- (2) Adjust VRs 3 and 4 so that the amplitude of both driving waveforms on the oscilloscope becomes 6 Vp-p (peak to peak).
- (3) Since this gain adjustment may shift the off-set voltages of motor amps, re-adjust VRs 5 and 6 if necessary. (Refer to 2(5).)

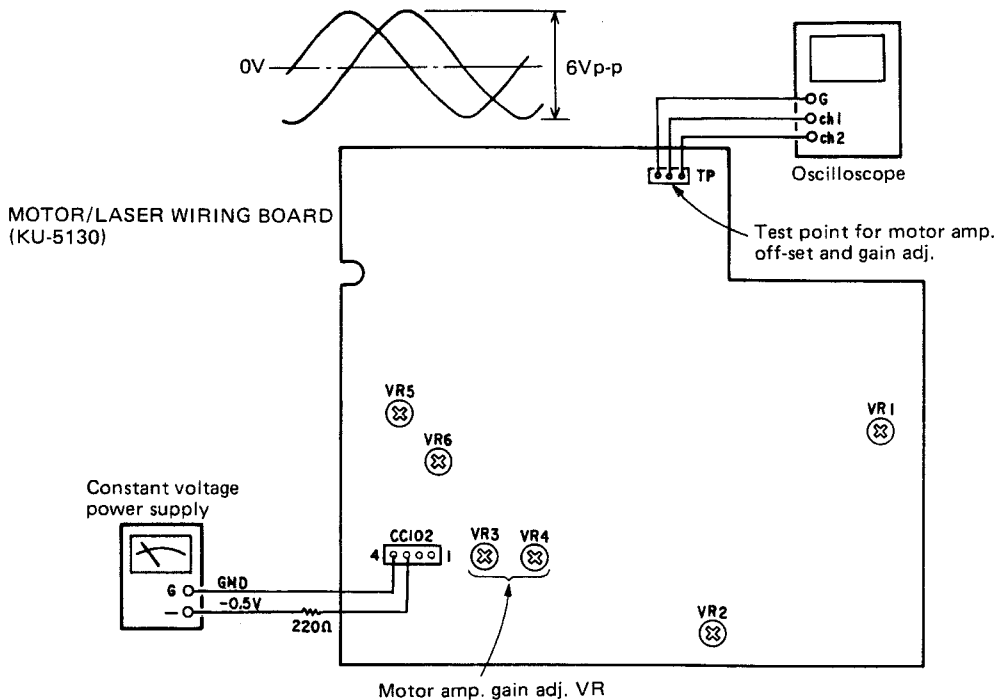

(FIG. 18)

4. Adjustment of laser power

- (1) Turn the power on, the laser beam is emitted. Be careful not to receive the laser beam directly in your eyes.
- Place the sensor part of the laser power meter in contact with the pick-up lens. Adjust VR2 on the motor wiring board so that the laser output becomes $0.3mW \pm 0.01mW$.

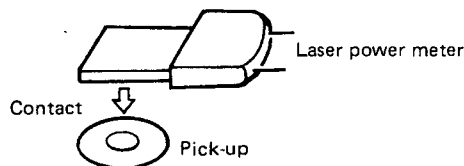

(FIG. 19)

5. Adjustment of the stopper.

(Two mounting types are manufactured for PHOTO-INTERRUPTER. One is mounted on the exclusive wiring board, and the other one is mounted on the motor wiring board.)

5-1 Adjustment of photo-interrupter wiring board. (Exclusive wiring board – Fig. 20, 21)

- (1) Connect the oscilloscope or DC voltmeter to Pin ② (hot side), Pin ④ (GND).
- (2) Load the transparent disc on the spindle motor, and manually adjust the pick-up to bring the center of the lens at 1mm out side to outer guide circle ($\phi 49$). (Be careful not to touch the laser terminals and the moulded parts of pick-up to avoid static voltage application.)
- (3) Move the photo-interrupter wiring board and place it at the point the voltage varies 5 ~ 0V or 0 ~ 5V on the scope or the voltmeter. Tighten the fixing screw and apply a locking dope on the screw. (The stopper does not need adjustment.)
- (4) Insert connector cord CC102 of the motor wiring board into the CB607 on the servo wiring board.

MOTOR/LASER WIRING BOARD (KU-5130)

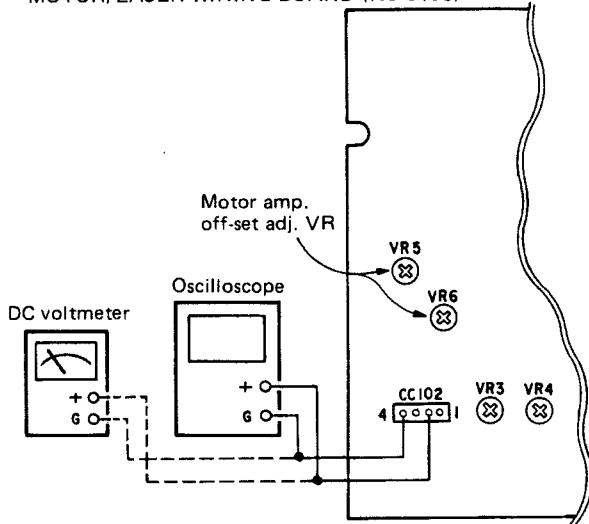

(FIG. 20)

PHOTO-INTERRUPTER ON EXCLUSIVE WIRING BOARD

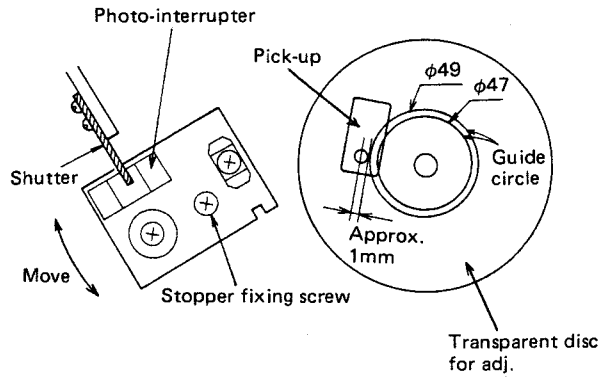

(FIG. 21)

5-2 Adjustment of photo-interrupter mounted on the motor wiring board. (Fig. 20, 22)

- (1) Connect the oscilloscope or DC voltmeter to Pin ② (hot side), Pin ④ (GND).
- (2) Check voltage change from high to low when the shutter passes across the photo-interrupter by moving the pick-up from outer side to inner side by hand. (Adjustment not required, check only.)
- (3) Load the transparent disc on the spindle motor, and manually move the pick-up to bring the center of the lens at guide circle $\phi 47 +0, -1\text{mm}$ diam. (Be careful not to touch the laser terminals and the moulded parts of pick-up to avoid static voltage application.)
- (4) Adjust the stopper position to hit the metal plate and tighten the fixing screw.
- (5) Insert connector cord CC102 of the motor wiring board into the CB607 on the servo wiring board.

PHOTO-INTERRUPTER ON MOTOR WIRING BOARD

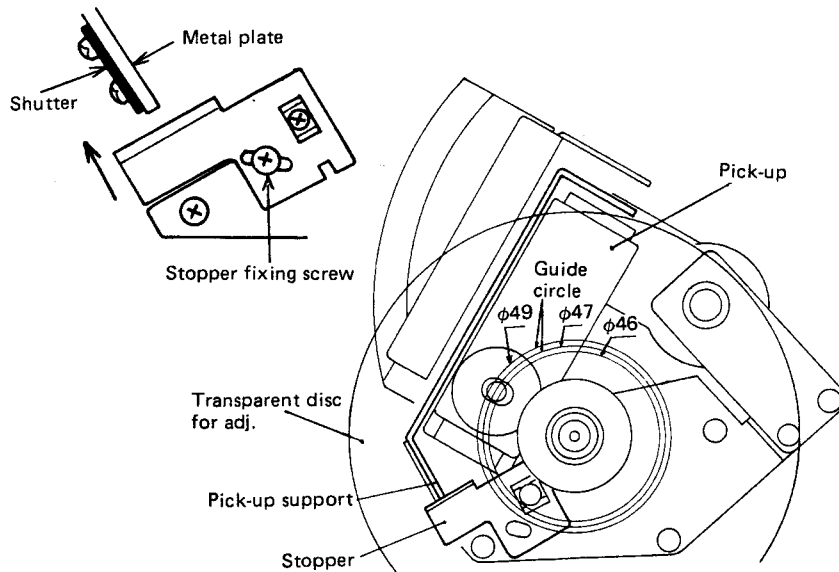

(FIG. 22)

6. Preadjustments (Fig. 23, 24)

- (1) Turn off the power. Unload the transparent disc and load the adjustment disc (90mm dia.)
- (2) Connect the oscilloscope to YPHF (HOT), YP411 (GND) on the signal processing wiring board.
- (3) Turn on the power.
- (4) Turn on switches SMSA-1 (Full torque) and SMSA-2 (Constant speed) on the adjustment adaptor consecutively. When the disc making revolution turn off SMSA-1.
- (5) Adjust the pick-up height adjustment screw to obtain a HF (High Frequency) waveform.
- (6) Set VR1 on the motor wiring board at mechanical center.
- (7) Turn on switch DDI on the adjustment adaptor. Then turn on switches FSW-A FSW-B, CSW and then turn off switch SMSA-2.
Make sure LEDs for FZC and HSS light. If they do not light, start from (5) above again.
- (8) Adjust VR1 on the motor wiring board to obtain the highest HF waveform output.
- (9) Adjust the jitter direction adjustment screw on the pick-up to obtain maximum amplitude of the HF waveform.
- (10) Adjust the radial direction adjustment screw to obtain maximum amplitude of the HF waveform.
- (11) Turn on switch TSW on the adjustment adaptor, then turn on Switch SSW.
Check on the oscilloscope that an eye pattern (EFM signal) can be observed.
- (12) Adjust VR1 on the motor wiring board to obtain the clearest eye pattern.
If there is a considerable amount of jitter along the time axis, proceed from (9) again.

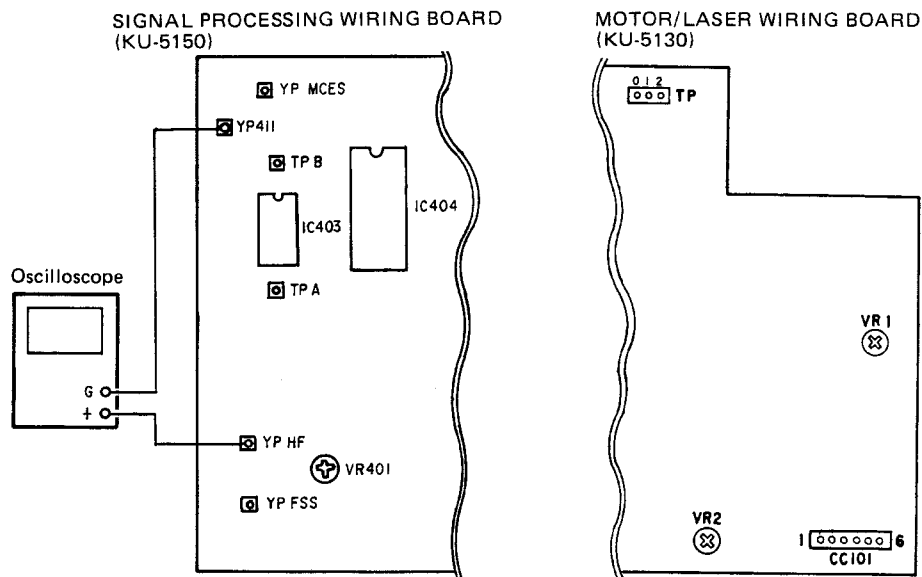

(FIG. 23)

WAVEFORM FOR (5)



EYE PATTERN FOR (11)

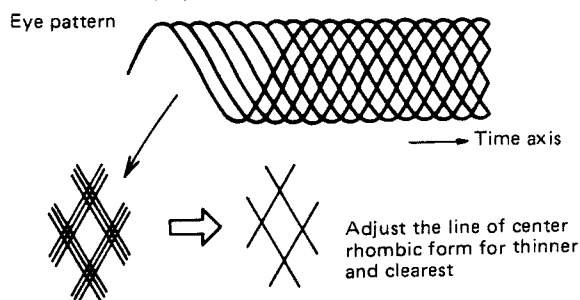

ADJUSTMENT POINT

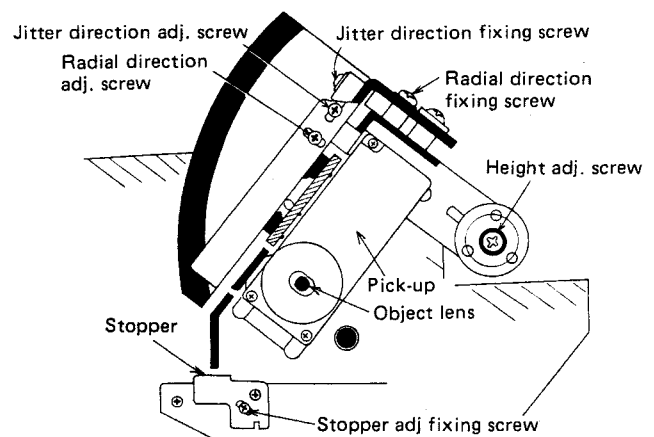

(FIG. 24)

7. Jitter direction fine adjustment. (Fig. 24, 25)

- (1) After the preadjustment, adjust the jitter direction adjustment screw to obtain the clearest eye pattern. Since adjustment range becomes broad, set at the center in the range where the eye pattern is stable.
- (2) Tighten the jitter direction fixing screw taking care that the eye pattern is not deteriorated.

8. Radial direction fine adjustment. (Fig. 24, 25)

- (1) Turn off Switches TSW and SSW on the adjustment

adaptor and connect the oscilloscope to TP5 on the servo wiring board.

- (2) Observe the oscilloscope and adjust the radial direction so that the noise amplitude becomes equal at the higher and lower sides.

If the noise level is so small that it is difficult to adjust, disconnect C40 (180pF) on the servo wiring board to increase the noise level. (Be sure to return C40 after adjustment.)

- (3) Tighten the radial direction fixing screw.

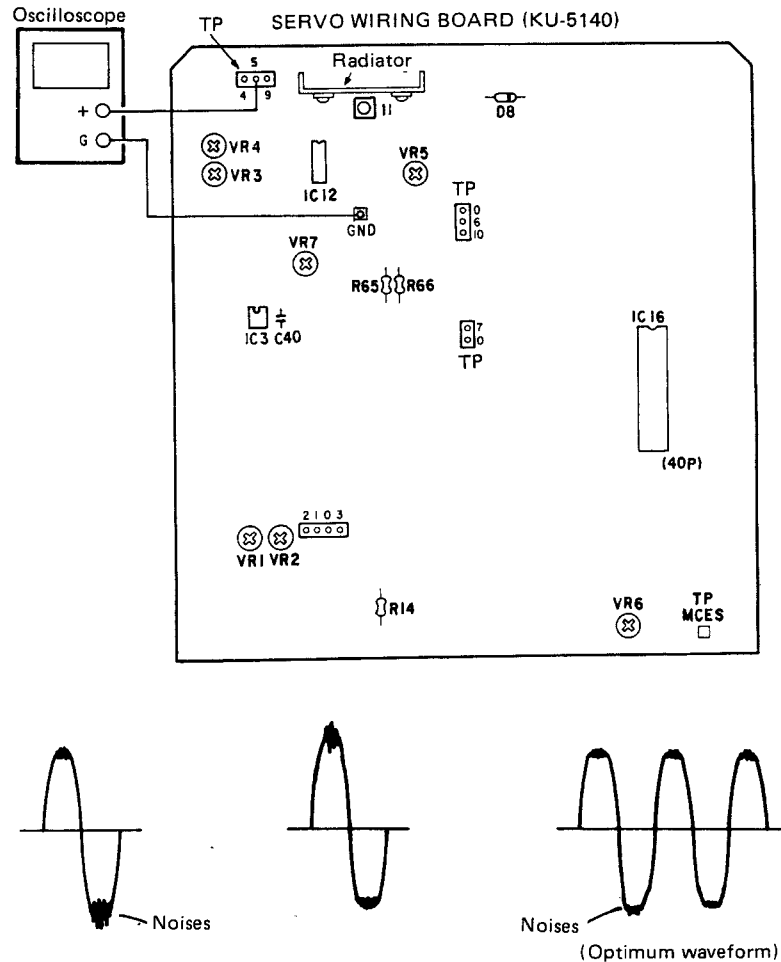

(FIG. 25)

9. Preadjustment of tracking amp off-set voltage. (Fig. 25)

- (1) Short-circuit pins ⑩ and ⑪ of IC12 on the servo wiring board. (or connect TP ⑪ to GND)
- (2) Turn on Switch SSW (TSW is off) and adjust VR7 so that the slide motor will not drift in either direction.

10. Adjustment of focus amp off-set voltage. (Fig. 23)

- (1) Connect the oscilloscope to YPHF (hot side), YP411 (GND) on the signal processing wiring board.
- (2) Turn on Switch TSW (SWs 3 to 8 are all on) on the adjustment adaptor.
- (3) Adjust VR1 on the motor wiring board to obtain the clearest eye pattern.

11. Height adjustment (Fig. 26)

- (1) Connect the oscilloscope to TP3 (TP-0 as GND) or connect across the R14 on the Servo wiring board.
- (2) Move the pick-up manually to bring the center of the pick-up lens at around innermost side of the 90mm disc edge.
- (3) Adjust the height adjustment screw so that the center of voltage waveform becomes $-50\text{mV} \pm 10\text{mV}$ on the oscilloscope.
- (4) Turn off all the switches on the adjustment adaptor and then turn off the main switch.

SERVO WIRING BOARD (KU-5140)

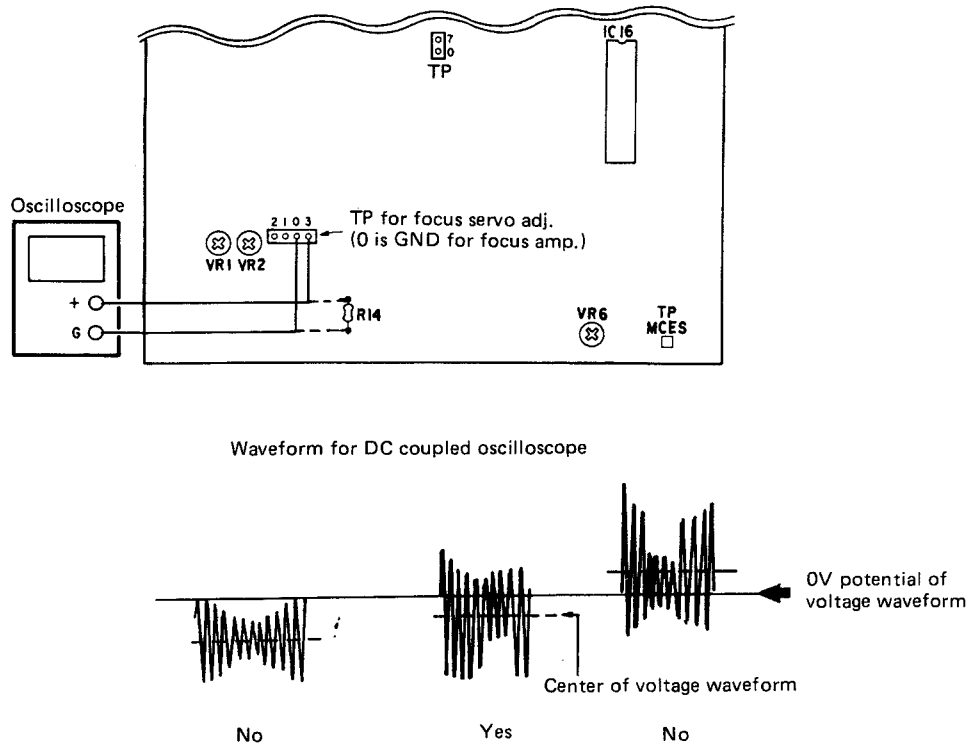

(FIG. 26)

ADJUSTMENT OF SERVO SYSTEM

1. Preparation. (Fig. 23)

- (1) Instruments: Adjustment adaptor
Adjustment disc (90 mm diam.)
Oscilloscope
Audio oscillator
- (2) Connect the oscilloscope to YPHF (hot side), YP411 (GND) on the signal processing wiring board.

2. Preadjustment of focus amp off-set voltage. (Turn on switches 3 to 5 and 8.) (Fig. 23)

- (1) Turn on the power.
- (2) Turn on switch SMSA1 on the adjustment adaptor.
- (3) Turn off SMSA1 and turn on switches SMSA2→, DDI→, FSWA consecutively. Make sure LED for FZC lights.
- (4) Turn on switch FSWB and check that the HSS LED lights. (Depending on the switching timing, the LED may fail to light. In such a case try the switch again. If the LED still does not light, proceed again from item 6 in the adjustment of mechanism unit.)
- (5) Turn off SMSA2 and turn on CSW. Then adjust VR1 on the motor wiring board so that the HF wave form becomes maximum.

3. Preadjustment of HF level. (Fig. 23)

- (1) Adjust VR401 on the signal processing wiring board so that the HF level becomes 2.5 Vp-p. (Test point YPHF)

4. Preadjustment of tracking amp off-set voltage. (Turn on switches 3 to 5, 7 and 8.) (Fig. 27)

- (1) Jumper Pin ⑩ and ⑪ of IC12 on the Servo wiring board. (Or short circuit between TP ⑪ and GND.)
- (2) Turn on switch SSW on the adjustment adaptor and adjust VR7 on the servo wiring board so that the pick-up will not drift in either direction. Make adjustment while the pick-up is in the middle. If there is any failure in adjustment, the pick-up will drift either outermost or innermost.
- (3) After the adjustments remove the short circuit between TP11 and GROUND.

SERVO WIRING BOARD (KU-5140)

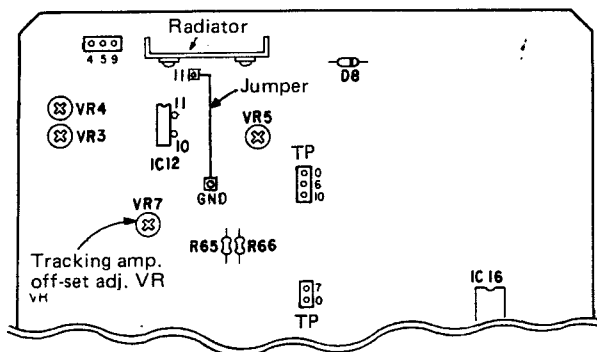

(FIG. 27)

5. Fine adjustment of focus amp off-set voltage. (Turn on switches 3 to 8.) (Fig. 23)

- (1) Turn on Switch TSW on the adjustment adaptor. (SWs 3 to 8: ON)
- (2) Adjust VR1 on the motor wiring board to obtain the clearest eye pattern on the scope.

6. Fine adjustment of HF level. (Turn on switches 3 to 8.) (Fig. 23)

- (1) Adjust VR401 on the signal processing wiring board so that the HF level becomes 2.5Vp-p. (Test point YPHF.)

7. Fine adjustment of tracking amp off-set voltage — same as item 4. (Turn on switches 3 to 5, 7 and 8.) (Fig. 27)

- (1) Jumper Pin ⑩ and ⑪ of IC12 on the servo wiring board. (Or short-circuit TP ⑪ to GND on the servo wiring board.)
- (2) Turn off Switch TSW on the adjustment adaptor and adjust VR7 on the servo wiring board so that the pick-up will not drift in either direction. (Make adjustment around the beginning of the 1st track.)
- (3) Remove the short-circuit between TP ⑪ and GND.

**8. Adjustment of focus servo gain.
(Turn on switches 3 to 8.) (Fig. 28)**

- (1) Connect the oscilloscope (X and Y inputs — Lissajous mode) to TPs 1 and 2 on the servo wiring board.
- (2) Connect the audio oscillator TP1 and apply 1.7 kHz, 30mVp-p sine wave.
- (3) Turn on switch TSW (SWs 3 to 8: ON) on the adjustment adaptor.
- (4) Adjust VRs 1 and 2 so that the X-Y display (Lissajous' figure) becomes symmetrical in respect to both X and Y axis.

SERVO WIRING BOARD (KU-5140)

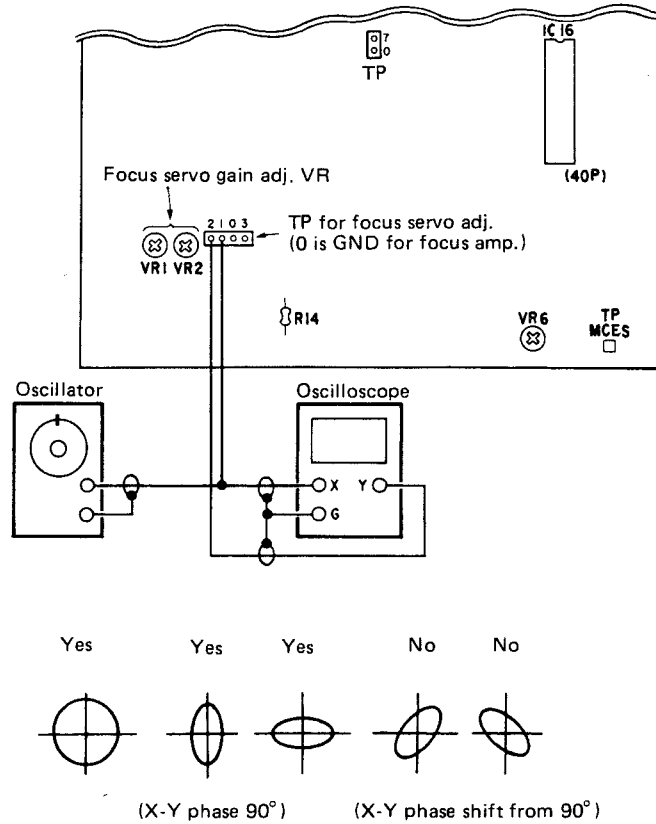

(FIG. 28)

**9. Adjustment of tracking servo gain.
(Turn on switches 3 to 8.) (Fig. 29)**

- (1) Connect the oscilloscope (X and Y inputs — Lissajous mode) to TPs 4 and 5 (TP 0: GND) on the servo wiring board.
- (2) Connect the audio oscillator to TP4 and apply 1.89 kHz, 0.2 Vp-p sine wave.
- (3) Adjust VRs 3 and 4 so that the Lissajous display becomes symmetrical in respect to both X and Y axis.

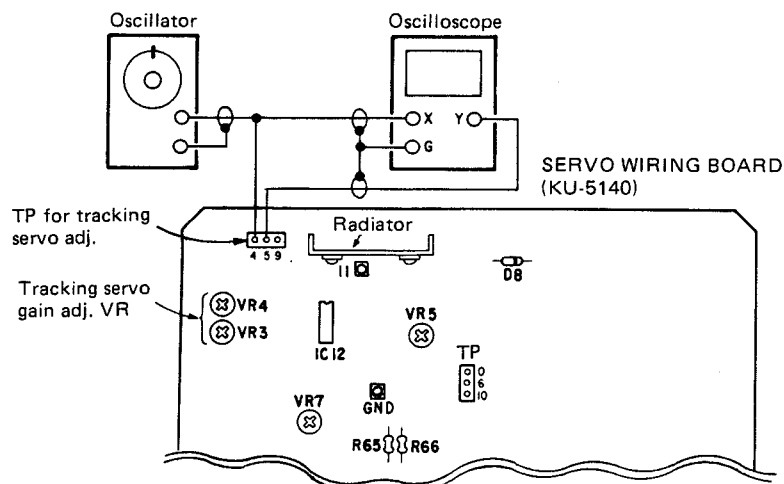

(FIG. 29)

10. Adjustment of pick-up height and confirmation of the mounting angle.
 (Turn on switches 3 to 8.) (Fig. 30)
 (Use the test disc Denon Technical CD138C39-7147C)

- (1) Connect the oscilloscope to TP3 on the servo wiring board (TP0: GND). (Or connect across the R14.)
- (2) Move the pick up at the beginning of first program.
- (3) Adjust the pick-up height adjustment screw so that the center of the focus actuator waveform comes -50mV $\pm 10\text{mV}$ on the scope.

- (4) Make sure that the shift of the center level is less than 120mV while the pick-up is moved from inside to outside.
 (If the shift of the center is more than 120mV , following causes can be presumed.)
 - Spindle motor is tilting.
 - The height of the mounting boss on NO. 187 Mech Base Ass'y is incorrect.
 - The shaft of No. 195 Rotor Ass'y is tilting.

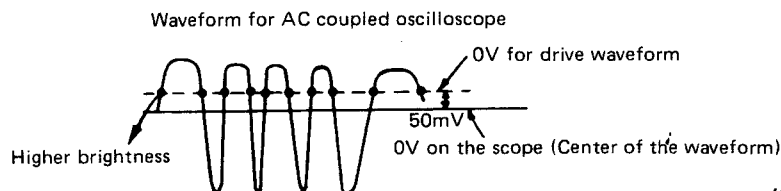
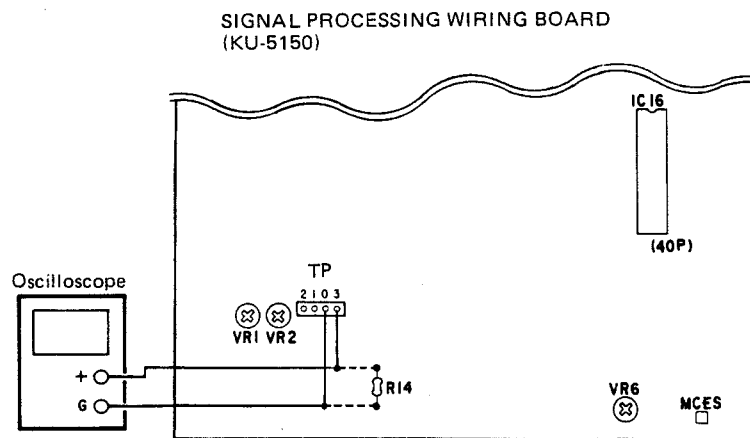

(FIG. 30)

11. Adjustment of the "kick voltage". (Fig. 31)

- (1) Turn off the main switch and remove the adjustment adaptor.
- (2) Connect ch1 (AC mode) of the oscilloscope to the anode of diode D8 on the servo wiring board.
- (3) Connect ch2 (DC mode) of the oscilloscope to the cross point of R65 and R66.
- (4) Set the oscilloscope trigger mode at ch2.
- (5) Return wires CB201 to the signal processing wiring

- (6) Play the middle of the program area of the adjustment disc and pause.
 Press the fast reverse button and adjust VR5 so that the HF envelope waveform becomes symmetrical.
- (7) Press the fast forward button and adjust VR5 again so that the HF envelope waveform becomes symmetrical.

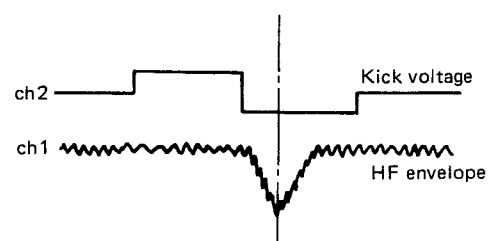
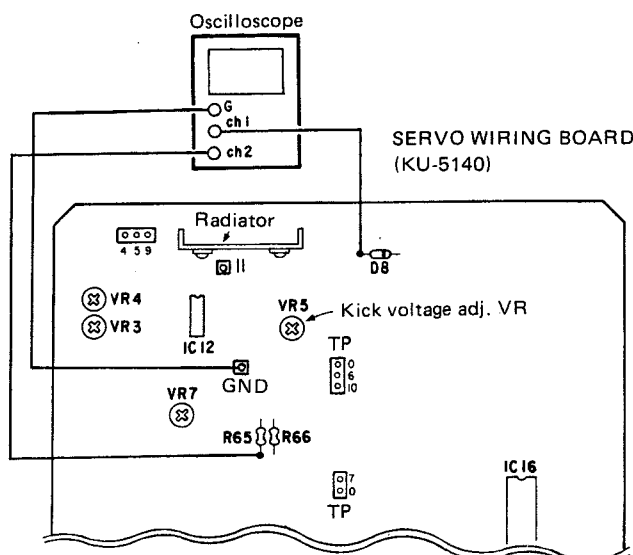

(FIG. 31)

(8) If the optimum points for Rev. and Fwd. do not coincide, set VR5 at the middle position.

NOTE: Triggering polarity V (\pm) should be changed for observing Rev. and Fwd. wave forms.

● **WAVEFORM EXAMPLES**

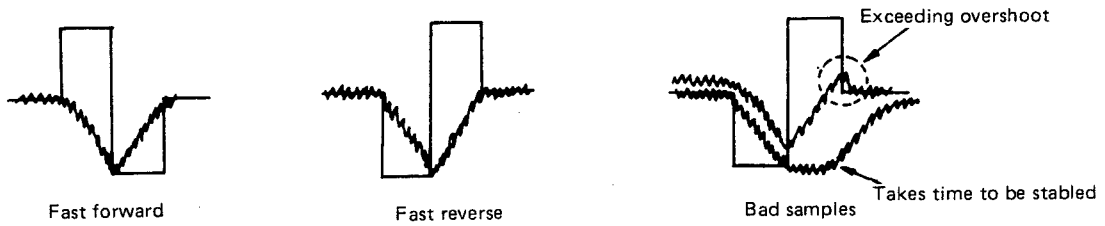

12. Adjustment of MCES. (Fig. 32)

(1) Connect the oscilloscope to TP-MCES (Square pin) on the servo wiring board.

(2) Move the pick-up in the middle of the program area (40 to 45 mm radius). Adjust VR6 so that the MCES duty becomes 50%.

SERVO WIRING BOARD (KU-5140)

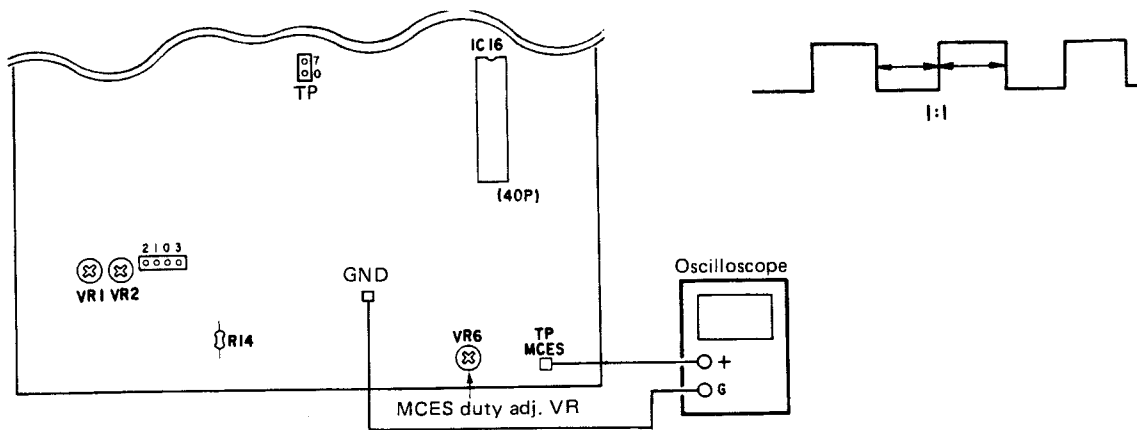

(FIG. 32)

Adjustment of signal processing circuit.

1. Adjustment of VCO oscillating frequency. (Fig. 33)

(1) Check that the HF level observed 2.5Vp-p at the TP YPHF. If not, adjust VR401 (refer to Fig. 23). Then connect a frequency counter to TP-A on the signal processing wiring board.

(2) Connect TP-B to YP411 (GND).

(3) Adjust L401 so that the frequency becomes 4.3218 MHz \pm 0.01 kHz on the counter.

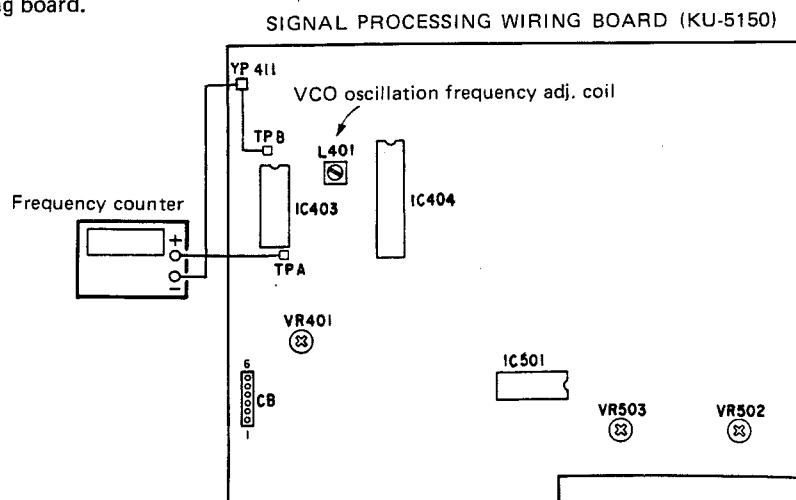

(FIG. 33)

2. Adjustment of audio output level.

- (1) Connect a 47k-ohm load resistor across the audio output terminals paralleled with an electronic volt meter.
- (2) Use the audio test disc Denon Technical CD138C39-7147) and playback 1kHz, 0dB signal.
- (3) Adjust VR502 for L-ch and VR503 for R-ch so that the audio output level becomes $2V \pm 0.3V$.

3. Distortion (In case IC501 is replaced)

Connect a distortion meter to the output terminals with the use of an external 20kHz Low Pass Filter. Play the 1kHz, -60dB signal band, and adjust VR501 so that the distortion becomes minimum.

If the minimum point cannot be obtained, set the slide switch SW1 at the opposite side and maintain the position.

SIGNAL PROCESS

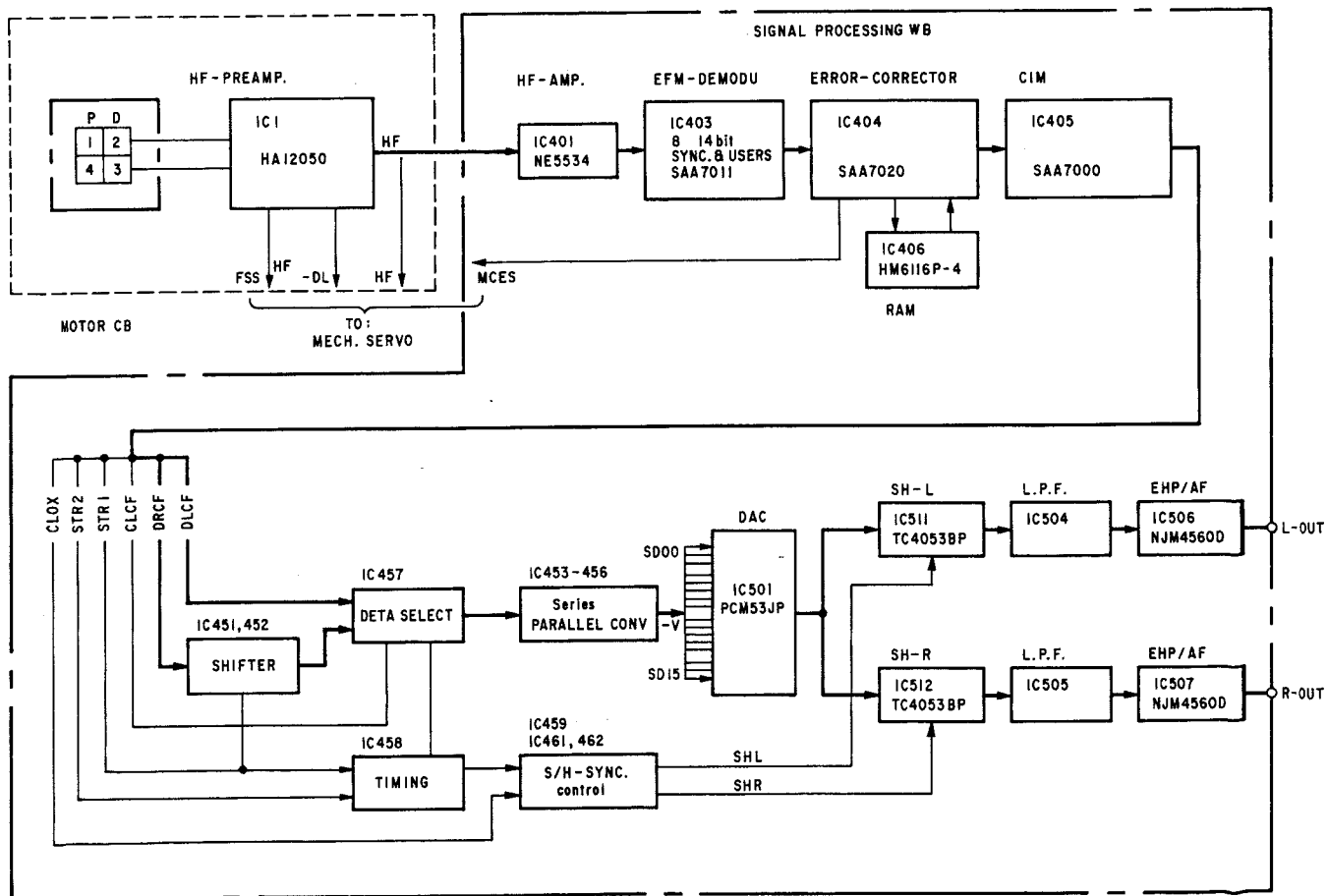

PARTS LIST OF P.W. BOARD

KU-5170/5171 POWER SOURCE UNIT

Ref. No.	Part No.	Part Name	Remarks
SEMICONDUCTOR GROUP			
Q907	2720053005	2SB647A	
Q901	2630286001	HA-178-05	
Q902	2630160004	μ PC7905H	
Q903,905	2630288009	HA-178-15	
Q904,906	2630200003	μ PC7915H	
D905,906	2760162024	1S1886	
D902,904,908	2760151006	1B2C-1	
D901,903,907	2760152005	1B2Z-1	
D909	2760303003	HZ6C1	
D910	2760314005	HZ-27-3	
RESISTOR GROUP			
*VR504	2118067001	V1620V30KA103	Variable resistor 10k Ω
CAPACITOR GROUP			
C590	2531027000	CK45F1H104Z	Ceramic 0.1 μ F 50V
C901	2538010007	CK45=2GA0103P	0.01 μ F 400V
C904	2544163032	CE04W1C103M	Electrolytic 10000 μ F 16V
C903	2546066014	CE04W1C332M	3300 μ F 16V
C911,920,921	2544086009	CE04W1E222=	2200 μ F 25V
C910	2546060023	CE04W1E332M	3300 μ F 25V
C907,908,914,915,924,925	2544172007	CE04W1H0R1	0.1 μ F 50V
C905,906,912,913,922,923	2544166042	CE04W1HR33	0.33 μ F 50V
C927	2544150003	CE04W1H100=	10 μ F 50V
C916	2544089022	CE04W1H101=	100 μ F 50V
C917	2544166000	CE04W1H221M	220 μ F 50V
OTHER PARTS GROUP			
F901	4770228008	SPACER (SK-16B)	
F901	4770229007	WASHER (YC-40B)	
F901	4170213105	POWER RADIATOR	
F901	2061015045	FUSE (0.315A)	E2, EA, EK
F901	2061025019	FUSE (0.63A)	E1, E3
F901	FEP-1287	FUSE HOLDER	E2, EA, EK
F901	EP-5870	FUSE HOLDER	E1, E3

KU-5241/5242 LINE FILTER UNIT

Ref. No.	Part No.	Part Name	Remarks
LF	Δ 2398019002	LINE FILTER COIL	
R1	Δ 2412164008	RD14B2E105J	1M Ω 1/4W
C1	Δ 2538010007	CK45=2GAC103P	0.01 μ F 400V
C2,3	Δ 2538004000	CK45=2BAC102P	0.001 μ F 125V (KU-5242 only)

WARNING:

Parts marked with Δ and/or shading have special characteristics important to safety. Be sure to use the specified parts for replacement.

KU-5160 KEY DISPLAY UNIT

Ref. No.	Part No.	Part Name	Remarks
SEMICONDUCTOR GROUP			
IC801	2620507004	HD6805V1-M	
IC802	2620516008	MSL915RS	
804			
IC803	2620512002	HD74LS154P	
IC805	2620517007	MSL917RS	
D801	2760049008	1S2076A	
~810			
CAPACITOR GROUP			
C801	2544147003	CE04W1H2R2=	2.2 μ F 50V
C803	2544130007	CE04W1A101=	100 μ F 10V
C802	2531024003	CK45F1H103Z	0.01 μ F 50V
C804	2533627000	CC45SL1H101J	100pF 50V
805			
C806	2531021006	CK45F1H102Z	0.001 μ F 50V
807			
OTHER PARTS GROUP			
S2~6	2123333005	TACT SW	
8~13			
15~26			
28			
X801	3990016017	FCR4.0M	
F801	3934012006	12BT02ZK	
	2123335005	MICRO SW	
CB801	2050190007	10P NH CON. BASE	
CB802	2050190081	8P NH CON. BASE	
CB803	2050190078	7P NH CON. BASE	
CB804	2050190065	6P NH CON. BASE	
CB805	2050190052	5P NH CON. BASE	
208			
CB806	2050190023	2P NH CON. BASE	
807			

• The carbon resistors rated at 1/4W are not listed herein.

• The carbon resistors rated at 1/4W are not listed herein.

KU-5140 SERVO UNIT

Ref. No.	Part No.	Part Name	Remarks
SEMICONDUCTOR GROUP			
IC10,11, 12,18	2620395009	TC-4066BP	
IC19,20	2620522005	TC-4053BP	
IC14	2620327006	HD74LS00P	
IC15	2620506005	HD74LS122P	
IC17	2620510004	HD74LS161P	
*IC16	2620518006	HD6805V1-S	
IC21	2620301006	HD14023BP	
*IC13	2620497004	TC-40H-004P	
*IC1,2,4,6, 8,9	2630276008	μ PC-4559-C	
*IC3,5	2630219007	TL-082-CP	
IC7	2630076004	HA17901P	
TR2	2710105002	2SA966(Y)	
*TR3,4	2710173005	2SA781K	
TR11,6	2710088006	2SA816(Y)	
TR7,9, 13~16, 18,20	2710102005	2SA1015(Y)	
TR1	2730201009	2SA2236(Y)	
TR5,10	2730177007	2SC1626(Y)	
TR8,12, 17,21,24	2730198002	2SC1815(Y)	
*D5,6,7,12	2760370007	1SS106	
D1~4, 8~11,13, 14	2760049008	1S2076	
RESISTOR GROUP			
R14,64,95	2440014010	RS14B3A5R6JNBF	Metal film 5.6 Ω 1W Variable resistor
VR3	EP-5462H3	SOLID VR (220 Ω)	220 Ω
VR1,4	EP-5462H9	SOLID VR (2.2K)	2.2k Ω
VR5	EP-5462H11	SOLID VR (4.7K)	4.7k Ω
VR2,6,7	EP-5462H13	SOLID VR (10K)	10k Ω
CAPACITOR GROUP			
C18,19,22, 23,37,63, 65,80,88, 93,98	2531024003	CK45F1H103Z	Ceramic 0.01 μ F 50V
C5,7,32, 34,35,48, 51,74, 75~77, 100,102, 104,106	2531027000	CK45F1H104Z	0.1 μ F 50V
C72	2533615009	CC45SL1H330J	33pF 50V
C15~17, 52,54	2533619005	CC45SL1H470J	47pF 50V
C53,55,1, 60,94,96	2533627000	CC45SL1H101J	100pF 50V
C40	2533633007	CC45SL1H181J	180pF 50V

Ref. No.	Part No.	Part Name	Remarks
C67	2533635005	CC45SL1H221J	220pF 50V
C11	2533643000	CC45SL1H471J	470pF 50V
C73	2533645008	CC45SL1H561J	560pF 50V Electrolytic
C97	2544130007	CE04W1A101=	100 μ F 10V
C99,101	2544131006	CE04W1A221=	220 μ F 10V
C27,28,91, 92	2544132005	CE04W1C100=	10 μ F 16V
C85	2549030005	CE04W=1E100M	10 μ F 25V
C8,9,31, 33,41,42, 47,50	2544139008	CE04W1E101=	100 μ F 25V
C103,105	2544029008	CE04W1E221=	220 μ F 25V
C78,79	2544140000	CE04W1V4R7=	4.7 μ F 35V
C45,46	2544172007	CE04W1H0R1	0.1 μ F 50V
C4,6,62, 64,95	2544146004	CE04W1H010=	1 μ F 50V Film
C20,21	2556099000	CQ09S1H102J	1000pF 50V
C66	2551120000	CQ93M1H102J	1000pF 50V
C70	2551120026	CQ93M1H152J	1500pF 50V
C26	2551120084	CQ93M1H472J	4700pF 50V
C49	2551120097	CQ93M1H562J	5600pF 50V
C25	2551121009	CQ93M1H682J	6800pF 50V
C39,61	2551121041	CQ93M1H153J	0.015 μ F 50V
C3,8,2	2551121054	CQ93M1H183J	0.018 μ F 50V
C71	2551121083	CQ93M1H333J	0.033 μ F 50V
C2	2551121096	CQ93M1H393J	0.039 μ F 50V
C81	2551122024	CQ93M1H683J	0.068 μ F 50V
C12,13,14, 68	2551122040	CQ93M1H104J	0.1 μ F 50V
C24,29	2551122066	CQ93M1H154J	0.15 μ F 50V
C69,83	2551122082	CQ93M1H224J	0.22 μ F 50V
C38	2551123010	CQ93M1H394J	0.39 μ F 50V
C30	2551123023	CQ93M1H474J	0.47 μ F 50V
OTHER PARTS GROUP			
CB608	2050190023	2P NH CON. BASE	
CB606, 607	2050190049	4P NH CON. BASE	
CB604, 605	2050190065	6P NH CON. BASE	
TP	2050190036	3P NH CON. BASE	
*CC603	2048128023	4P NH-SBN	
*CC609	2048130008	4P NH-SBN	
*CC601	2048132019	6P NH-SBN	
*CC602	2048133018	6P NH-SBN	

•The carbon resistors rated at 1/4W are not listed herein.

KU-5130 MOTOR & LASER UNIT

Ref. No.	Part No.	Part Name	Remarks
SEMICONDUCTOR GROUP			
*IC1	2630275009	HA12050	
*IC2	2630109007	TL-081-CP	
*IC3	2630276008	μ PC-4559-C	
*PC1	2690011009	ON1112	
TR3	2710105002	2SA966(Y)	
*TR5,7	2720068003	2SB711	
*TR4,6	2740091005	2SD721	
ZD1~3	2760051012	HZ-7B	
H1,2	2760303016	HL-300	
TR2	2710102005	2SA1015(Y)	
TR1,8	2730198002	2SC1815(Y)	
RESISTOR GROUP			
R9	2440031022	RS14B3A151JNBF	Metal film 150 Ω 1W
R32	2440140023	RS14B3E820JNBF	82 Ω 3W
R10	2440086006	RS14B3D101JNB	100 Ω 2W Variable resistor
VR3,4	EP-5462H3	SOLID VR (220 Ω)	220 Ω
VR1	EP-5462H9	SOLID VR (2.2K)	2.2k Ω
VR2	EP-5462H13	SOLID VR (10K)	10k Ω
VR5,6	EP-5462H17	SOLID VR (47K)	47k Ω
CAPACITOR GROUP			
C4	2533633007	CC45SL1H181J	Ceramic 180pF 50V
C1	2533635005	CC45SL1H221J	220pF 50V
C41,45, 46,73,74	2531027000	CK45F1H104Z	0.1 μ F 50V
C5	2544129005	CE04W1A470=	Electrolytic 47 μ F 10V
C8,11	2544130007	CE04W1A101=	100 μ F 10V
C6,7,10, 43,44,71, 72	2544146004	CE04W1H010=	1 μ F 50V
C2,3	2544147003	CE04W1H2R2=	2.2 μ F 50V Film
C9,12,21	2551121025	CQ93M1H103J	0.01 μ F 50V
OTHER PARTS GROUP			
*	2123335003	MICRO SW	
*	3468156014	COIL	
*CC102	2048128007	4P NH-SBN CONN	
*CC101	2048132006	6P NH-SBN CONN	
*CC103	2048133005	6P NH-SBN CONN	
TP1	2050190036	3P NH CONN BASE	
CB104	2050190049	4P NH CONN BASE	
*CB105	2050190094	9P NH CONN BASE	

KU-5150 SIG. PROC AUDIO

Ref. No.	Part No.	Part Name	Remarks
SEMICONDUCTOR GROUP			
IC201,202	2620326007	BA6109	
*IC404	2620490001	SAA-7020	
*IC405	2620491000	SAA-7000	
*IC406	2620296001	HM-6116P-4	
IC460	2620327006	HD74LS00P	
IC464	2628016005	HD74LS04P	
*IC407	2620514000	HD74LS74AP	
*IC458, 461,462	2620513001	HD74LS107AP	
*IC457	2620511003	HD74LS157P	
*IC459	2620510004	HD74LS161P	
*IC451 ~454	2620509002	HD74LS164P	
*IC455,456	2620508003	HD74LS273P	
IC511,512	2620522005	TC4053BP	
*IC501	2620515009	PCM-53JP-V	
*IC401,402	2630292008	NE5534N	
*IC403	2630279005	SAA-7011	
*IC408	2630287000	HA178M12P	
*IC502,503	2630285002	LF356N	
IC506,507	2630118001	NJM4560D	
IC508	2630295005	HA17903PS	
IC509,510	2630189001	M5218L	
*IC504,504	2630291009	L.P.F	
TR501, 502	2710102034	2SA1015(GR/Y)	
TR503	2730198015	2SC1815(BL)	
D503,504, 404~407, 409	2760049011	1S2076A	
D201	2760173042	HZ6B-1	
D403	2760236031	HZ5C-1	
D501,502	2760218017	HZ9A-2	
D202	2760255038	HZ12C-2	
D401,402	2760302004	SVC321SP-D2	
RESISTOR GROUP			
R201,202	2410137011	RD14B2H100JF	Carbon film 10 Ω 1/2W
R506,507	2440034016	RS14B3A271JNFB	Metal 270 Ω 1W Variable resistor
*VR501 VR401, 502,503	EP-5462H1 EP-5462H7	SOLID VR (100 Ω) SOLID VR (1K)	100 Ω 1k Ω
CAPACITOR GROUP			
C201,202, 207,208	2531024003	CK45F1H103Z	Ceramic 0.01 μ F 50V
C203~206	2531055069	CK45B1H101K	100pF 50V
C405,407,	2531025002	CK45F1H223Z	0.022 μ F 50V

• The carbon resistors rated at 1/4W are not listed herein.

Ref. No.	Part No.	Part Name	Remarks
410,412, 420,421, 422,427, 434~439, 442~444, 446,449, 461~472, 502,504, 506,508, 509,510, 511,528, 530,532, 534,536, 538,548, 550,553, 555,564, 549,551 566			
C584,585, 588,589	2531027000	CK45F1H104Z	0.1 μ F 50V
C431,432	2531008003	CK45B1H472K	4700pF 50V
C433	2531055027	CK45B1H821K	820pF 50V
C203~206, 209	2531027000	CK45F1H104Z	0.1 μ F 50V
C402	2533603008	CC45SL1H100D	10pF 50V
C440,441	2533613001	CC45SL1H270J	27pF 50V
C539,556	2533633007	CC45SL1H181J	180pF 50V Electrolytic
C428,448, 451,565	2544128006	CE04W1A220=	22 μ F 10V
C453	2544129005	CE04W1A470=	47 μ F 10V
C505,507	2544131006	CE04W1A221=	220 μ F 10V
C447	2544133004	CE04W1C220=	22 μ F 16V
C543,560, 580,581	2544136001	CE04W1C101=	100 μ F 16V
C571,573, 575,577	2544163032	CE04W1C102M	1000 μ F 16V
C517,519, 521,523, 571,573, 575,577	2544137000	CE04W1E330=	33 μ F 25V
C501,503	2544139008	CE04W1E101=	100 μ F 25V
C210,571, 573,575, 577	2544032008	CE04W1E102=	1000 μ F 25V
C531,533, 535,537, 552,554	2544146004	CE04W1H010=	1 μ F 50V
C526,542, 547,559	2551120026	CQ93M1H152J	Film 1500pF 50V
C425,430	2551120042	CQ93M1H222J	2200pF 50V
C403	2551121025	CQ93M1H103J	0.01 μ F 50V
C426,429	2551121067	CQ93M1H223J	0.022 μ F 50V

Ref. No.	Part No.	Part Name	Remarks
C401	2551122037	CQ93M1H823J	0.082 μ F 50V
C423,424	2551122040	CQ93M1H104J	0.1 μ F 50V
C452	2551123010	CQ93M1H394J	0.39 μ F 50V
C582,583	2556111001	CQ09S1H332J	0.0033 μ F 50V
C556	2556161019	CQ09S1H470J	47pF 50V
C586,587	2561026000	CF93A2B105K	1 μ F 125V
OTHER PARTS GROUP			
*X401	3998049002	X'TAL	
*L401	2310826008	OSC COIL	
*L501~504	2310828006	INDUCTOR	
*L505,506	2310829005	RESONATOR	
L507,508	2148004005	L22.M	
	2048123002	2P RCA PIN JACK	
CB201, 203	2050190023	2P NH CON. BASE	
CB202	2050190036	3P NH CON. BASE	
CB404, 406	2050190049	4P NH CON. BASE	
CB204	2050190052	5P NH CON. BASE	
CB401	2050190065	6P NH CON. BASE	
~403,407			
TP401	2050190078	7P NH CON. BASE	
CB405	2050190081	8P NH CON. BASE	
CC410	2037646008	4P NH-SCB CON	

● The carbon resistors rated at 1/4W are not listed herein.

KU-5270 CUE, REV KEY UNIT

Ref. No.	Part No.	Part Name	Remarks
SEMICONDUCTOR GROUP			
IC1	2620538002	HD74LS27P	
IC2	2620537003	HD74LS123P	
IC3	2620419008	HD14053BP	
IC4	2620536004	TL7705CP-B	
IC5	2620506005	HD74LS122P	
D1	2760370007	1SS106	
CAPACITOR GROUP			
C1,3	2544132005	CE04W1C100=	10 μ F 16V
C2,4	2531027000	CK45F1H104Z	0.1 μ F 50V
C5	2544011003	CE04W1A221=	220 μ F 10V
C6	2544147003	CE04W1H2R2=	2.2 μ F 50V
OTHER PARTS GROUP			
CB1	2050190052	5P NH CONN. BASE	
CB2	2050190036	3P NH CONN. BASE	
CB3,4	2050190023	2P NH CONN. BASE	

● The carbon resistors rated at 1/4W are not listed herein.

PARTS LIST OF EXPLODED VIEW

Ref. No.	Part No.	Part Name	Remarks
1	1058100003	BACK PANEL	E2
	1058110006	BACK PANEL	E3
	1058104009	BACK PANEL	E1
	1058105008	BACK PANEL	EA
	1058106007	BACK PANEL	EK
△ 2	2062002031	AC CORD	E2
	2062019008	AC CORD	E3
	2006031026	AC CORD	E1
	2006019307	AC CORD	EA
	2062024006	AC CORD	EK
△ 3	4450020005	CORD BUSH	E2,EK
	MD-3802	CORD BUSH	E3,E1
	MD-2982H	CORD BUSH	EA
4	KU-51502	SIG. PROC. UNIT 2	
5	4770064107	FIXING SCREW	
6	4121496104	TRANS SUPPORT	
△ 7	2334092203	POWER TRANS.	E2,EA,EK
	2334091000	POWER TRANS.	E3
	2334093008	POWER TRANS.	E1
8	4734454038	4x8 CTTS	
9	4150269001	INSULATING SHEET	
10	4121492108	SIDE CHASSIS (L)	
11	4121494300	CENTER CHASSIS	
12	4121594006	PCB BRACKET	
13	4121493000	SIDE CHASSIS (R)	
14	4121491109	FRONT CHASSIS	
15	4150275105	INSULATING SHEET (A)	
16	4770234005	INSULATING WASHER	
17	4121495008	H/P BRACKET	
18	4730354019	3x8 CBRTS (2)	
19	4121488109	POWER SW BRACKET	
△ 20	2123336002	POWER SW	
△ 21	2568009017	CF99B2BAC223M	
22	4700009006	3x6 CPS (SW)	
23	4690025006	POWER SW CONNECTOR	
24	4170213105	POWER RADIATOR	
25	4124970006	PCB SUPPORT	
26	4713304015	3x8 CBS	
27	KU-5170	POWER SOURCE UNIT	
28	KU-5140	SERVO UNIT	
29	4770063108	INSULATING WASHER	
30	4150261009	PCB HING	
31	KU-5150	SIG. PROC. UNIT	
32	1441159506	FRONT PANEL ASS	
33	1130507207	KNOB (A) ASS	
34	1130508206	KNOB (B) ASS	
35	1130508219	KNOB (B) ASS	
36	1130508222	KNOB (B) ASS	
37	1130508235	KNOB (B) ASS	
38	1130508248	KNOB (B) ASS	
39	1130508251	KNOB (B) ASS	
40	4630365108	KNOB SPRING	
41	1130496101	POWER KNOB ASS	
42	4630363003	POWER SW SPRING	

Ref. No.	Part No.	Part Name	Remarks
43	1460639308	KNOB FRAME ASS	
44	4730306012	3x12 CBRTS (1)	
45	1430341008	FILTER	
46	1460634303	DISPLAY PANEL	
47	4730305013	3x10 CBRTS (1)	
48	KU-5160	KEY DISPLAY UNIT	
49	KU-5241	LINE FILTER UNIT	E3 only
	KU-5242	LINE FILTER UNIT	
50	KU-5270	CUE, REV KEY UNIT	
51	1050575102	BOTTOM COVER	
52	1040109009	FOOT	
53	4770052012	FIX SCREW	
54	1020171112	TOP COVER	
	1020171109	TOP COVER	E3 only
55	4734801005	4x8 CTTS	
56	1011532100	WOOD BOARD (L)	E3 only
57	1011533109	WOOD BOARD (R)	E3 only
58	4751006016	5W	E3 only
59	4752004004	4 SW	E3 only
60	4734456036	4x12 CTTS	
61	4734460035	4x20 CTTS	E3 only
62	1120434005	KNOB	
63	KU-51702	POWER SOURCE UNIT	
64	4350083207	CONNECTING ROD	
65	1240032015	FELT SHEET	
66	1220064045	SPACER	
67	1220108008	SPACER	
68	4770229007	WASHER	
69	4618157008	RUBBER SHEET	
70	4150277006	SHIELD PLATE	
71	4610154025	CUSHION	
△ 72	2120186019	VOLTAGE SELECTOR	E1 only
73	4713304031	3x8 CBS	E1 only

Remarks symbols in the parts list refer to the following countries and areas.

- EA: Australia
- EK: United Kingdom
- E1: Multiple voltage model
- E2: European continent
- E3: North America

WARNING:

Parts marked with △ and/or shading have special characteristics important to safety. Be sure to use the specified parts for replacement.

EXPLODED VIEW OF CABINET

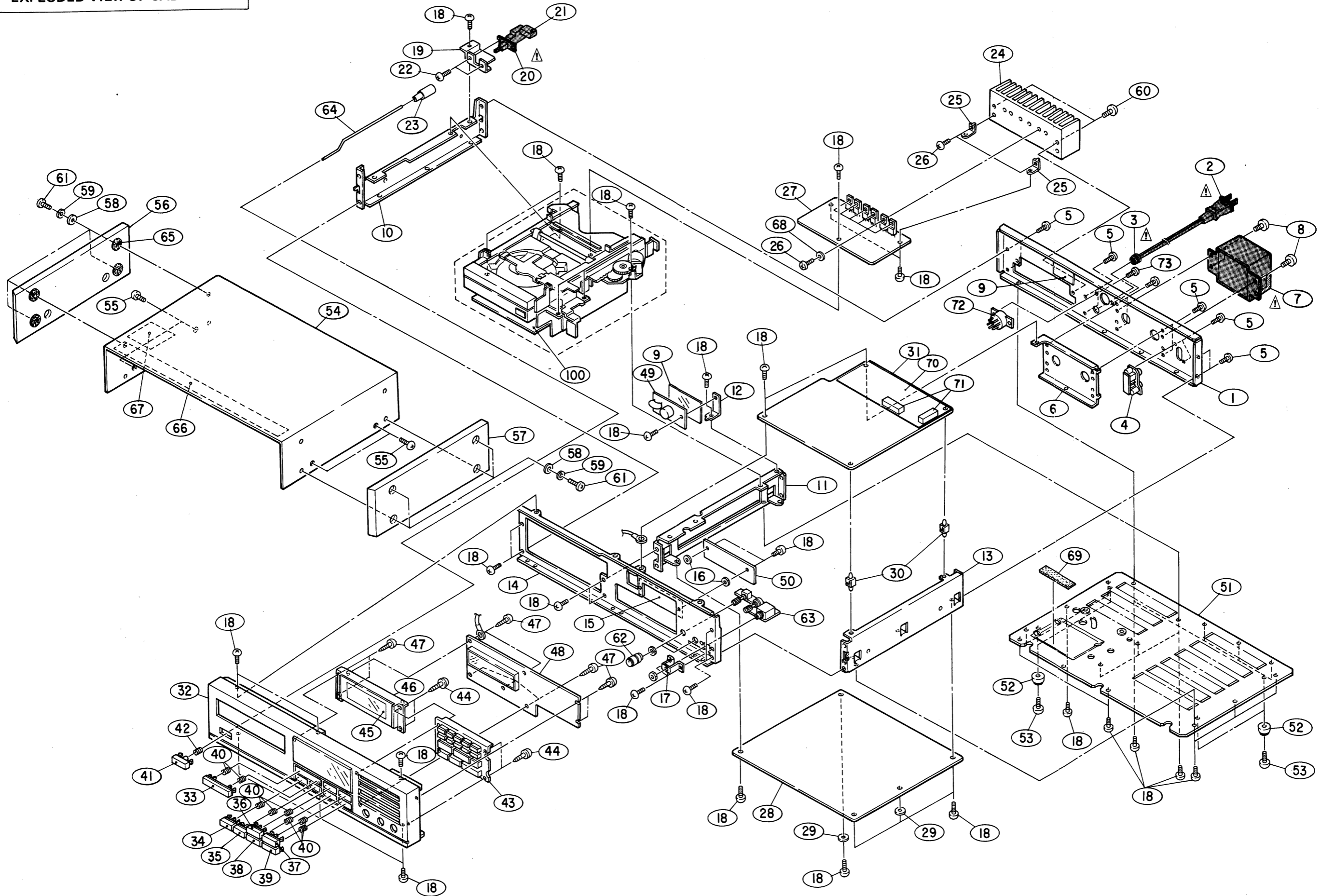

PARTS LIST OF MECHANISM UNIT

Ref. No.	Part No.	Part Name	Remarks
*101	4110397201	BASE CHASSIS	
*102	4610204001	ROD SUPPORT	
*103	4121454007	DISK DOWN BKT	
*104	4330354105	ARM BRACKET	
105	4761003009	3E RING	
*106	4121451107	MOTOR BRACKET (B)	
*107	2170120106	MOTOR (B)	
108	4730354019	3x8 CBRTS (2)	
109	4700001004	2.6x4 CPS SW	
*110	4240070100	GEAR (A)	
*111	4240071109	GEAR (B)	
112	4761004008	4E RING	
*113	4238033007	LOADING BELT	
*114	4460015000	GUIDE RAIL (R)	
*115	4121633006	STOPPER (R)	
116	4711301010	3x4 CPS	
*117	4610206009	RUBBER SHEET	
118	4700007008	3x4 CPS SW	
*119	4460016106	GUIDE RAIL (L)	
120	4610209009	RUBBER SHEET	
*121	4121460004	STOPPER (L)	
*122	4310132101	RACK (A)	
*123	4310133003	RACK SUPPORT	
124	4713303058	3x6 CBS	
*125	4310137203	LOADING RAIL (L)	
*126	4310135001	TRAY UPPER	
*127	4121461304	TRAY GUIDE BKT (R)	
*128	4630357006	TRAY UPPER SPRING	
129	4712303017	3x6 CFS	
*130	4490022005	LOCK LEVER	
*131	4310136000	RACK (B)	
*132	4630358005	RACK SPRING	
*133	4220272009	RACK SCREW	
134	4770201009	3x4 TT SCREW	
*135	4310134206	LOADING RAIL (R)	
*136	4121462303	TRAY GUIDE BKT (L)	
137	4713302017	3x5 CBS	
*138	4121489101	RETAINER STOPPER (L)	
*139	4121490003	RETAINER STOPPER (R)	
*140	4310139201	DISK BASE	
*141	4220270001	UP DOWN SHAFT	
*142	4410403303	DISC GUIDE	
143	4712304032	3x8 CFS	
144	4712303017	3x6 CFS	
*145	4200064208	TRAY DOWN SHAFT	
*146	4121463108	LOADING STAY	
*147	4460017008	LOADING PANEL	
*148	1460638008	KNOB GUIDE	
149	4732354033	3x8 CFTS	
*150	1130499205	OPEN/CLOSE KNOB	
*151	4690026018	SPACER	
*152	4310140009	ROLLER ASS	
*153	4121465009	LOADING STOPPER (R)	

Ref. No.	Part No.	Part Name	Remarks
*154	4610206012	RUBBER SHEET	
*155	4121464000	LOADING STOPPER (L)	
*156	4690024007	STOPPER RUBBER	
*157	4121602008	LOCK SUPPORT ASS	
*158	4200062006	LOCK ARM ASS	
159	4761001001	2E RING	
*160	4121472005	MOTOR BRACKET (A)	
*161	4240070100	GEAR (A)	
*162	4240072108	WORM WHEEL	
*163	2170117009	DC MOTOR (ARM)	
*164	4248025403	WORM GEAR	
*165	4610203109	MICRO SW SPRING	
*166	4121632007	STOPPER (L)	
*167	4121485102	CLAMP BRACKET (A)	
*168	4630361005	CLAMP SPRING (A)	
*169	4210259003	CLAMP PRESS	
*170	4210257102	CLAMPER	
171	4752003005	3 SW	
*172	4430300004	CLAMP COVER	
*173	4770096007	PUSH RIVET	
*174	4121469102	CLAMP BRACKET (B)	
*175	4630362004	CLAMP SPRING (B)	
*177	4121471103	CLAMP BRACKET (D)	
*178	4220266002	CLAMP SHAFT (A)	
179	4770232007	WASHER	
181	4744300004	2.6x4 BSS (A)	
183	4121576202	BLIND PLATE	
*186	4428113300	MECH PLATE ASS'Y	
*187	4468115106	MECH BASE ASS'Y	
*188	4158054205	SHEET	
*189	4258052000	THRUST WASHER	
*190	KU-5130	MOTOR & LASER UNIT	
*191	4428161006	STOPPER (1)	
*192	4638827004	SPRING PLATE	
*194	4438785207	MOTOR HOUSING ASS'Y	
*195	4218388002	ROTOR ASS'Y	
*197	4218391206	TURNTABLE	
198	4770032003	3x6 SS	
*199	4638632008	SPRING	
*200	4218392108	CENTER CAP	
201	4751121108	SLIT WASHER	
*202	4338264501	PULLEY ARM	
*203	2178093002	DC MICRO MOTOR	
204	4713102042	2x5 CBS	
*205	4218393107	PULLEY ASS'Y	
*206	4238027000	BELT	
*207	4428115308	PU SUPPORT (A)	
*208	4148199002	SHUTTER	
*210	4428117102	PU SUPPORT (B)	
*211	4638633002	SPRING	
*212	4638827004	SPRING PLATE	
213	4700015016	3x20 CPS W	
214	4700009019	3x6 CPS W	

Ref. No.	Part No.	Part Name	Remarks
215	4700009006	3x6 CPS (SW)	
*216	4998008000	OPTICAL PICKUP	
*217	4338262202	PU ARM ASS'Y	
*218	4428150004	STOPPER	
*219	4258051001	THRUST SCREW	
*220	4128836000	LOCK PLATE	
*221	4338277103	LOCK ARM ASS'Y	
*222	4338278102	LOCK LEVER ASS'Y	
*223	4638830004	TWIST SPRING	
*226	4618142107	FLAT SPRING	
*227	4638254004	SPRING	
*228	4628038104	RUBBER BUSH	
*230	4438804007	COLLAR	
231	4700013018	3x14 CPS W	
*232	4121453105	STAY	
*233	4121474100	SLIDE SW BRACKET	
*234	KU-51602	KEY-DISPLAY UNIT	
235	4770116039	2.6x10 T.T SCREW	
236	4730353010	3x6 CBRTS	
237	4737002005	3x6 CBTS(S)	
*238	4121456102	SLIDE SW BRACKET	
*239	KU-51603	KEY-DISPLAY UNIT	
*240	KU-51604	KEY-DISPLAY UNIT	
*241	KU-51605	KEY-DISPLAY UNIT	
*242	1460628005	LOADING PLATE	
245	4737002005	3x6 CTBS (S)	
246	4713303016	3x6 CBS	
247	4438158041	COLLAR	
248	4751006003	5W	
249	4751003006	3W	
250	4713306013	3x12 CBS	
*251	4258011009	STEEL BALL	
*252	4428112000	ARM STOPPER	
*253	4770063108	INSULATING WASHER	
*254	KU-51301	MOTOR/LASER UNIT	
*255	KU-51302	MOTOR/LASER UNIT	

PACKING & ACCESSORIES GROUP

Ref. No.	Part No.	Part Name	Remarks
	5018341002	CARTON CASE	
	5038059002	CUSHION ASS	
	5030416009	CUSHION ASS	E3 only
	5018359007	OUTER CARTON	
	5030245005	CORNER PAD	
	5050061007	ENVELOPE	
	5118278004	INST. MANUAL	
	2048121004	2P PIN CORD	
	2033667007	PLUG ADAPTER	E1 only

EXPLODED VIEW OF MECHANISM UNIT

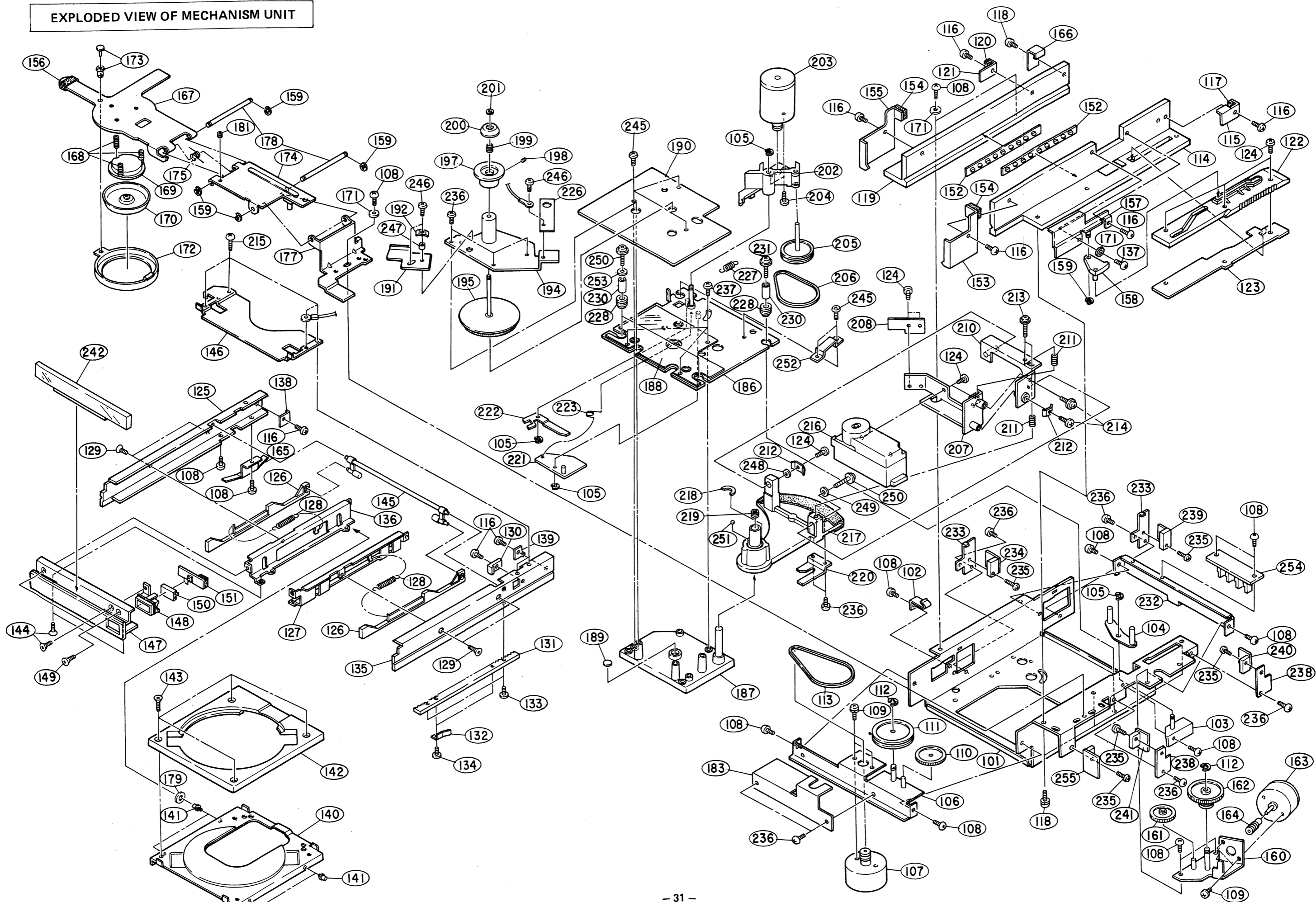

P.W. BOARD

KU-5150 SIG. PROCESSING AUDIO UNIT

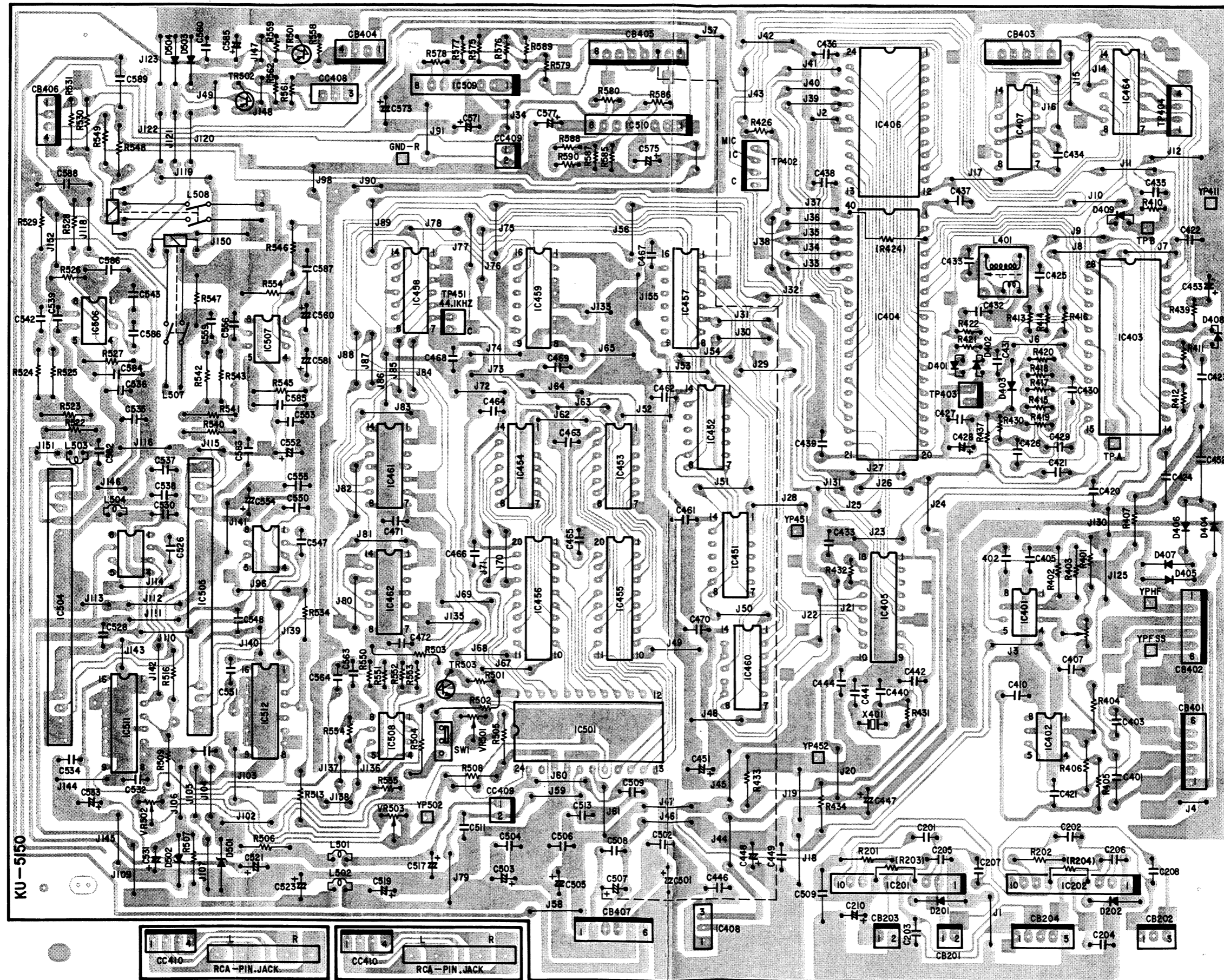

KU-5140 SERVO UNIT

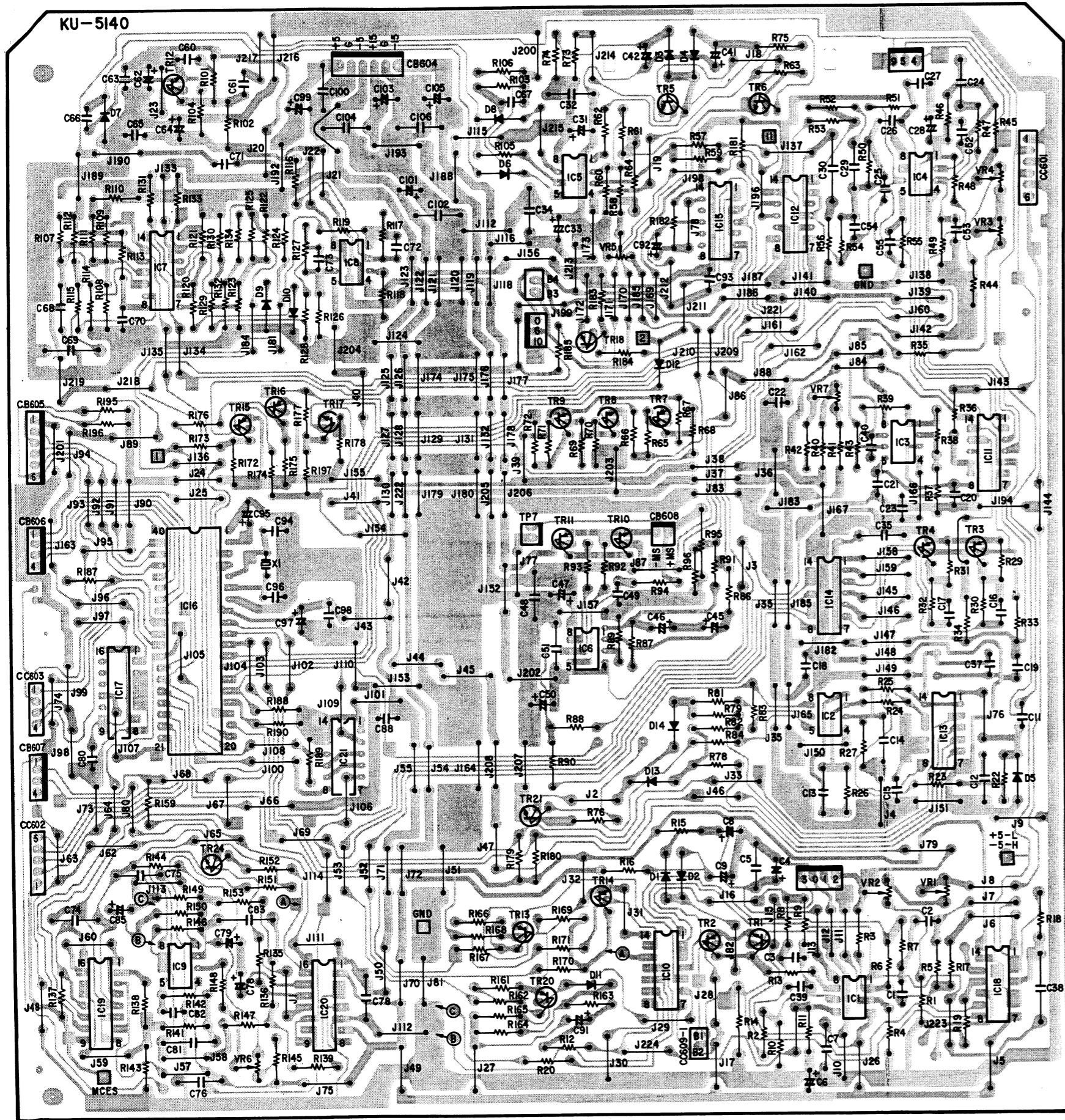

KU-5270 CUE, REV. KEY UNIT

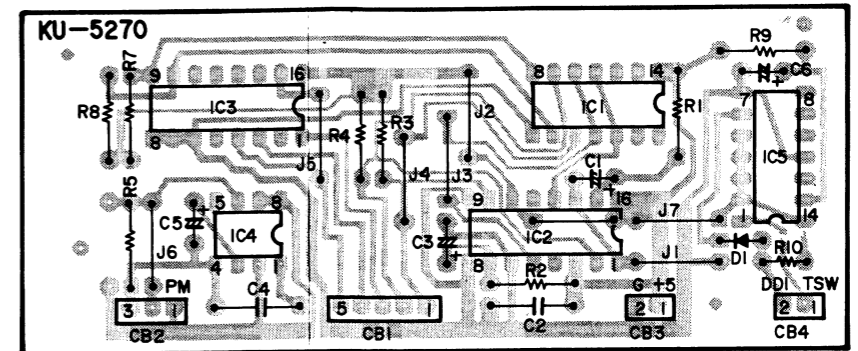

KU-5241/5242 LINE FILTER UNIT

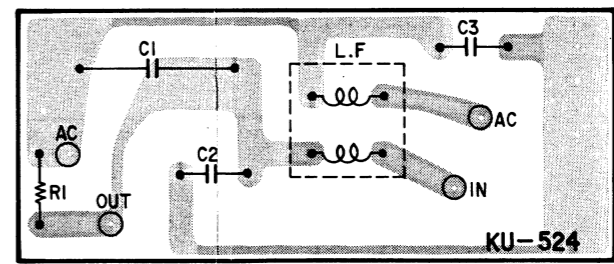

KU-5160 KEY DISPLAY UNIT

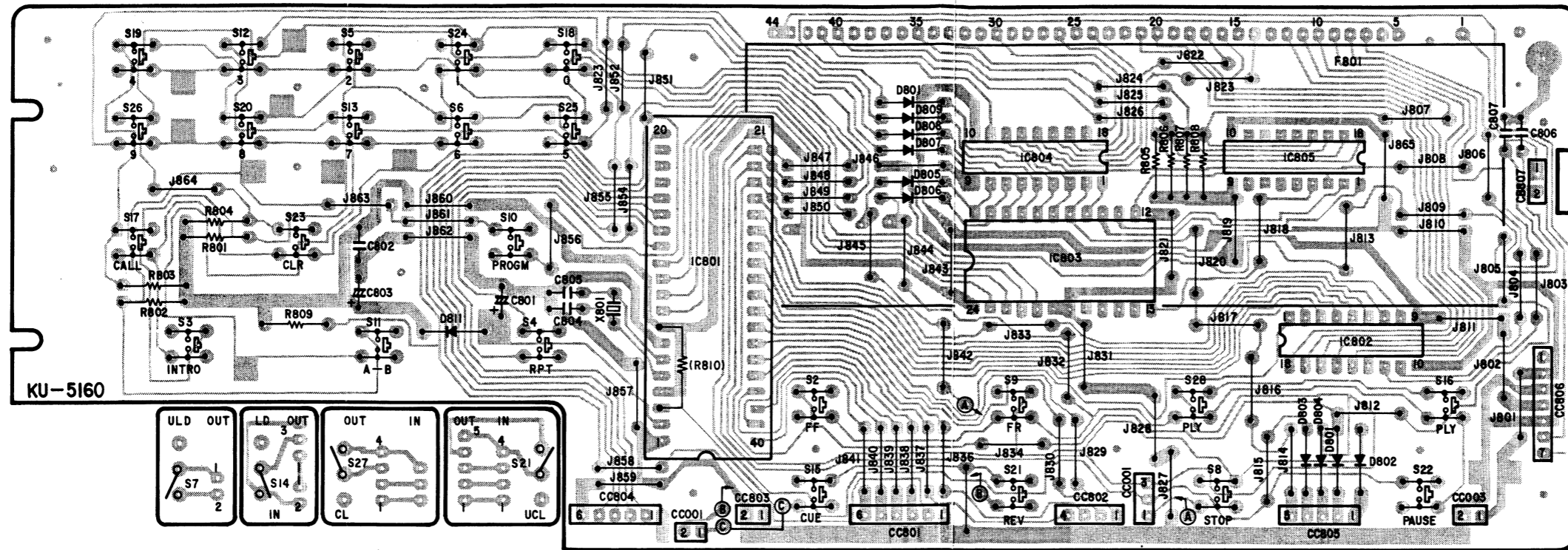

KU-5130 MOTOR & LASER UNIT

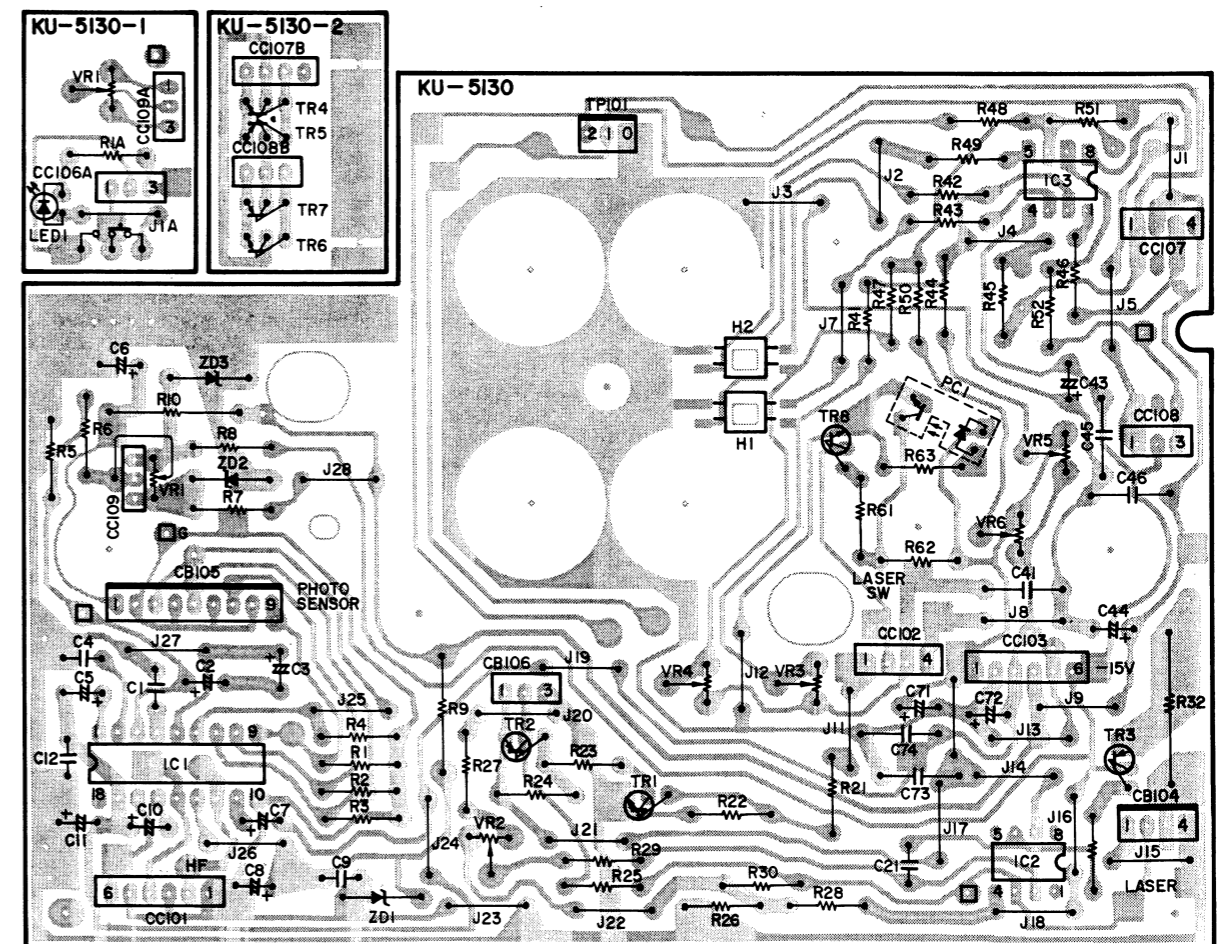

KU-5170/5171 POWER SOURCE UNIT

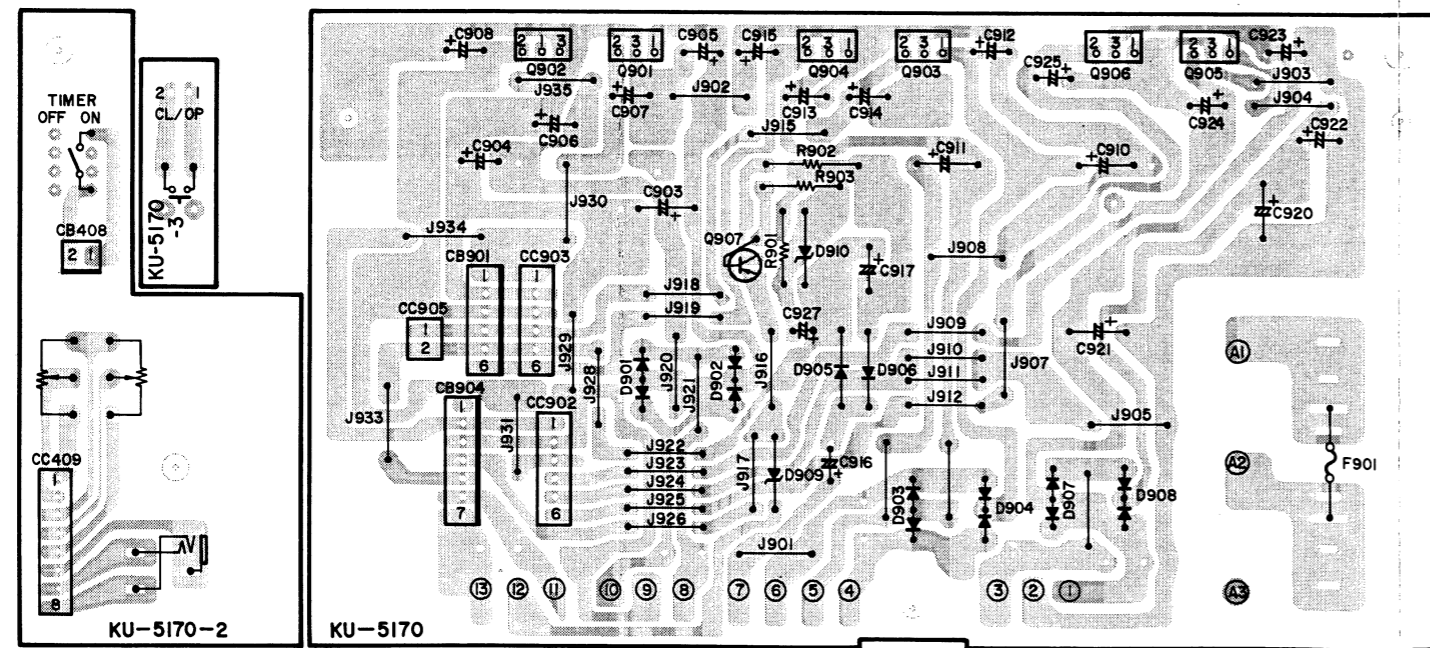

FUNCTION TABLE OF CPU TERMINAL

SERVO CPU IC-16 (HD6805V1-S)

PIN NO.	PORT	SYMBOL	IN/OUT	FUNCTION
1		Vss		Power source ground
2		RES		Reset
3		INT		EXTERNAL INTERRUPT
4		Vcc		Power source positive
5		XTAL	IN	Crystal oscillation
6		EXTAL	OUT	Crystal oscillation
7		NUM		Timer
8		TIMER		Timer
9	PC0	FSP	OUT	Focus search pulse
10	PC1	DDI	OUT	Defect detector inhibit
11	PC2	SMR	OUT	Slide motor reverse
12	PC3	SMF	OUT	Slide motor forward
13	PC4	KP-	OUT	Kick pulse negative
14	PC5	KP+	OUT	Kick pulse positive
15	PC6	SMFS	OUT	Slide motor fast status (H: slow, L: fast)
16	PC7	SMSA	OUT	Spindle motor start (L: full torque, PWM: CLV)
17	PD7	STBIN	IN	Standby (acknowledge) in
18	PD6	ISW	IN	Inmost switch
19	PD5	HSS	IN	HF signal status
20	PD4	FZC	IN	Focus zero cross
21	PD3	TC	IN	Track cross
22	PD2	SWCL	IN	Sub-words (S,Q) clock
23	PD1	SUBS	IN	Sub sync data
24	PD0	SUBQ	IN	Sub Q data
25	PB0	FSWA	OUT	Focus servo switch A
26	PB1	FSWB	OUT	Focus servo switch B
27	PB2	SSW	OUT	Slide motor servo switch
28	PB3	TSW	OUT	Tracking servo switch
29	PB4	CSW	OUT	CLV servo switch
30	PB5	EMP	OUT	De-emphasis (H: off, L: on)
31	PB6	MUTE	OUT	Mute (H: on, L: off)
32	PB7	LASW	OUT	Laser switch
33	PA0	DB0	IN/OUT	Data bus bit 0
34	PA1	DB1	IN/OUT	Data bus bit 1
35	PA2	DB2	IN/OUT	Data bus bit 2
36	PA3	DB3	IN/OUT	Data bus bit 3
37	PA4	MCK	IN/OUT	Move (data transfer) clock
38	PA5	STBOUT	OUT	Standby (acknowledge) out
39	PA6	IRQA	OUT	Interrupt request
40	PA7			

SERVO CPU
IC-16 (HD-6805V1-S)

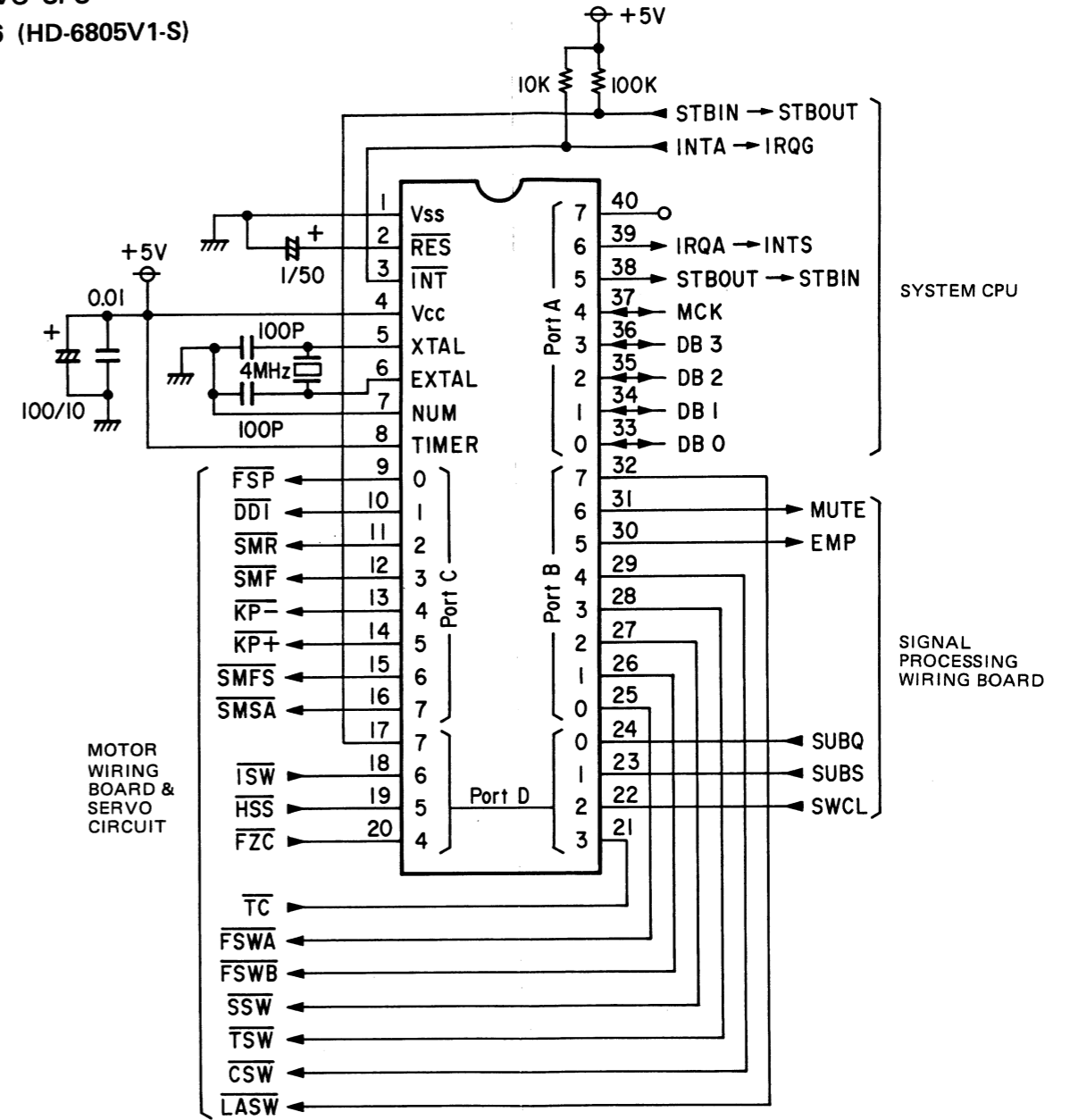

SYSTEM CPU IC801 (HD-6805V1-M)

PIN NO.	PORT	SYMBOL	IN/OUT	FUNCTION
1		Vss		Power source ground
2		RES		Reset
3		INT		EXTERNAL INTERRUPT
4		Vcc		Power source positive
5		XTAL	IN	Crystal oscillator
6		EXTAL	OUT	Crystal oscillator
7		NUM		
8		TIMER		Timer
9	PC0	S0	OUT	Key and display scan bit 0
10	PC1	S1	OUT	Key and display scan bit 1
11	PC2	S2	OUT	Key and display scan bit 2
12	PC3	S3	OUT	Key and display scan bit 3
13	PC4	LMR	OUT	Loading motor R (open)
14	PC5	LML	OUT	Loading motor L (close)
15	PC6	CMR	OUT	Clamp motor R (up)
16	PC7	CML	OUT	Clamp motor L (down)
17	PD7			
18	PD6			
19	PD5			
20	PD4	TSW	IN	Timer switch input
21	PD3	R3	IN	Key return bit 3
22	PD2	R2	IN	Key return bit 2
23	PD1	R1	IN	Key return bit 1
24	PD0	R0	IN	Key return bit 0
25	PB0	D0(a)	OUT	Display segment data bit 0
26	PB1	D1(b)	OUT	Display segment data bit 1
27	PB2	D2(c)	OUT	Display segment data bit 2
28	PB3	D3(d)	OUT	Display segment data bit 3
29	PB4	D4(e)	OUT	Display segment data bit 4
30	PB5	D5(f)	OUT	Display segment data bit 5
31	PB6	D6(g)	OUT	Display segment data bit 6
32	PB7	D7(h)	OUT	Display segment data bit 7
33	PA0	DB0	IN/OUT	Data bus bit 0
34	PA1	DB1	IN/OUT	Data bus bit 1
35	PA2	DB2	IN/OUT	Data bus bit 2
36	PA3	DB3	IN/OUT	Data bus bit 3
37	PA4	MCK	IN/OUT	Move (data transfer) clock
38	PA5	STBIN	IN	Standby (acknowledge) in
39	PA6	IRQS	OUT	Interrupt request
40	PA7	STBOUT	OUT	Standby (acknowledge) out

SYSTEM CPU
IC801 (HD6805V1-M)

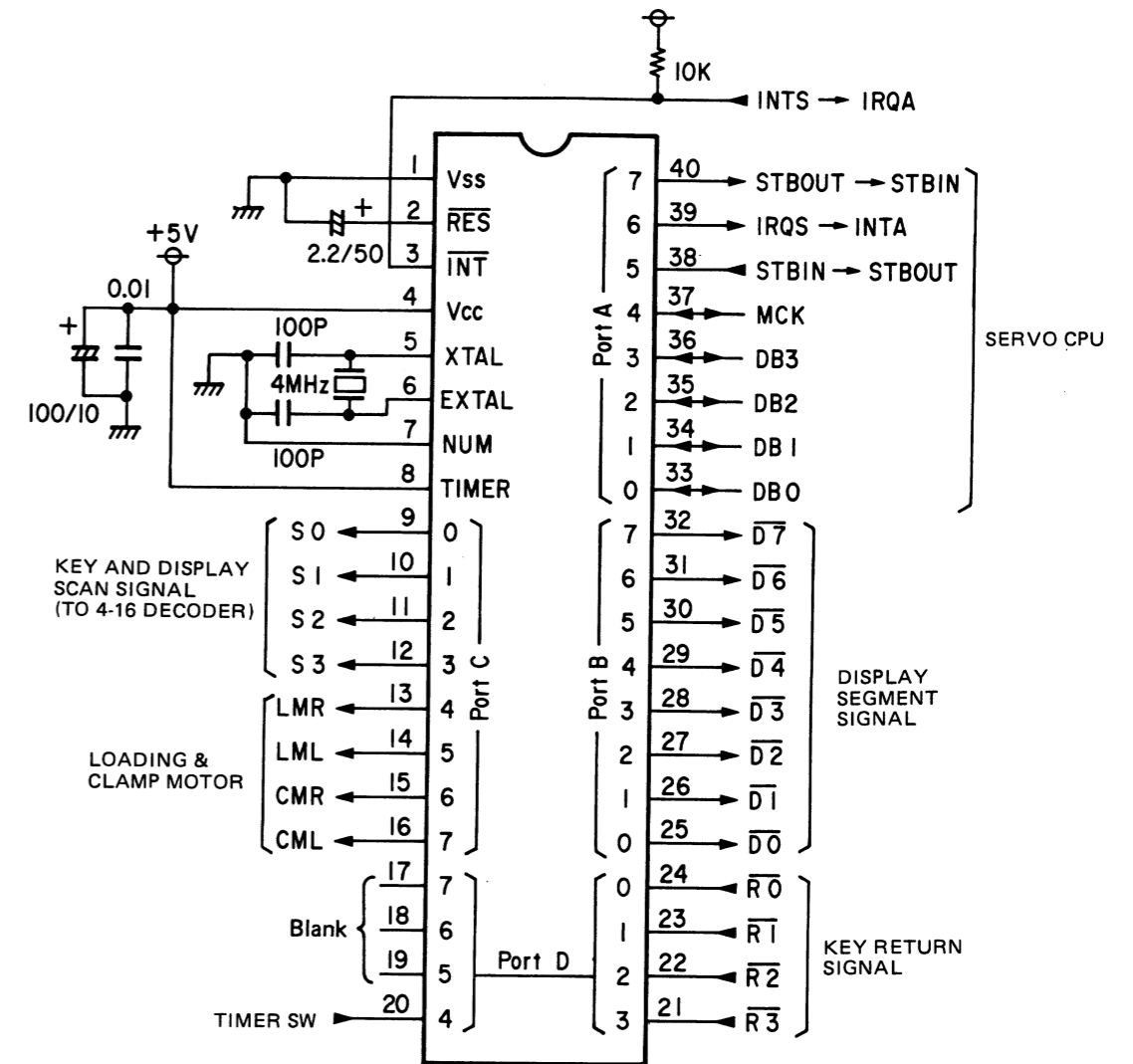

SEMICONDUCTORS

•IC

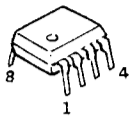

μPC4559-C
TL082-CP
NE5534N
NJM-4560D
HA17903PS
TL081-CP
LF356N

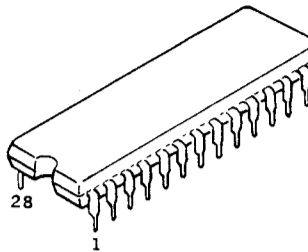
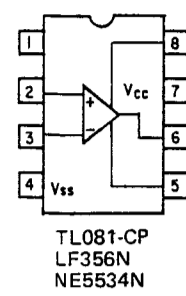
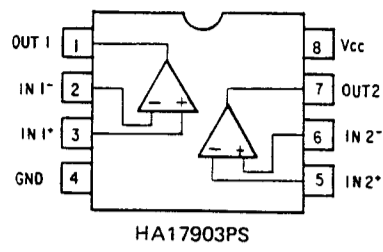
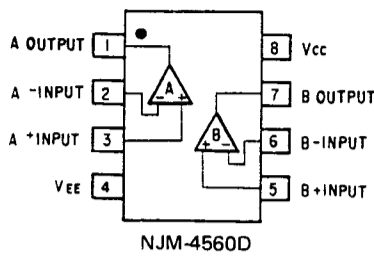
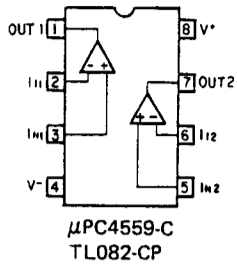

SAA7011 (M4290)

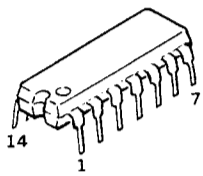

TC4066BP
HD74LS00P
HD74LS122P
HD14023BP
TC40H-004P
HA17901P
M74LS27P
HD74LS04P
HD74LS74AP
HD74LS107AP
HD74LS164P

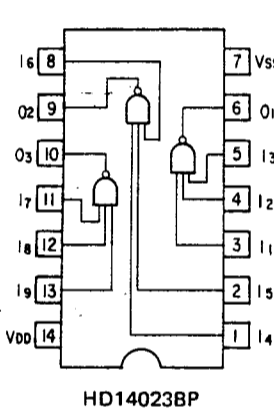
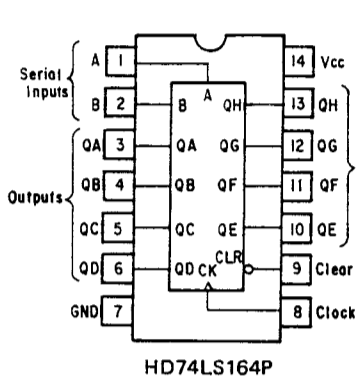
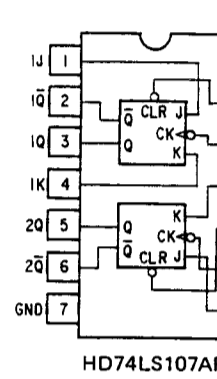
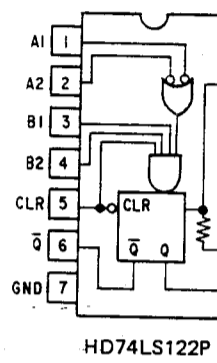
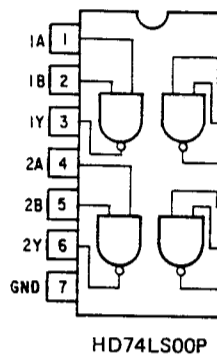
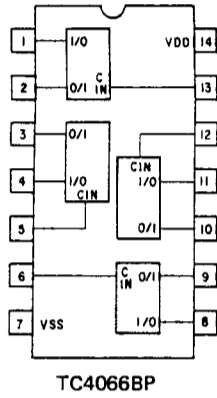

HD14023BP

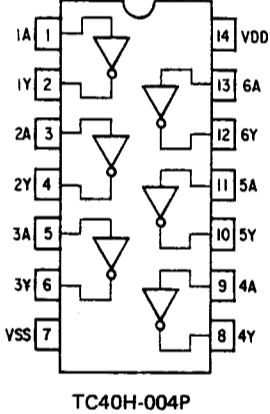

TC40H-004P

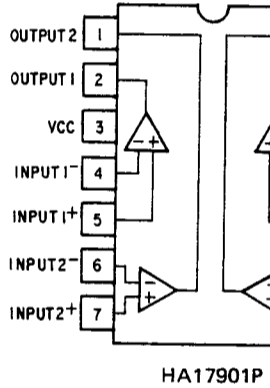

HA17901P

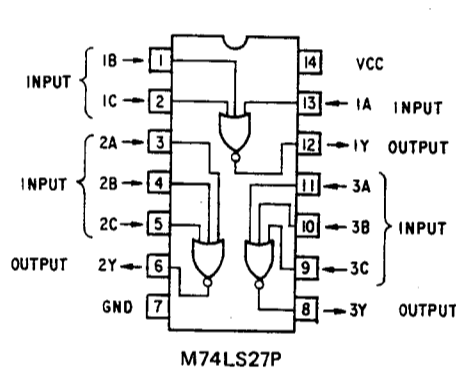

M74LS27P

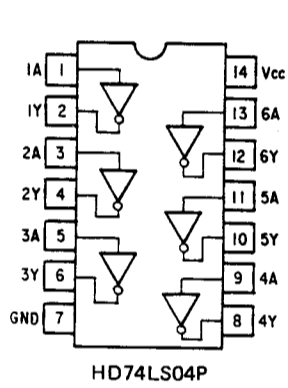

HD74LS04P

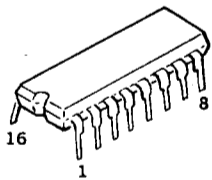

TC4053BP
HD74LS161P
H74LS123P
HD74LS157P
HD74LS161P
HD14053BP

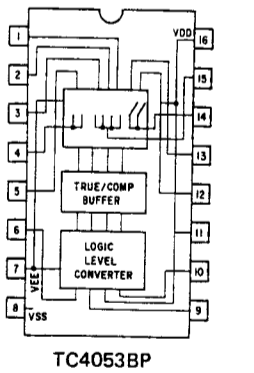

TC4053BP

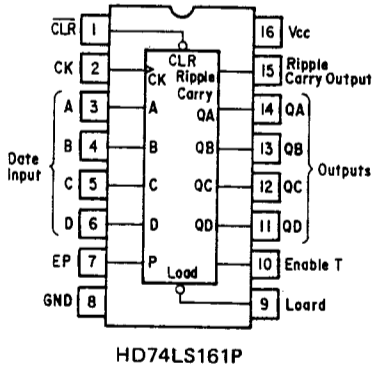

HD74LS161P

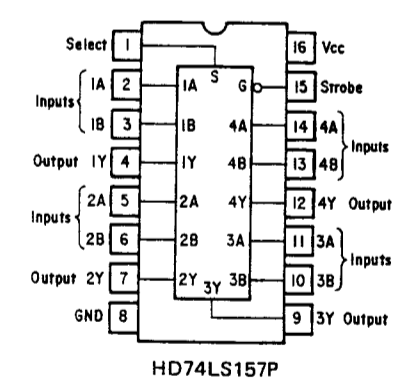

HD74LS157P

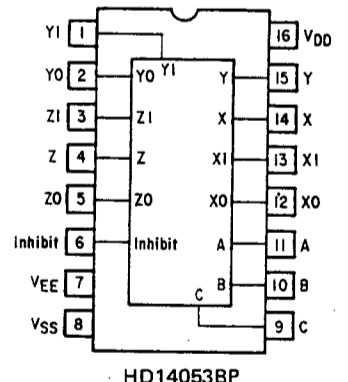

HD14053BP

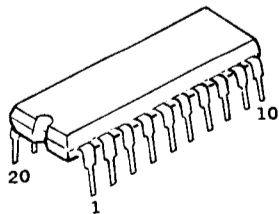

HD74LS273P

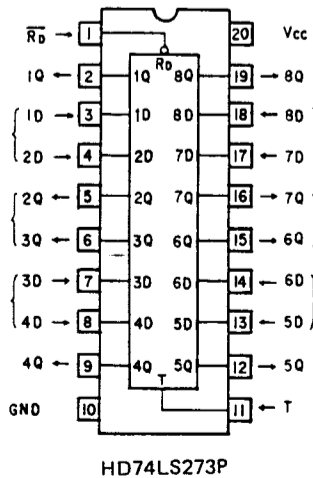

HD74LS273P

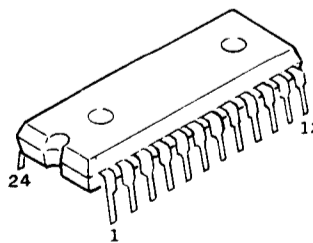

HM6116P-4
PCM53JP-V
HD74LS154P

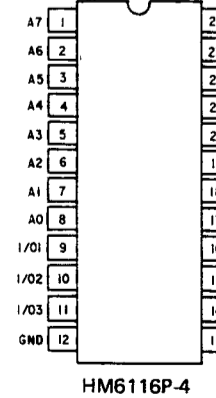

HM6116P-4

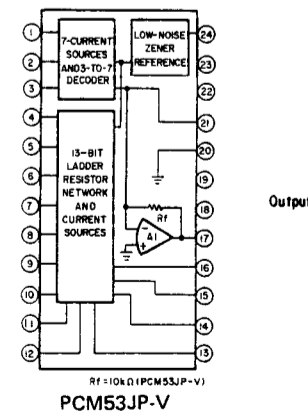

PCM53JP-V

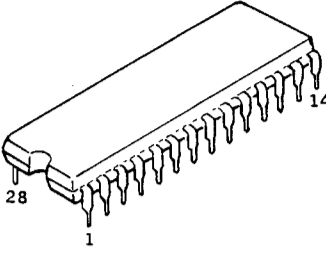

SAA7011 (M4290A)

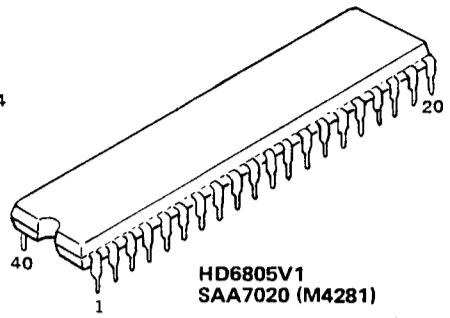

HD6805V1 SAA7020 (M4281)

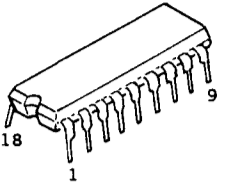

SAA-7000 (M4300)
MSL915RS
MSL917RS
HA12050

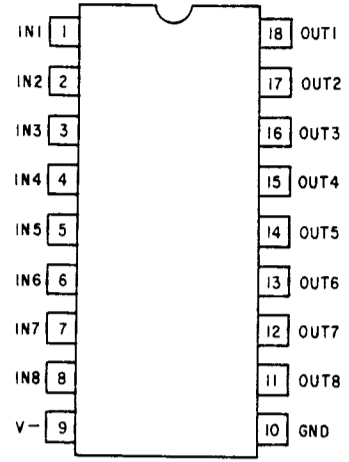

MSL915RS
MSL917RS

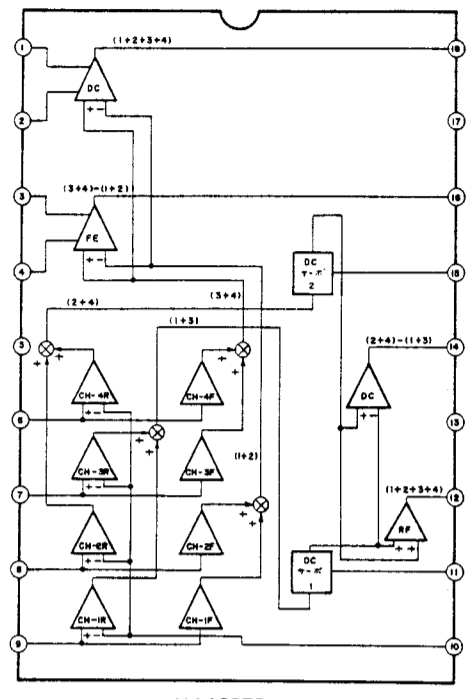

HA12050

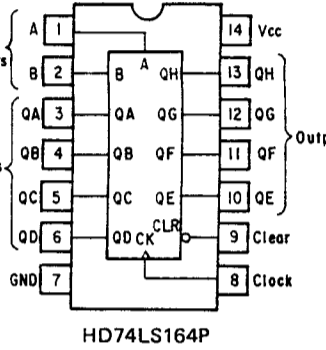

HD74LS164P

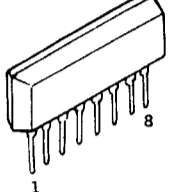

M5218L

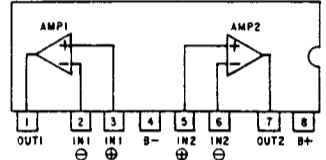

M5218L

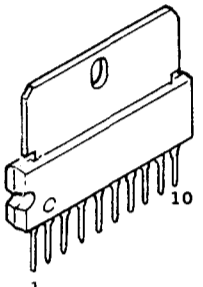

BA6109

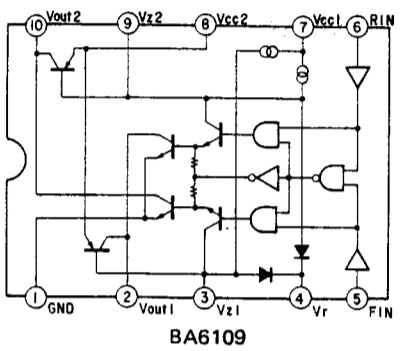

BA6109

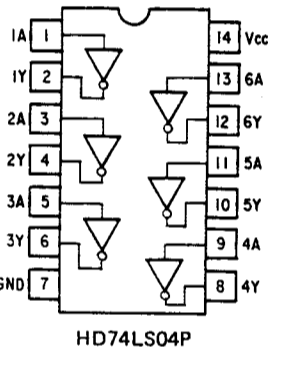

HD74LS04P

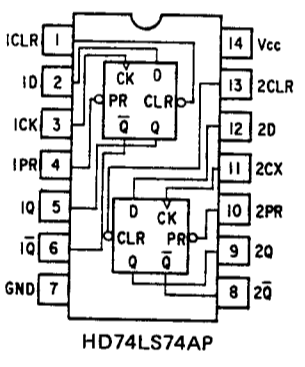

HD74LS74AP

• TRANSISTORS

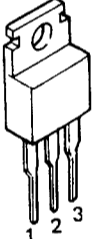

HA178M12P
HA178-05
HA178-15

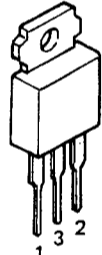

μPC795H
μPC7915H



2SA781K
2SA1015Y
2SC1815Y



2SA966 (Y)
2SB647A
2SC2236 (Y)

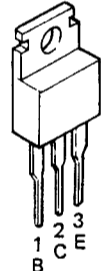

2SA816Y
2SC1626Y

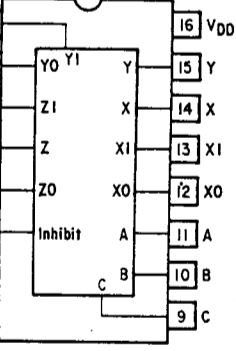

HD14053BP

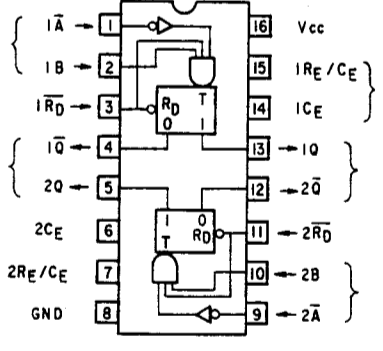

H74LS123P

• DIODES

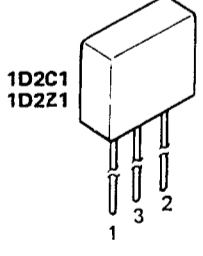

1D2C1
1D2Z1



SVC321SP-D2

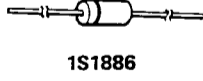

1S1886



HZ5C-1
HZ6C-2
HZ7B
HZ9A-2
HZ12C-2
HZ27-3
1SS106
1S2076

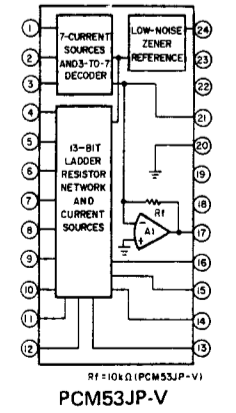

PCM53JP-V

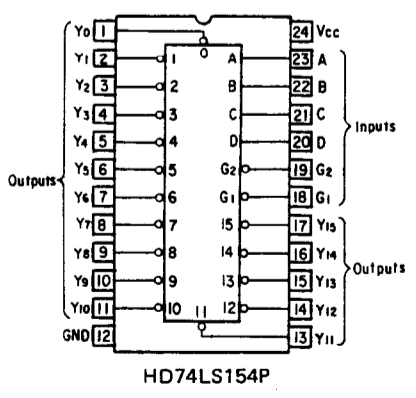

HD74LS154P

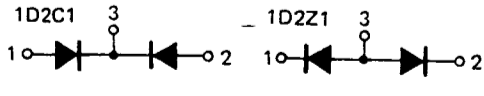

WIRING DIAGRAM

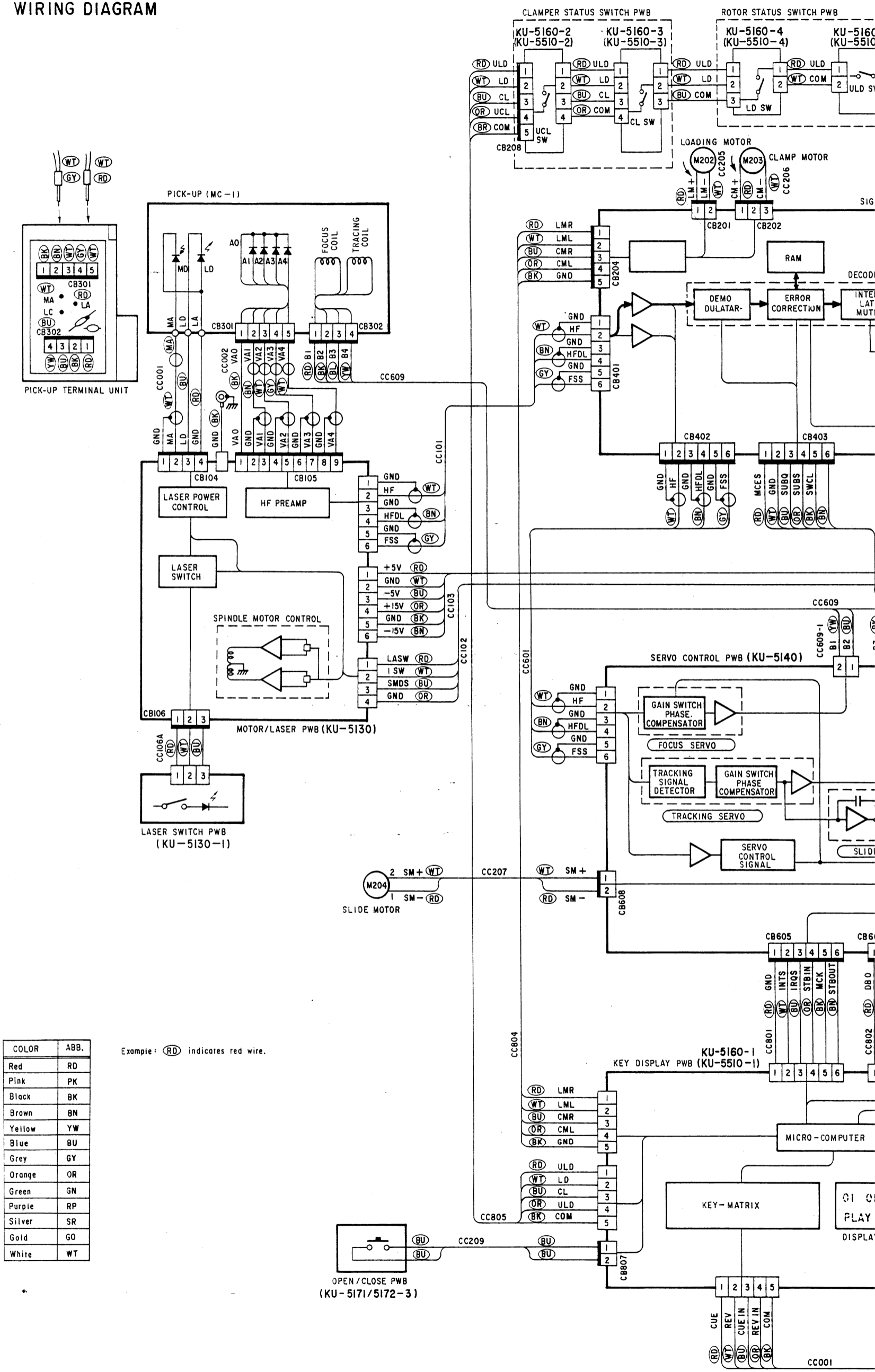

COLOR	ABB.
Red	RD
Pink	PK
Black	BK
Brown	BN
Yellow	YW
Blue	BU
Grey	GY
Orange	OR
Green	GN
Purple	RP
Silver	SR
Gold	GO
White	WT

Example: (RD) indicates red wire.

OPEN / CLOSE PWB (KU-5171/5172-3)

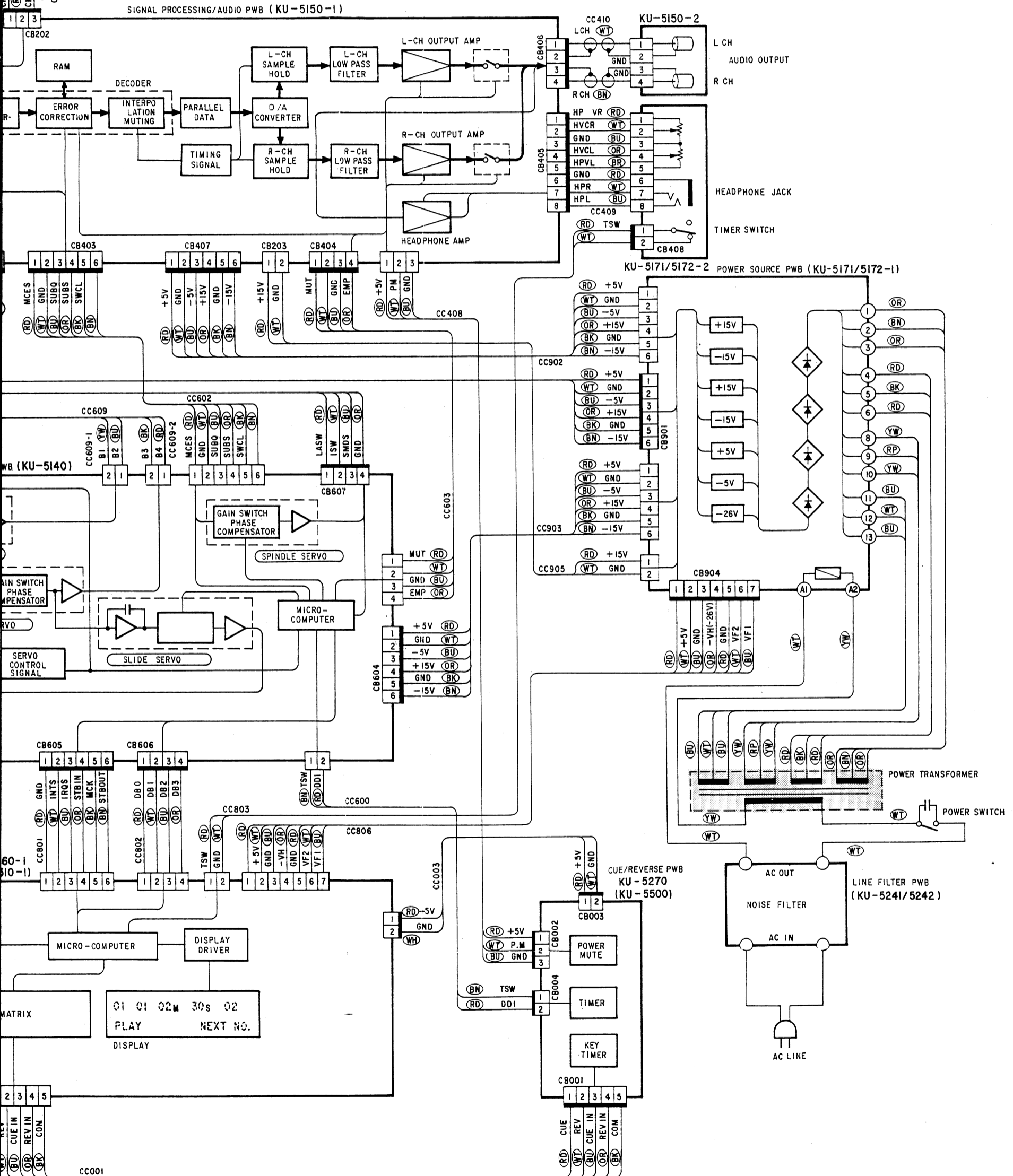
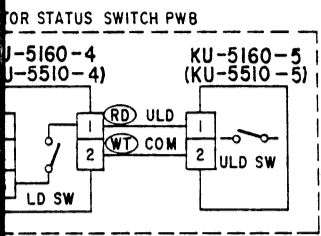

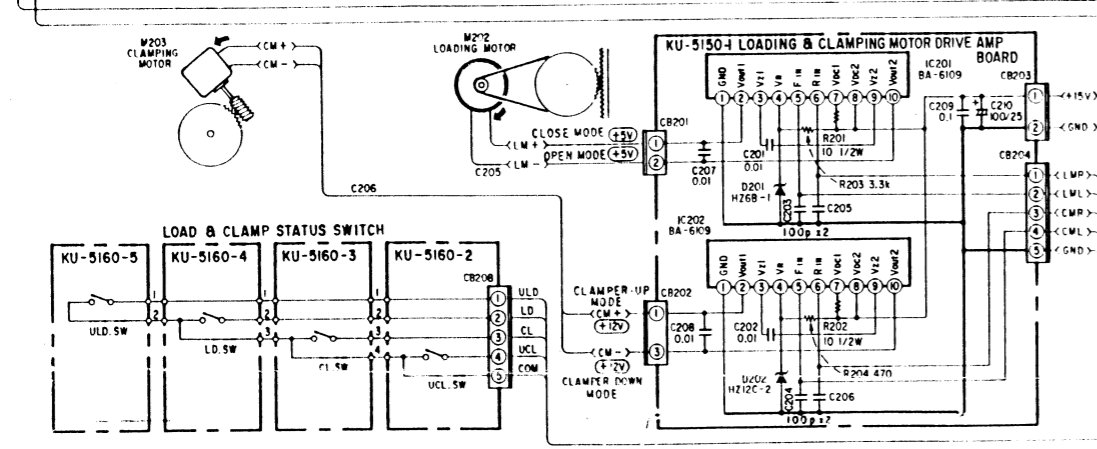
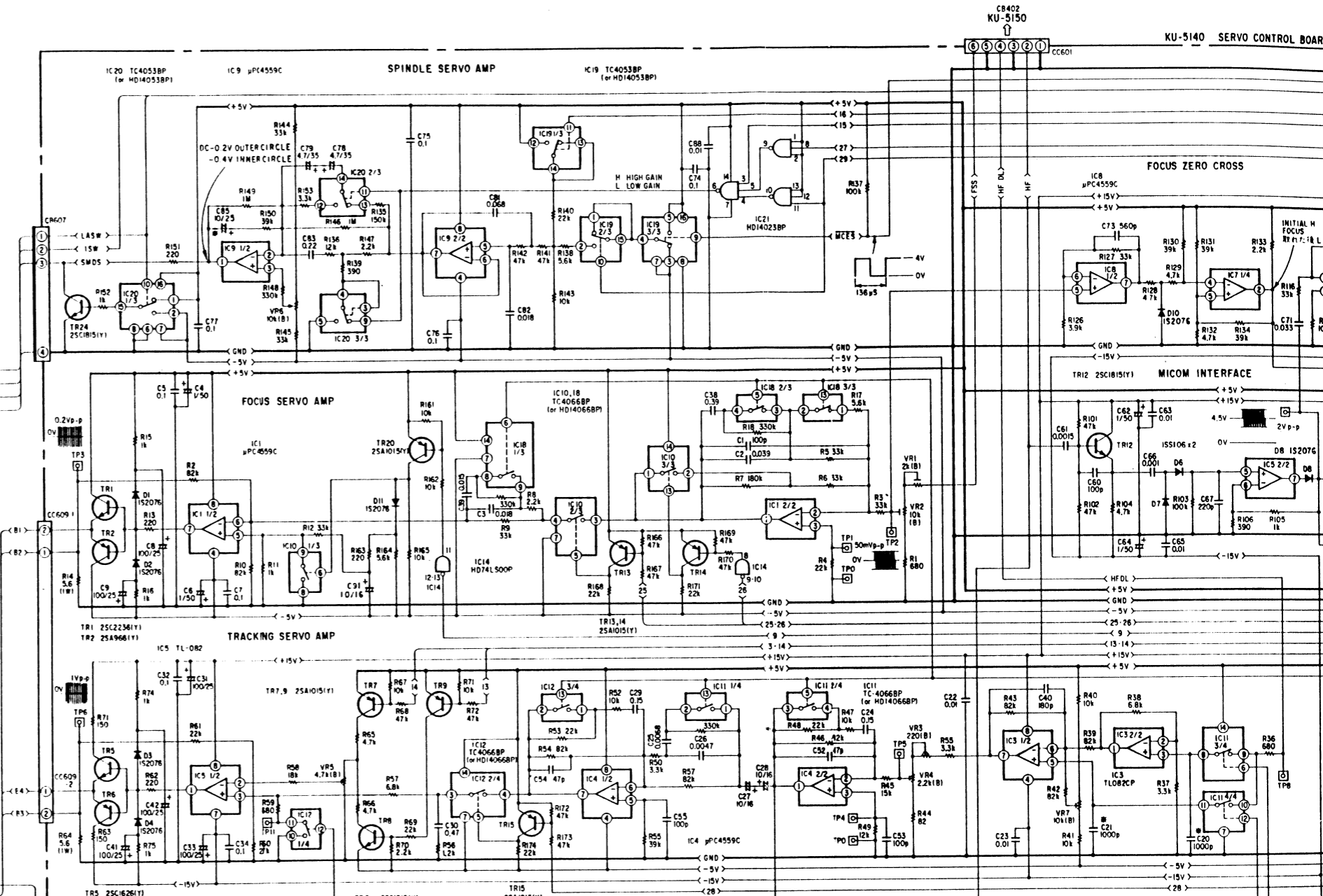
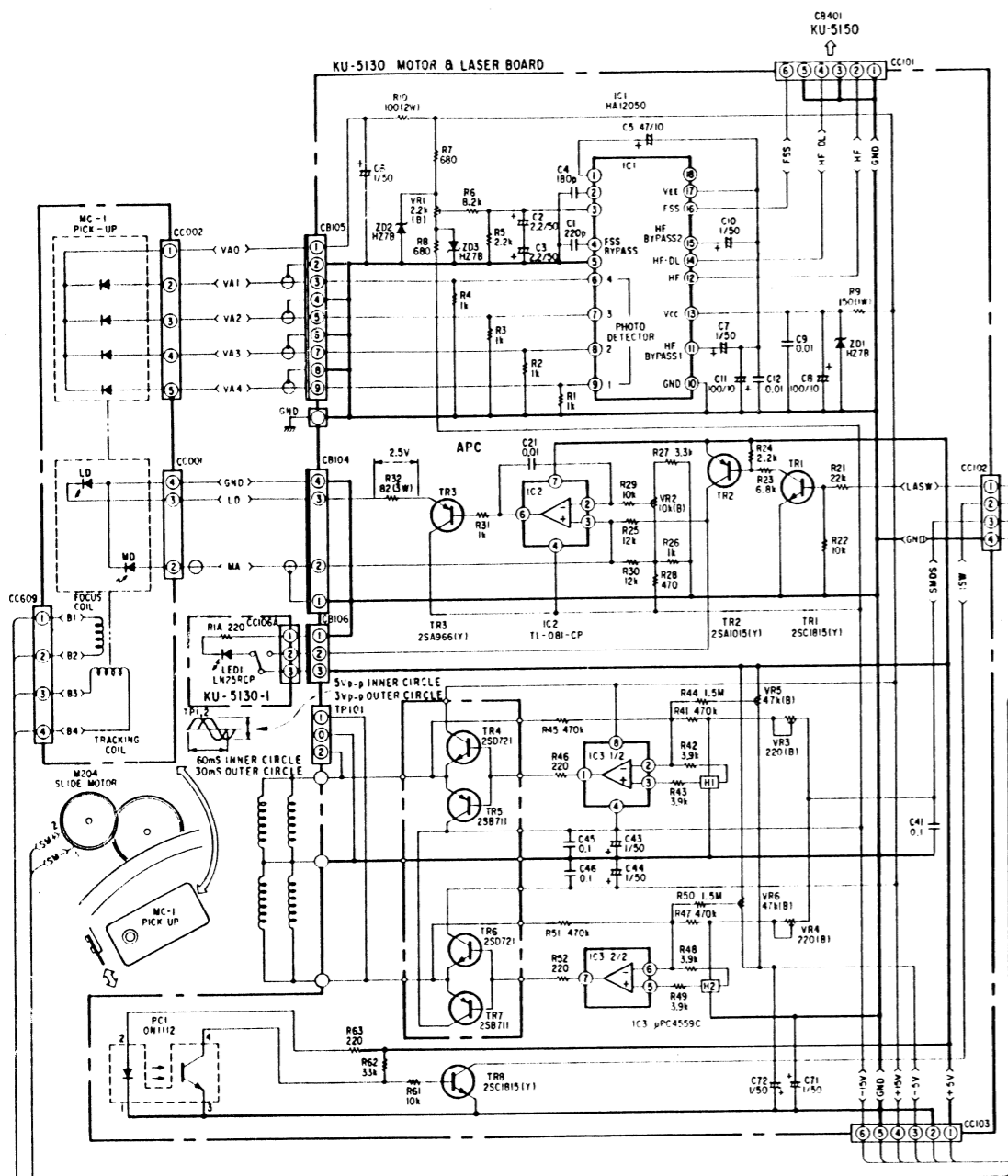

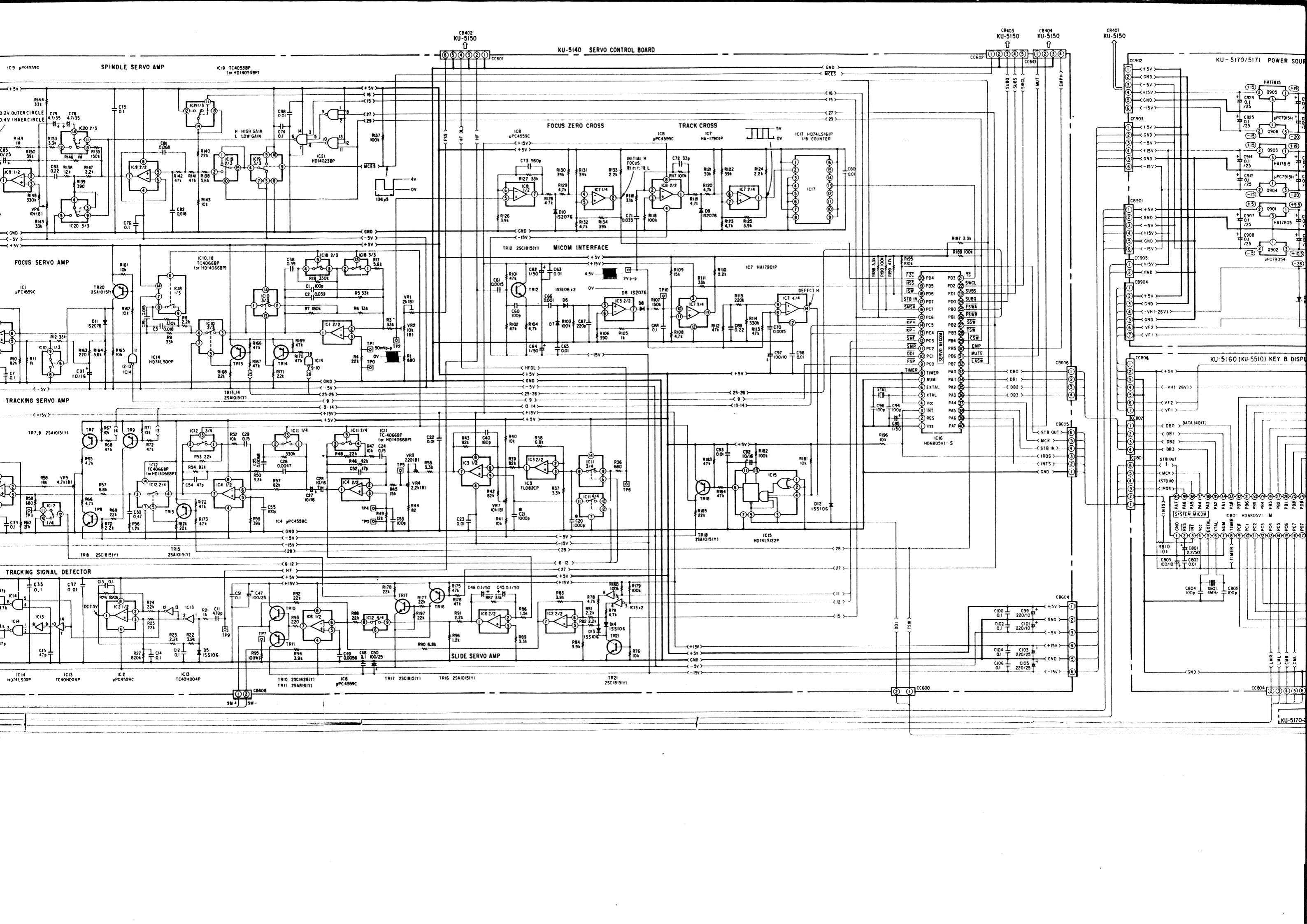

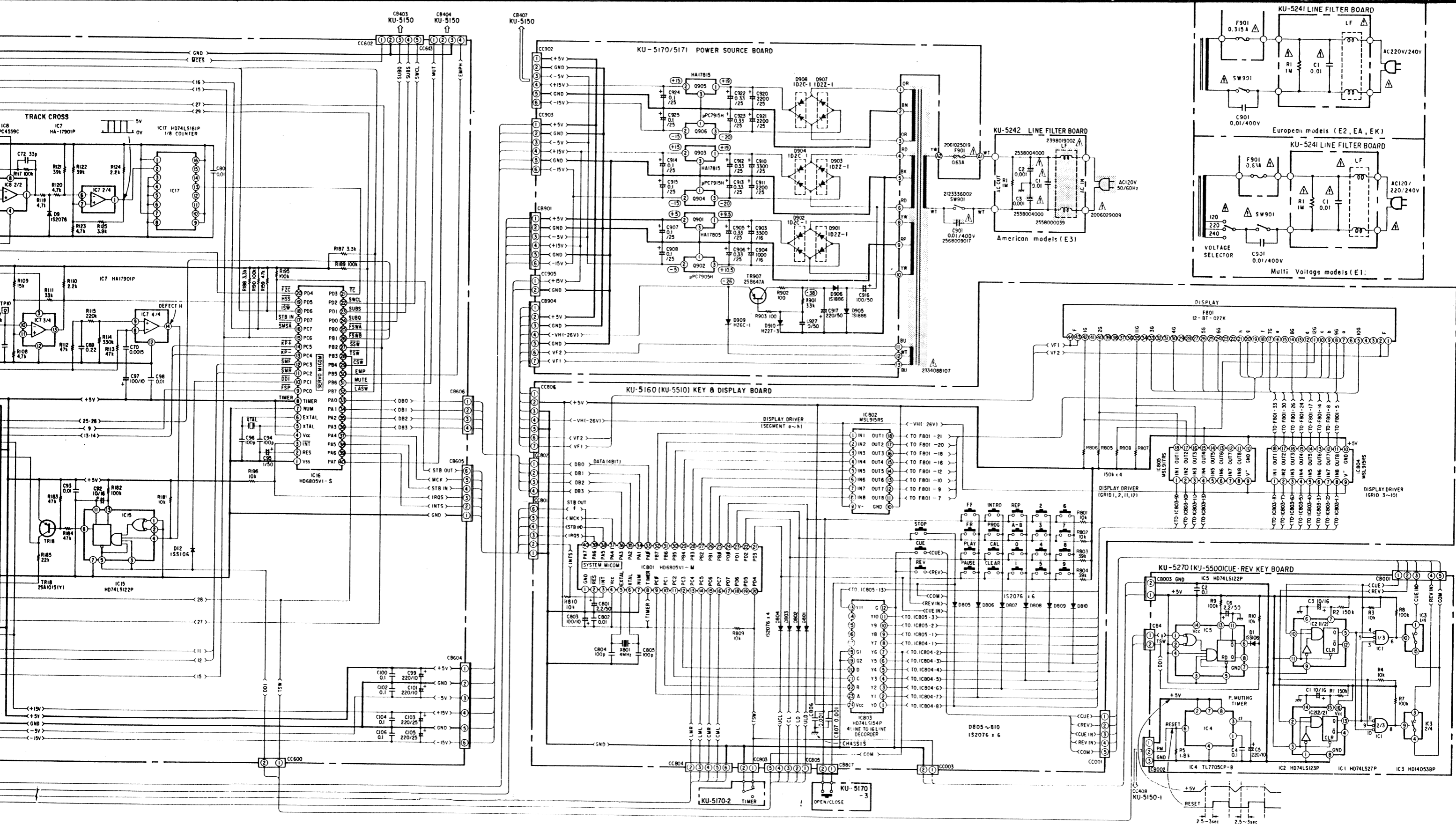

NOTE: 1. UNLESS OTHERWISE SPECIFIED, ALL RESISTOR VALUES ARE IN OHMS, 1/4 WATT.
 2. UNLESS OTHERWISE SPECIFIED, ALL CAPACITANCE VALUES ARE IN μ F, P=PF.
 3. PARTS INDICATED WITH Δ MARKS ARE IMPORTANT DUE TO MAINTAINING SAFETY AND MUST BE REPLACED WITH SPECIFIED ONES.
 4. THIS SCHEMATIC DIAGRAM IS BASIC CIRCUITRY AND SUBJECT TO CHANGE WITHOUT NOTICE FOR FURTHER IMPROVEMENT.

SCHEMATIC DIAGRAM

KU-5150 SIGNAL PROCESSING BOARD

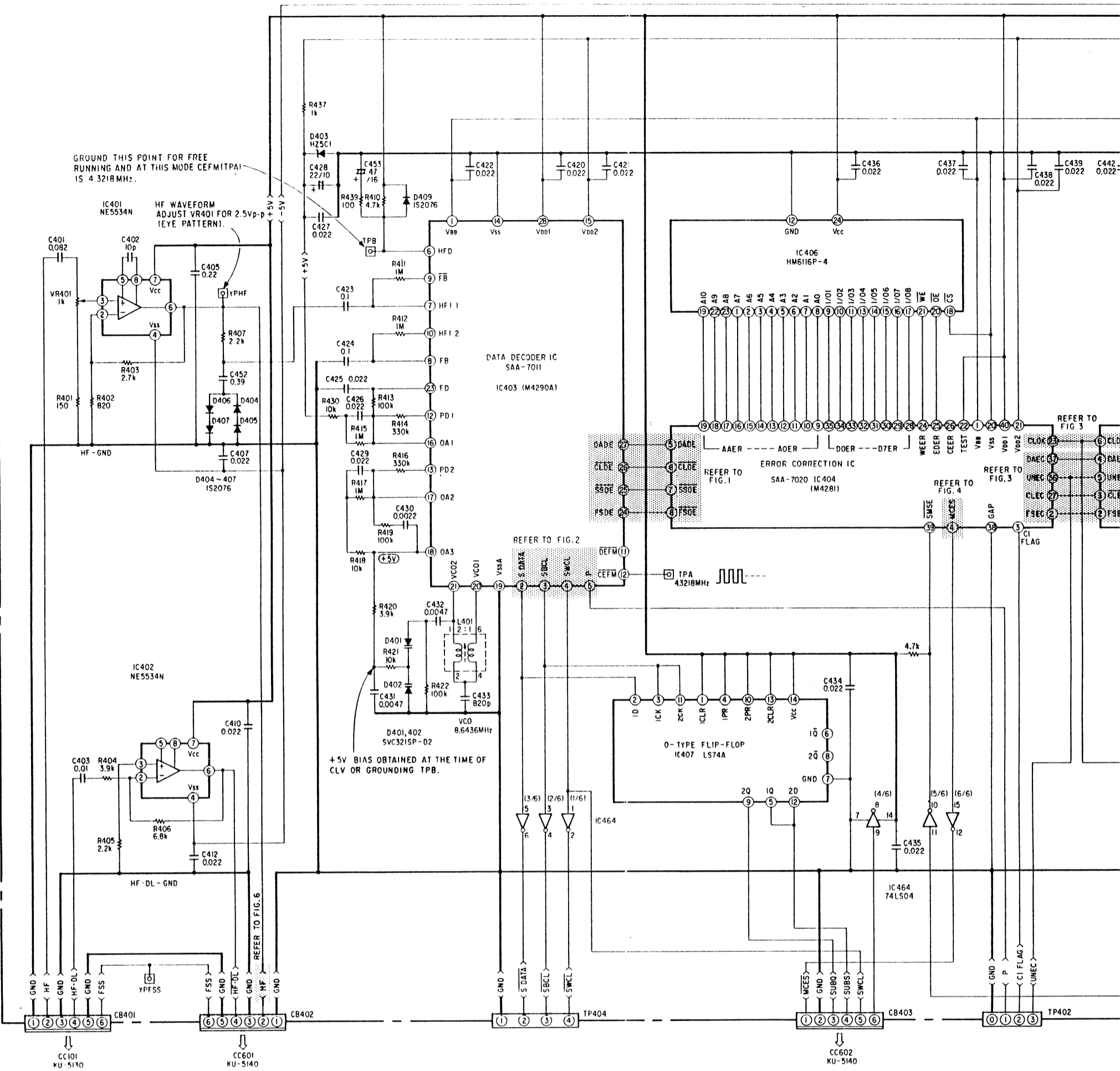

GROUND THIS POINT FOR FREE RUNNING AND AT THIS MODE CEFMTPA IS 4.3218MHZ.

HF WAVEFORM ADJUST VR401 FOR 2.5Vp-p (EYE PATTERN).

DATA DECODER IC SAA-7011 IC403 (M4290A)

ERROR CORRECTION IC SAA-7020 IC404 (M4281)

0-TYPE FLIP-FLOP IC407 LS74A

+5V BIAS OBTAINED AT THE TIME OF CLV OR GROUNDING TPB.

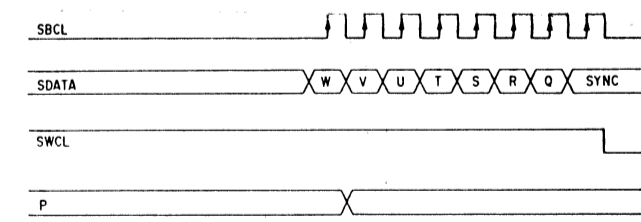
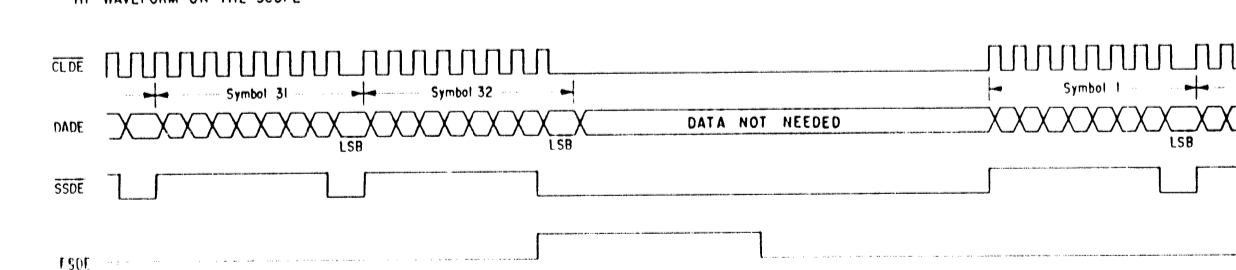
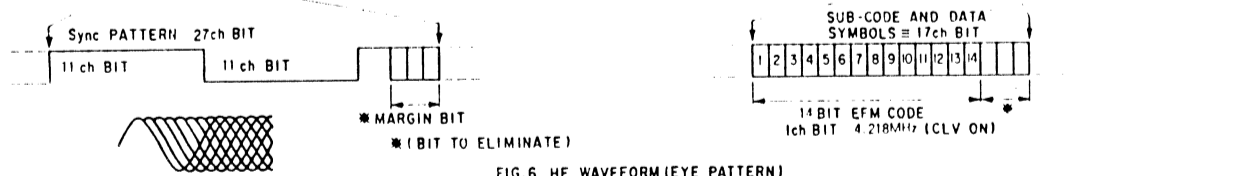
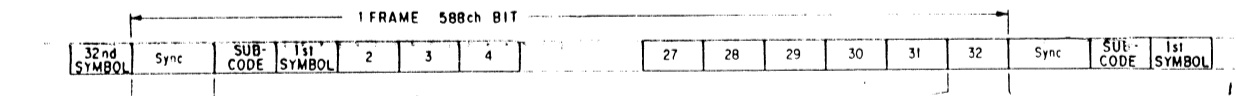

NOTES FOR PINS
 SBCL SUB-CODE BIT CLOCK
 SDATA SUB-CODE DATA
 SWCL SUB-CODE WORD CLOCK
 P SUB-CODE PAUSE BIT

FIG. 2 SAA7011 (IC403) SUB-CODE OUTPUT (SDATA · SBCL · P)

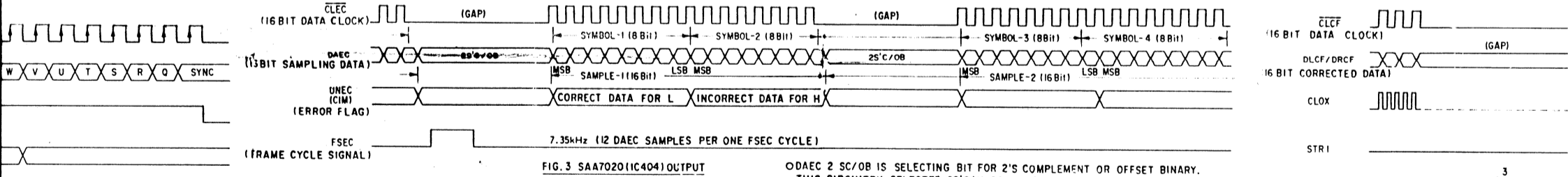
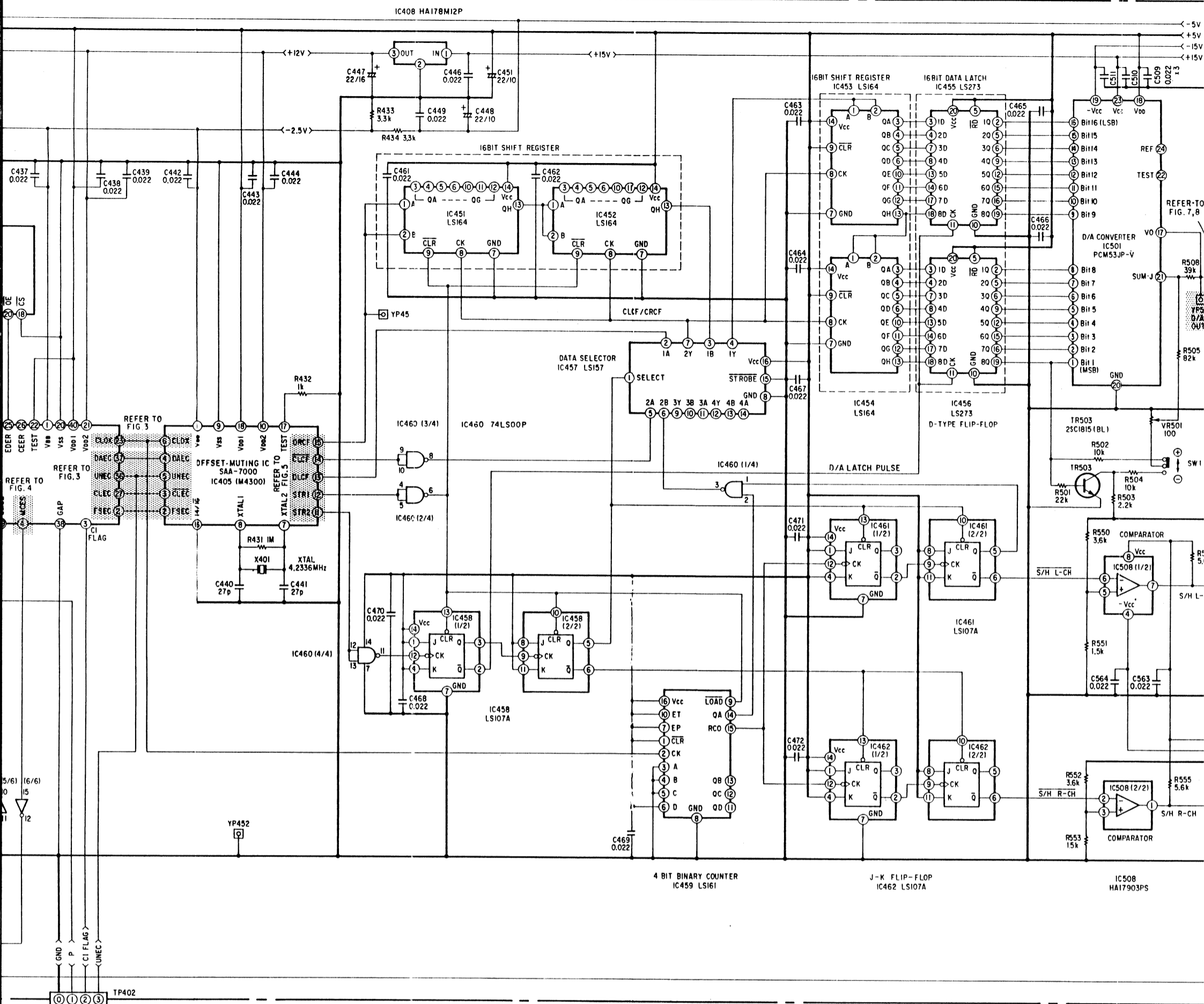

FIG. 3 SAA7020 (IC404) OUTPUT

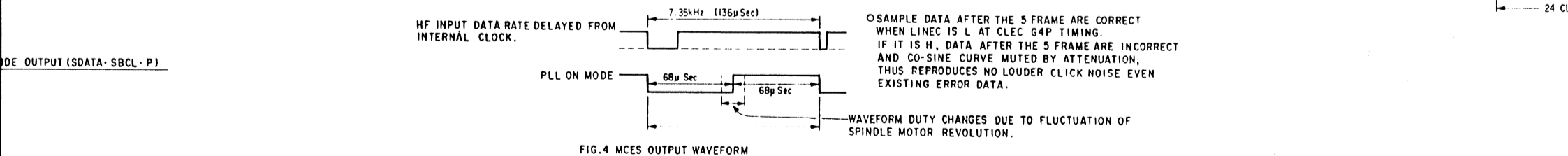

FIG. 4 MCES OUTPUT WAVEFORM

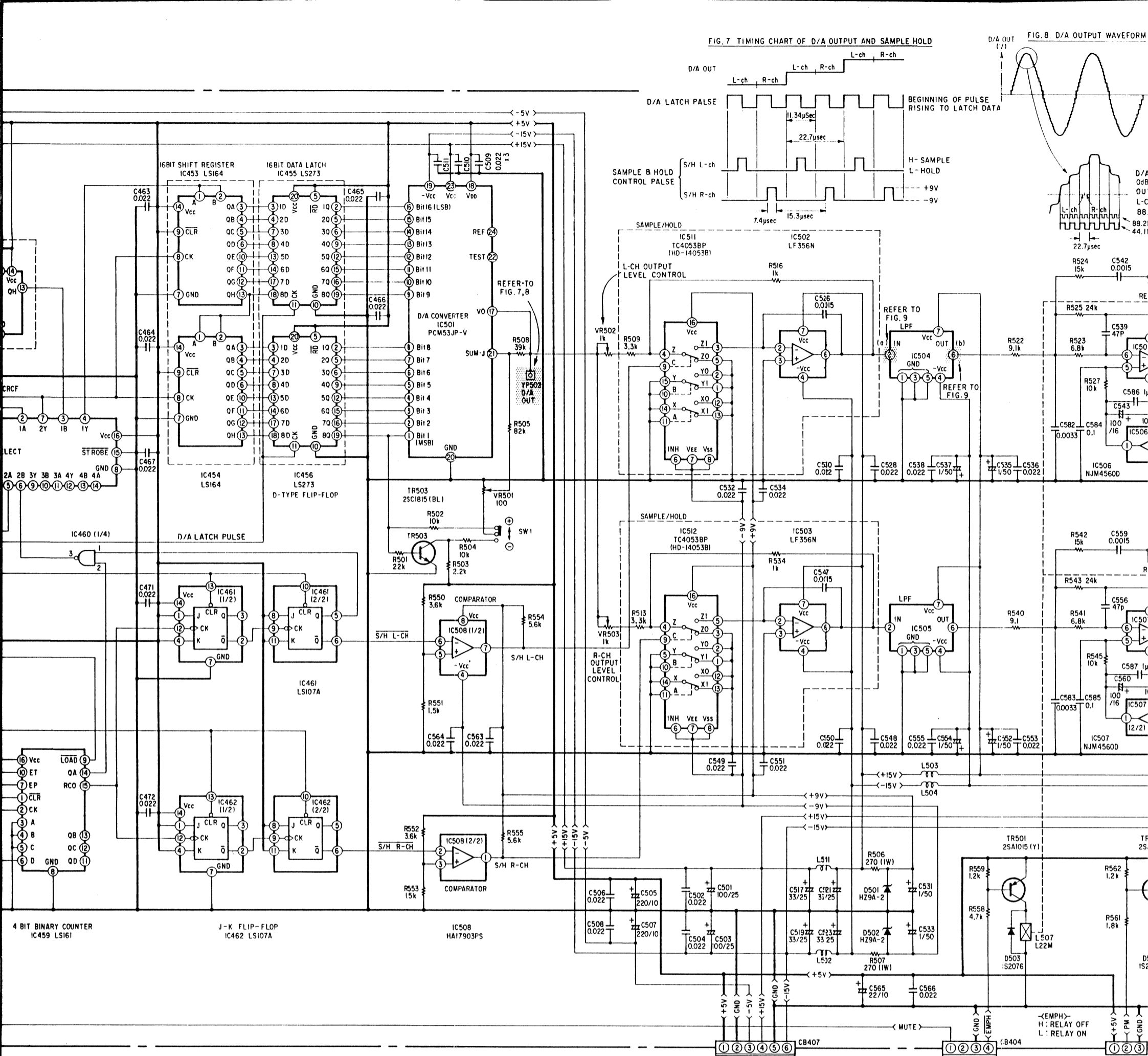

FIG. 7 TIMING CHART OF D/A OUTPUT AND SAMPLE HOLD

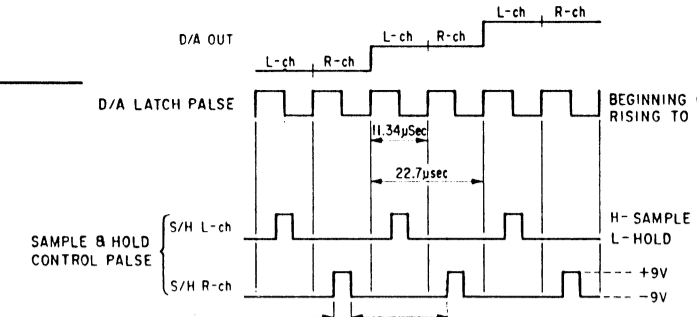

FIG. 8 D/A OUTPUT WAVEFORM

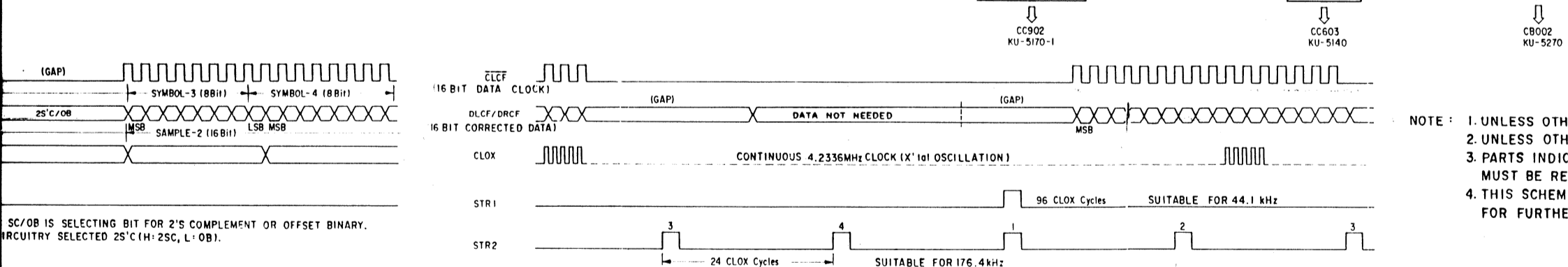
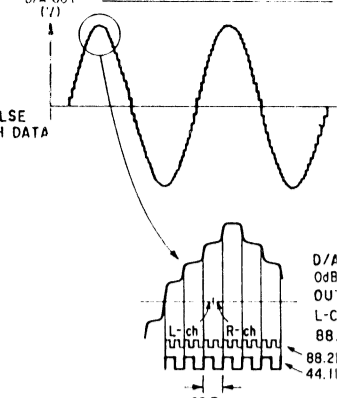

FIG. 5 SAA 7000 (IC405) OUTPUT

NOTE: 1. UNLESS OTHERWISE SPECIFIED, ALL PARTS OTHER THAN IC'S MUST BE RECOMMENDED BY THE MANUFACTURER.
2. THIS SCHEMATIC IS FOR FURTHER INFORMATION ONLY.

SC/OB IS SELECTING BIT FOR 2'S COMPLEMENT OR OFFSET BINARY. CIRCUITRY SELECTED 25'C (H=25C, L=0B).
O SAMPLE DATA AFTER THE 5 FRAME ARE CORRECT WHEN LINE IS L AT CLEC GAP TIMING. IF IT IS H, DATA AFTER THE 5 FRAME ARE INCORRECT AND CO-SINE CURVE MUTED BY ATTENUATION, THUS REPRODUCES NO LOUDER CLICK NOISE EVEN EXISTING ERROR DATA.
WAVEFORM DUTY CHANGES DUE TO FLUCTUATION OF SPINDLE REVOLUTION.

FIG. 7 TIMING CHART OF D/A OUTPUT AND SAMPLE HOLD

FIG. 8 D/A OUTPUT WAVEFORM

FIG. 9 S/H, LPF OUTPUT WAVEFORM

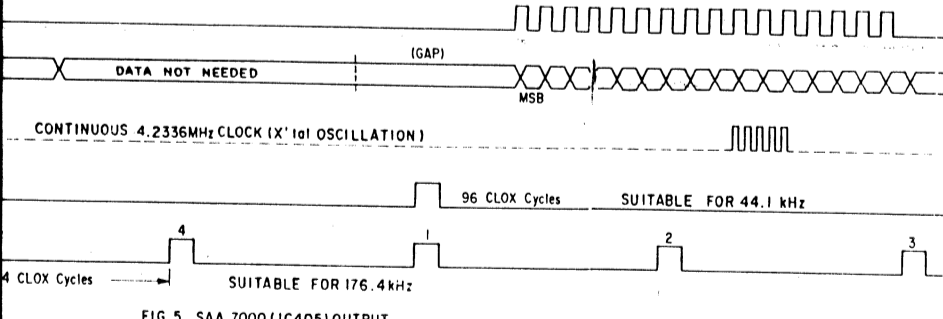
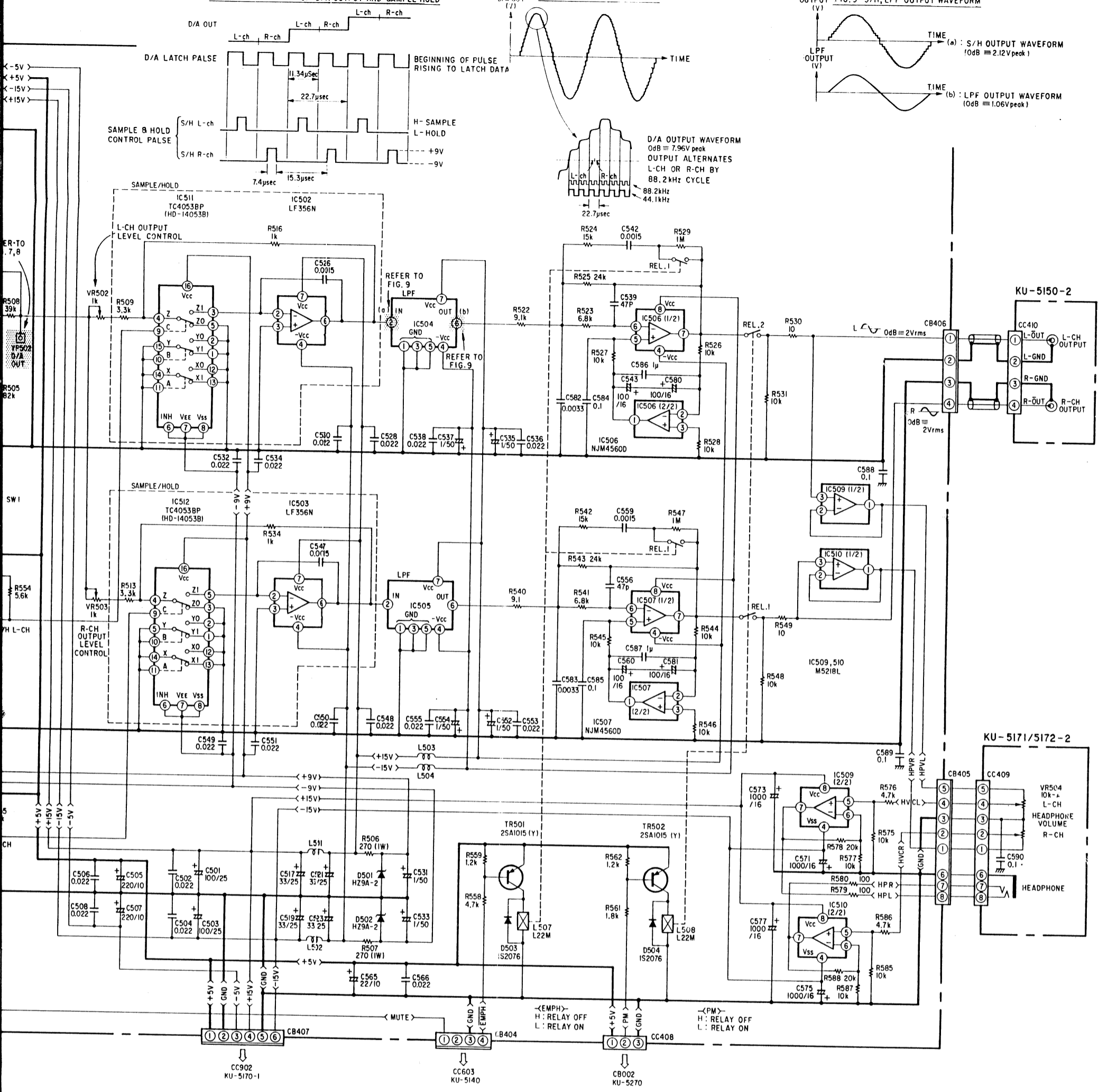

- NOTE:
1. UNLESS OTHERWISE SPECIFIED, ALL RESISTOR VALUES ARE IN OHMS; 1/4 WATT.
 2. UNLESS OTHERWISE SPECIFIED, ALL CAPACITANCE VALUES ARE IN μ F, P=PF.
 3. PARTS INDICATED WITH Δ MARKS ARE IMPORTANT DUE TO MAINTAINING SAFETY AND MUST BE REPLACED WITH SPECIFIED ONES.
 4. THIS SCHEMATIC DIAGRAM IS BASIC CIRCUITRY AND SUBJECT TO CHANGE WITHOUT NOTICE FOR FURTHER IMPROVEMENT.

FIG. 5 SAA 7000 (IC405) OUTPUT