

CD AUTO CHANGER

# KDC-C517FM KDC-C717/Y

# KENWOOD

## SERVICE MANUAL

© 2001-1 PRINTED IN JAPAN  
B51-7731-00 (N) 3394

The MECHANISM OPERATION is the same as model KDC-C710.  
Please refer to the service manual of model KDC-C710 (B51-7104-00).

Service jig	Parts No.
For initial position setting	W05-0635-00

When transporting these models, always attach CAUTION CARD and STEPPED SCREW (for transportation)

Illustration is  
KDC-C517FM.

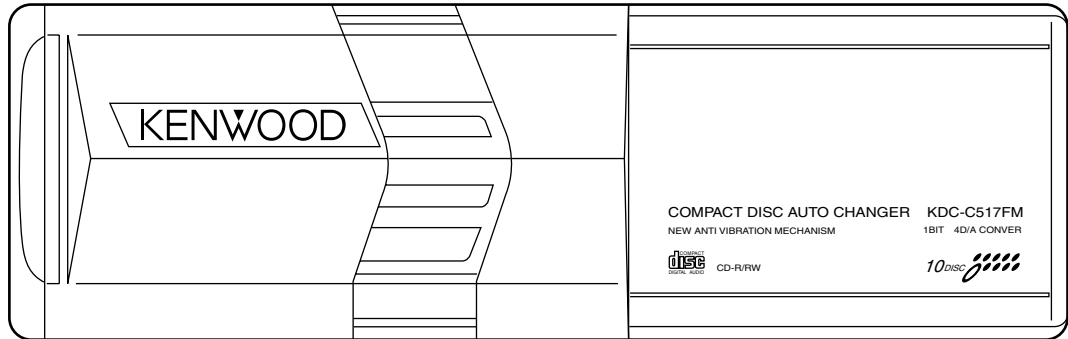
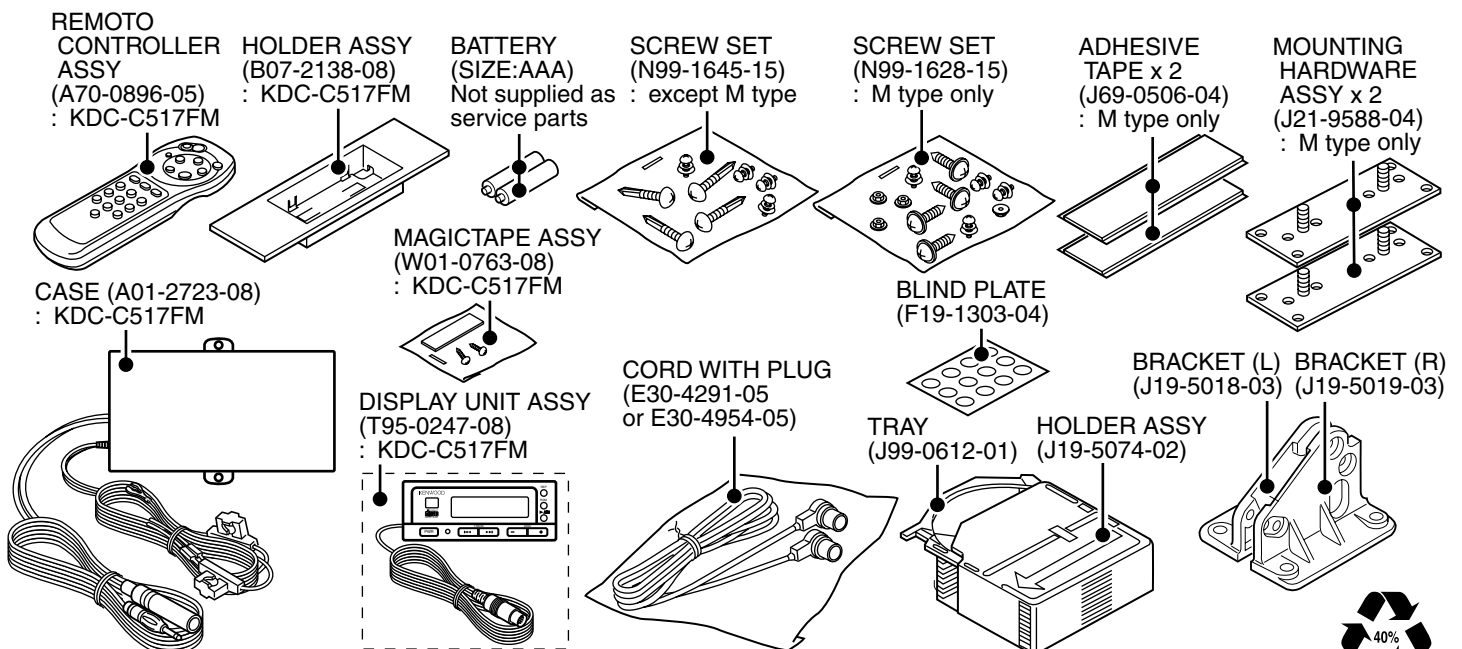
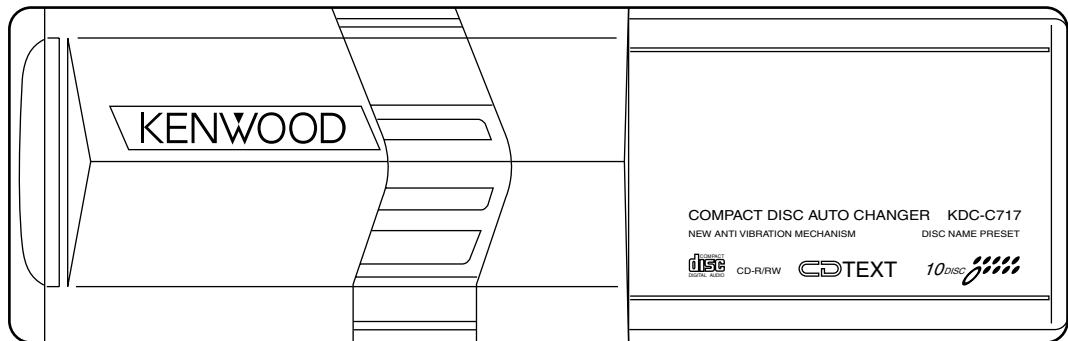
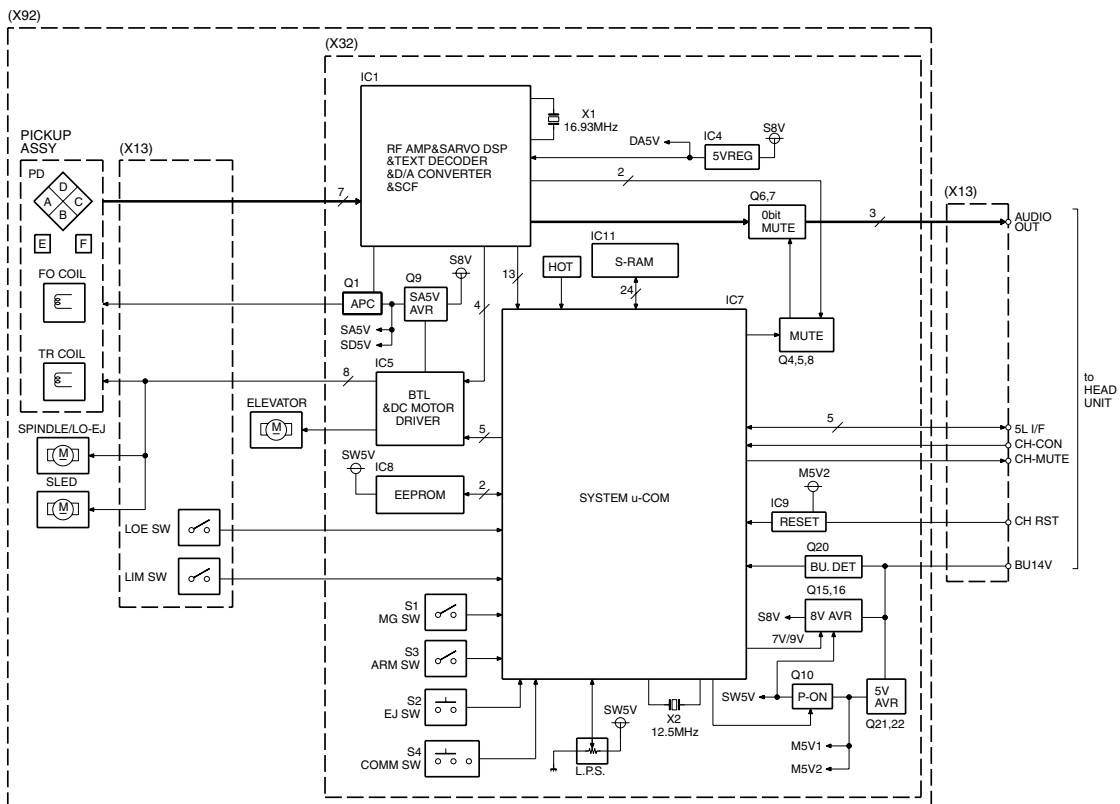
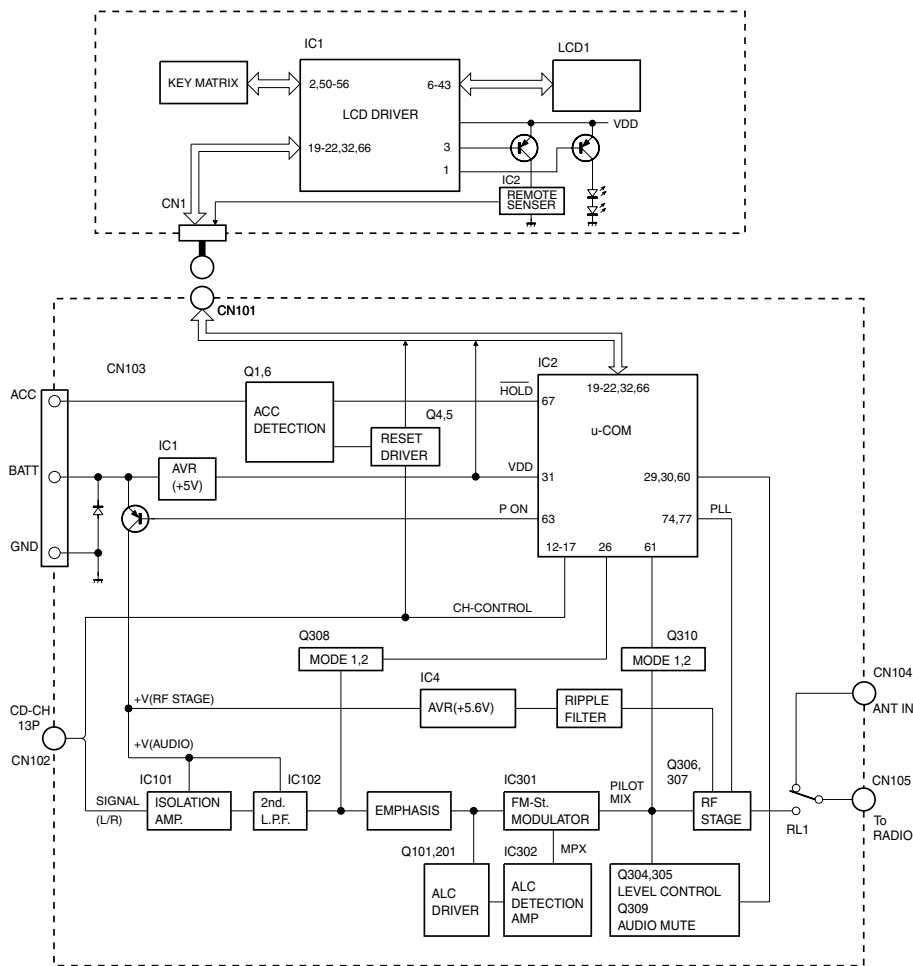

Illustration is  
KDC-C717/Y.



# KDC-C517FM, C717/Y

## BLOCK DIAGRAM



# KDC-C517FM, C717/Y

## COMPONENT DESCRIPTION

### ●CD PLAYER UNIT (X32-5090-0X)

Ref.No.	Component Name	Application/Function	Operation/Condition/Compatibility
IC1	UPD63711AGC	Servo IC	RF amplifier built in digital servo and data processor IC. Focusing, tracking, sled and spindle servo processing. Detection of dropout, anti-shock, track crossing and off-track conditions. Automatic adjustment (focusing, tracking, gain, offset and balance) operations. Digital signal processing (DSP, PLL, sub-codes, CD-TEXT decode, CIRC error correction, audio data interpolaration)operations.
IC4	KIA78L05F	+5V AVR	Analogue output circuit power supply for D/A converter
IC5	LA6576	Motor driver	Focusing coil, tracking coil, spindle motor and sled motor driver. VO1-VO4 and VOL outputs ON/OFF function. While MUTE1 goes "Hi", VO1 outputs are turned on. While MUTE2 goes "Hi", VO2-VO4 and VOL outputs are turned on. VIN1 amplifier function(input selection and VREF selection) 1. Input selection. While VIN SW terminal goes "Lo", IC pin 15, 16 and 17 inputs are selected. While VIN SW terminal goes "Hi", IC pin 15, 18 and 19 inputs are selected. 2. VREF selection. While VIN SW terminal goes "Lo", internal VREF(2.5V typical) is selected. While VIN SW terminal goes "Hi", external VREF(IC pin 30 input) is selected.
IC7	UPD784214GC091	Mechanism MI-COM.	Mechanism and servo control
IC8	BR24C02F-W or CAT24WC02JI or M24C02WMN6T or S-24C02BFJA or 24LC02BT-ISN	EEPROM	LPS data back-up memory
IC9	S-80830ANNP	Reset IC	When BU 5V voltage is less than 3.0V, IC outputs "Lo".
IC11	LC3564BT-70	S RAM	CD-TEXT data memory
Q1	MCH6101	APC	Laser diode auto power control
Q4	DTA124EK	0 bit mute (L CH.)	When 0 bit mute is activated, an emitter goes "Hi", and Q4 outputs "Hi".
Q5	DTA124EUA	0 bit mute (R CH.)	When 0 bit mute is activated, an emitter goes "Hi", and Q5 outputs "Hi".
Q6	DTC343TK	Mute SW (L CH.)	When 0 bit mute or A mute drive is activated, a base goes "Hi", and L channel audio signal is muted.
Q7	DTC343TK	Mute SW (R CH.)	When 0 bit mute or A mute drive is activated, a base goes "Hi", and R channel audio signal is muted.
Q8	DTA124EK	A mute drive	When audio mute of IC7 is activated, a base goes "Lo", and audio mute drive signal is outputted.
Q9	2SB1202	Servo 5V AVR	Q9 is combined with IC5's pin 26 and 27 , and works as a driver of AVR.
Q10	2SB1295	P-ON 5V SW	While base goes "Lo", P-ON 5V is supplied to the microprocessor peripheral circuits.
Q11	DTC124EK	Reset SW	When System Reset has activated, a base goes "Hi", and Q11 is turned on.
Q13	DTC124EUA	CH CON SW	While CH CON or CH-CON2 mode is selected, a base goes "Hi", and Q13 is turned on.
Q14	DTA143EUA	CH MUTE SW	When MUTE REQUEST to H/U is outputted, a base goes "Lo", and Q14 is turned on.
Q16	2SC4081	SRV 8V AVR	Q16 is combined with Q15(X92-), and works as a pre-driver of AVR.
Q17	DTA143EK	SRV 8V AVR SW	When Q18's base goes "Hi", Q17 is turned on, and SVR 8V AVR is working.
Q18	DTC124EUA		
Q19	DTC124EUA	7/9V SW	When a base goes "Hi", Q19 is turned on, and SVR 8V AVR is outputting +7V. When a base goes "Lo", Q19 is turned off, and SVR 8V AVR is outputting +8.5V.
Q20	DTC124EK	BU DETECTION SW	While BACKUP is applied, a base goes "Hi", and Q20 is turned on. When momentary power down has detected, a base goes "Lo", and Q20 is turned off.
Q21	2SB1202	BU 5V AVR	While BACKUP is applied, AVR outputs +5V. Q21 and Q22 are inverted Darlington connection.
Q22	2SC4081		
Q30	DTC114YUA	Eccentric disc SW	When an eccentric disc is detected, Q30 is turned on, and a preceding beam is made to be delayed.
Q31	DTC124EUA	VIN SW	While spindle servo or disc loading/eject mode is selected, a base goes "Hi", and Q31 is turned on.

# KDC-C517FM, C717/Y

## COMPONENT DESCRIPTION

### ●RF MODULATOR UNIT

Ref.No.	Component Name	Application/Function	Operation/Condition/Compatibility
IC1	UPC7805AHF	BU 5V AVR	While BACKUP is applied, AVR outputs +5V.
IC2	LC72329-9274	System MI-COM.	System control
IC4	NJM78L05UA	5V AVR	Power supply for FM modulator and RF amplifier
IC101	NJM2060M	Isolation amp.	
IC102	NJM4565MD	Low pass filter	
IC301	BA1405F	FM ST modulator	
IC302	NJM4565MD	1/2 VCC driver, ALC detection amp.	
Q1	DTC124EK	ACC detection	When Q4 is turned on , Q1 is turned on during ACC applied.
Q2	2SA1782(T,U)	POWER SW	When Q3's base goes "Hi", Q2 is turned on, and RF modulator circuit is working.
Q3	DTC124EK		
Q4	DTC143TK	Reset SW	When RESET SW on display unit is pressed, Q4,Q1 and Q6 are turned off, and IC2 is holding.
Q5	DTC143TK	CH RESET SW	When RESET SW on display unit is pressed, Q5 is turned off, and SYSTEM RESET signal is outputted to CD changer.
Q6	DTA124EK	Hold detection SW	When RESET SW on display unit is pressed or ACC is OFF, Q6 is turned off, and IC2 is holding.
Q8	DTC143TK	Relay driver	FM modulator output / Vehicles antenna input switching. When a base goes "Hi", FM modulator output is selected.
Q9	2SC4640(T,U)	Ripple filter	Power supply for RF amplifier
Q101	2SK2158	ALC control SW	
Q201	2SK2158		
Q303	2SA1162(GR)	Pilot mix amp.	
Q304	2SK2158	Level control SW	Level1/2 : OFF, Level3/4 : ON
Q305	2SK2158	Level control SW	Level2/4 : OFF, Level1/3 : ON
Q306	2SK508L	RF oscillator buffer	
Q307	2SC2714(Y)	RF amp.	
Q308	2SK2158	Mode(1/2) SW	Mode1 : ON, Mode2 : OFF
Q309	2SK2158	Audio mute	POWER ON mode : OFF, POWER OFFmode : ON
Q310	2SK2158	Mode(1/2) SW	Mode1 : OFF, Mode2 : ON

### ●DISPLAY UNIT

Ref.No.	Component Name	Application/Function	Operation/Condition/Compatibility
IC1	LC75852W	LCD driver with key-matrix	
IC2	PNA4602M	Remote control light sensor	
Q1	DTC144EK	LED ON/OFF SW	When Q1's base goes "Hi", Q2 is turned on, and LED is turned on.
Q2	DTB123YK		
Q3	DTA144EK	Key-matrix permition SW	Ready on key-matrix
Q4	DTC144EK	IC2 ON/OFF SW	When Q4's base goes "Hi", Q5 is turned on, and 5V is supplied to remote control sensor .
Q5	DTA114EK		

# KDC-C517FM, C717/Y

## MICROCOMPUTER'S TERMINAL DESCRIPTION

●IC7 (CD PLAYER UNIT : X32-5090-0X)

Pin No.	Pin Name	I/O	Description	Processing Operation
1	NOR/RW	O	CD-DA/CD-RW Switching	Not used(N.C.)
2	TSTB	O	CD-TEXT parameter strobe	
3	P-CON	O	P-CON output	Not used(N.C.)
4	FOK	I	Focus OK input	"Hi" : Focus OK
5	XTALEN	O	Servo IC oscillation stop control	"Hi" : Oscillation stop
6	RST	O	Servo IC reset terminal	"Lo" : Reset
7	SAO	O	Servo IC command/parameter setting terminal	"Hi" : Parameter setting, "Lo" : Address register setting
8	SSTB	O	Servo IC command/parameter setting strobe terminal	"Hi"→"Lo" : Serial data latch
9	VDD	-	Positive power supply connection terminal	Connected to D 5V lines.
10	X2	-	Main clock resonator connection terminal 2	
11	X1	I	Main clock resonator connection terminal 1	
12	VSS	-	Ground connection terminal	Connected to GND lines.
13	XT2	-	Sub clock resonator connection terminal 2	Not used(N.C.)
14	XT1	I	Sub clock resonator connection terminal 1	Not used(connected to GND lines.)
15	RESET	I	System reset input	"Lo" : System reset
16	FOGUP	I	Vibration detect input	"Hi" : Vibration detect
17	MGSW	I	Magazine switch input	"Hi" : Magazine in
18	EJSW	I	Eject switch input	"Hi" : Eject switch ON
19	COMMSW	I	5-line communication old/new switch input	"Hi" : New communication, "Lo" : Old communication
20	PACK	I	Text data pack synchronous signal input	"Hi"→"Lo" : The head of the pack data
21	CH-CON	I	Changer control input	"Hi" : Standby mode, "Lo" : Operation mode
22	BUDET	I	Momentary power down detection input	"Hi" : When momentary power down detected or BU OFF "Lo" : BU ON
23	AVDD	-	A/D converter positive power supply connection terminal	Connected to D 5V lines.
24	AVREF0	I	A/D converter reference voltage input	Connected to PON 5V lines.
25	HOT	I	Rise in temperature detection input	
26	LPS	I	LPS Mechanical deck position detection input	
27	LOESW	I	Loading complete switch input	"Lo" : Loading complete
28	LIMSW	I	Limit switch input	"Lo" : Pickup most inner position
29	TOFF	I	Tracking OFF mode terminal	Not used(pull down to GND lines.)
30	ADJSEL	I	Servo automatic adjustment ON/OFF terminal	Not used(pull down to GND lines.)
31	TBANK	I	Tracking gain switching mode terminal	Not used(pull down to GND lines.)
32	SIM2	I	Destination input 2	Not used(pull down to GND lines.)
33	AVSS	-	A/D, D/A converter ground connection terminal	Connected to GND lines.
34	LPSCO	O	LPS A/D converter reference power control output	Not used(N.C.)
35	AMUTE	O	Audio mute output	"Lo" : Audio mute ON
36	AVREF1	I	D/A converter reference voltage input	Connected to D 5V lines.
37	SDI	I	Servo IC communication serial data input	
38	SDO	O	Servo IC communication serial data output	
39	SCK	O	Servo IC communication serial clock output	
40	DATAH	I	Data input from H/U	

# KDC-C517FM, C717/Y

## MICROCOMPUTER'S TERMINAL DESCRIPTION

Pin No.	Pin Name	I/O	Description	Processing Operation
41	DATA C	O	Data output from the changer	
42	HCLK	I/O	Communication clock input/output with H/U	
43	RECQC	O	Communication request to H/U	"Lo" : Communication requested
44	CHMUTE	O	Audio mute request to H/U	"Lo" : Audio mute requested
45	TSI	I	Text data input from servo IC	
46	TSO	O	Text data output to servo IC	
47	T SCK	O	Text data clock to servo IC	
48-55	A0-A7	O	Address setting terminal for S RAM	
56-63	D0-D7	I/O	Data input/output terminal with S RAM	
64-68	A8-A12	O	Address setting terminal for S RAM	
69-71	A13-A15	O	Chip enable setting terminal for S RAM	Not used(pull down to GND lines.)
72	VSS	-	Ground connection terminal	Connected to GND lines.
73	A16	O	Chip enable setting terminal for S RAM	Not used(pull down to GND lines.)
74	A17	O	Chip enable setting terminal for S RAM	
75	RAMOK	O	Pickup check judging terminal for production	Not used(N.C.)
76	ELVADJ	I	Mechanism deck ascent/descent position terminal	Not used(pull up to D 5V lines.)
77	RD	O	Read-out to S RAM control output	
78	WR	O	Write to S RAM control output	
79	WAIT	I	Waiting time insertion input when accessing S RAM	Not used(pull down to GND lines.)
80	ASTB	O	Chip selection to S RAM	Not used(N.C.)
81	VDD	-	Positive power supply connection terminal	Connected to D 5V lines.
82	PUSEL	I	Pickup type select terminal	Not used(pull up to D 5V lines.)
83	REQH	I	Communication request from H/U	"Lo" : Communication requested
84	SPLO+	O	Spindle/Loading control terminal	
85	SPLO-	O	Spindle/Loading control terminal	
86	ELV+	O	Mechanism deck ascent/descent terminal	
87	ELV-	O	Mechanism deck ascent/descent terminal	
88	SIM1	I	Destination input 1	"Hi" : adapted for CD-TEXT "Lo" : not adapted for CD-TEXT
89	SEARCH	O	Search mode output	Not used(N.C.)
90	TEST1	I	Test mode terminal 1 for test mode	Not used(pull down to GND lines.)
91	TEST2	I	Test mode terminal 2 for test mode	Not used(pull down to GND lines.)
92	8/7V	O	Motor driver IC power voltage control output	"Hi" : 7V, "Lo" : 8.5V
93	EEPWR	I	EEPROM write mode terminal for production	Not used(pull down to GND lines.)
94	TEST/VPP	I	Flash ROM program mode terminal	Not used(connected to GND lines.)
95	SRVSEL	I	Servo active mode terminal (no mechanism movement)	Not used(pull down to GND lines.)
96	SLNSA	I	Sled non-sensitive area ON/OFF terminal	Not used(pull down to GND lines.)
97	SDA	I/O	Data input/output with EEPROM	
98	SCL	O	Clock output to EEPROM	
99	PON	O	PON output	"Lo" : AVR & LPS POWER ON
100	ARMSW	I	Arm switch input	"Hi" : Arm switch ON

# KDC-C517FM, C717/Y

## MICROCOMPUTER'S TERMINAL DESCRIPTION

### ●IC2 (RF MODULATOR UNIT)

Pin No.	Pin Name	I/O	Description	Processing Operation
1	XIN	I	Main clock resonator connection terminal	
2	TEST2	I	Test mode terminal 2 for test mode	Not used(pull down to GND lines.)
3, 4	PG3, PG2	I		Not used(pull down to GND lines.)
5	PG1	I		Not used(pull up to +5v lines.)
6	PG0	I		Not used(pull down to GND lines.)
7-9	PH3-PH1	O		Not used(N.C.)
10	PH0 MUTE1	O		Not used(N.C.)
11	PF3 MUTE0	O		Not used(N.C.)
12	PF2 REQ $\bar{C}$	I	Communication request input form CH	"Lo" : Communication requested
13	PF1 REQ $\bar{H}$	O	Communication request output to CH	"Lo" : Communication requested
14	PF0 CHCON	O	Control output to CH	"Hi" : Operation mode, "Lo" : Standby mode
15	PE3 DATA IN	I	Data input from CH	
16	PE2 DATA OUT	O	Data output to CH	
17	PE1 SCK	O	Clock output to CH	
18	PE0	O		Not used(N.C.)
19	PD3 DATA OUT	O	Data output to LCD	
20	PD2 CLK	O	Clock output to LCD	
21	PD1 RST	O	Reset output to LCD	"Lo" : Reset
22	PD0 CE	O	CE output to LCD	
23-25	PC3-PC1			Not used(N.C.)
26	PC0 SEPA	O	Separation select output	"Hi" : Mode1, "Lo" : Mode2
27, 28	PB3, PB2	O		Not used(N.C.)
29	PB1 GAIN1	O	GAIN1 output	"Hi" : Level 1/3, "Lo" : Level 2/4
30	PB0 GAIN2	O	GAIN2 output	"Hi" : Level 3/4, "Lo" : Level 1/2
31	VDD+5V	-	Positive power supply connection terminal	Connected to +5V lines.
32	PA3 DATA IN	I	Data input from LCD	
33-35	PA2-PA0	I		Not used(connected to GND lines.)
36	PI31 S28	O		Not used(N.C.)
37	PI21 S27	O		Not used(N.C.)
38	PI11 S26	O		Not used(N.C.)
39	PI01 S25	O		Not used(N.C.)
40-58	S24-S6	O		Not used(N.C.)
59	ALC LOW S5	O		Not used(N.C.)
60	MUTE S4	O	Mute output	"Hi" : POWER OFF mode, "Lo" : POWER ON mode
61	SEP ATT S3	O	Separation attenuator output	"Hi" : Mode2, "Lo" : Mode1
62	RELAY S2	O	Relay SW control	"Hi" : RF modular output, "Lo" : Vehicle antenna output
63	P ON S1	O	P ON output	"Hi" : RF modulator circuit is active.
64, 65	COM2, COM1	O		Not used(N.C.)
66	REMO INT	I	Remote control sensor input	

# KDC-C517FM, C717/Y

## MICROCOMPUTER'S TERMINAL DESCRIPTION

Pin No.	Pin Name	I/O	Description	Processing Operation
67	HOLD	I	Hold input	"Lo" : Microprocessor stop
68	RES	I		Not used(pull up to +5V lines.)
69	AOI	I		Not used(pull down to GND lines.)
70	HCTR	I		Not used(pull down to GND lines.)
71	LCTR	I		Not used(pull down to GND lines.)
72	SNS	I		Not used(pull down to GND lines.)
73	VDD	-	Positive power supply connection terminal	Connected to +5V lines.
74	FMIN	I	FM input	
75	AMIN	I	AM input	Not used(pull down to GND lines.)
76	VSS	-	Ground connection terminal	Connected to GND lines.
77	EO1	O	FM frequency control output	
78	EO2	O		Not used(N.C.)
79	TEST1	I	Test mode terminal 1 for test mode	Not used(pull down to GND lines.)
80	XOUT	-	Main clock resonator connection terminal	



# KDC-C517FM, C717/Y

## ADJUSTMENT

### RF MODULATOR UNIT

1. DC balance adjustment (VR301)

While observing the waveform with an oscilloscope at pin 13 of IC301, adjust VR301 to minimize the waveform level.

2. PLL control voltage adjustment (VC301)

First set the transmission frequency to \*87.9 MHz with the commander, then adjust VC301 so that the DC Voltage at the + pole of C317, measured using a multi-meter or digital tester, is + 3V ( $\pm 0.1$  V).

\*NOTE: E type is 87.7MHz.

3. Modulation level adjustment (VR303)

The method uses a standard receiver or tuner.

Adjust VR303 so that the output level from the standard receiver or tuner is as specified.

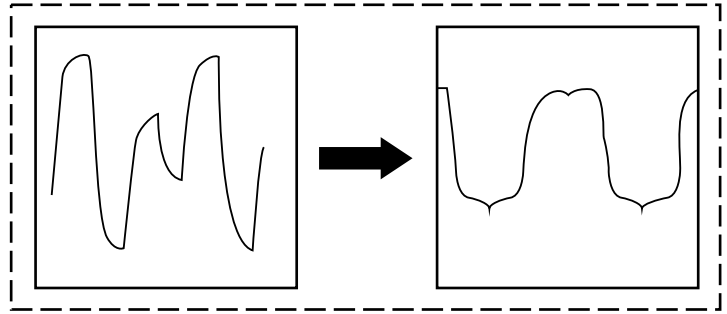

### L.P.S. initial position adjustment procedure

1. Connect the changer to the H/U.
2. While holding the magazine eject button of the changer, press the reset button of the H/U.
3. After about 3 seconds, release the magazine eject button.
4. Press the SRC button of the H/U to enter the CD-CH mode, and the H/U's display section indicates "E-88".
5. Move the mechanism deck to around the 1st stage by pressing the DISC- or DISC+ button.
6. Insert the adjustment tool (W05-0635-00) into the tool hole on the changer mechanism.
7. Then press the DISC+ button to move the mechanism deck until the mechanism's slider hits the adjustment tool.
8. When the motor locks (stops), press the REPEAT key of the H/U.

When the REPEAT key is pressed, the

mechanism moves automatically to the 1st stage and the initial position adjustment completes. (The data is written in the EEPROM at this time.)

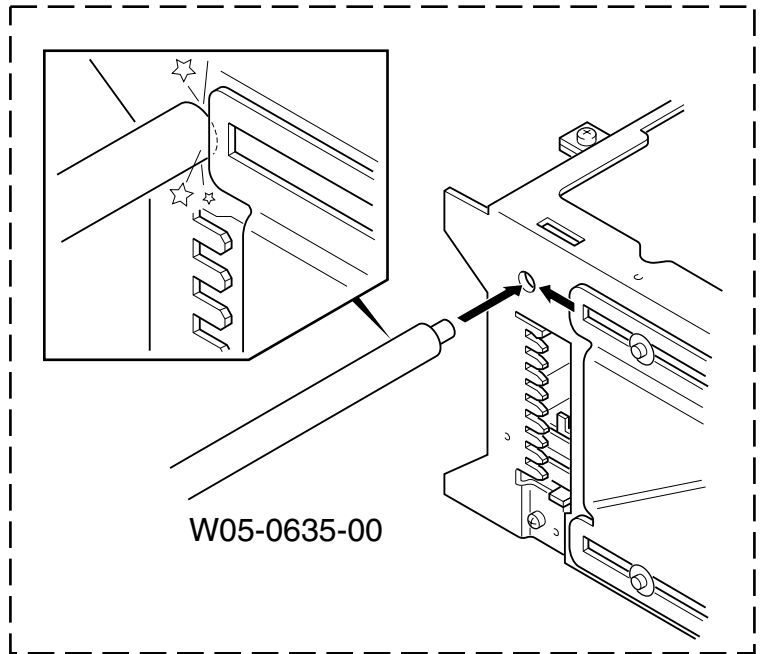

# PC BOARD (COMPONENT SIDE VIEW)

X13-9840-00 (J74-1100-02)

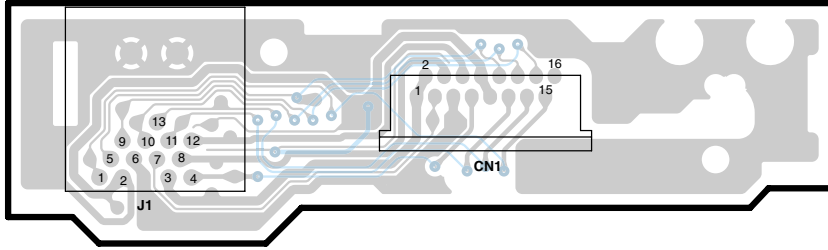

X16-1010-00 (J74-1153-01)

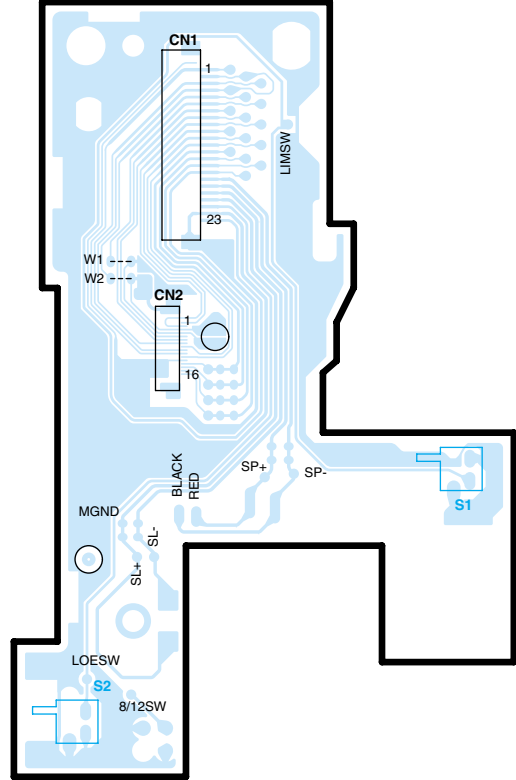

# (FOIL SIDE VIEW)

X13-9840-00 (J74-1100-02)

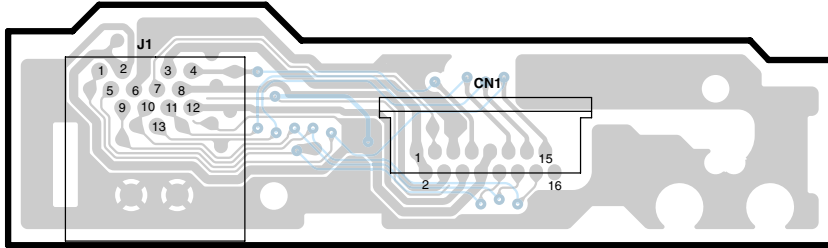

X16-1010-00 (J74-1153-01)

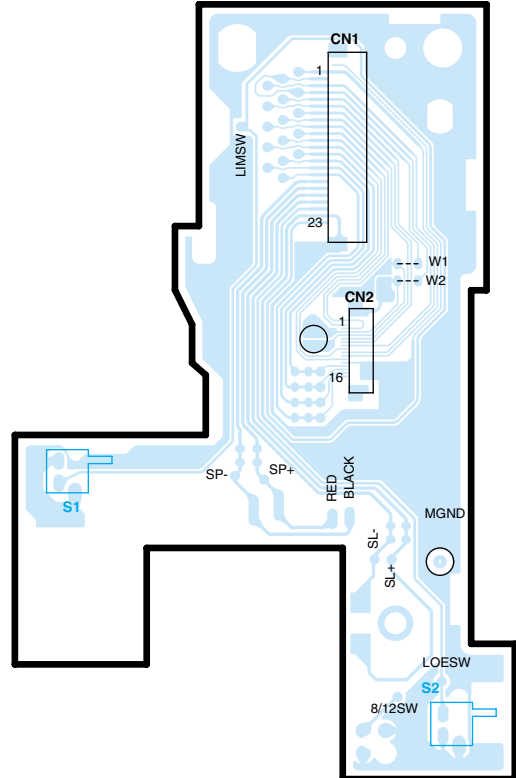

10 Refer to the schematic diagram for the values of resistors and capacitors.

# PC BOARD (COMPONENT SIDE VIEW)

X32-5090-0X (J74-1127-21)

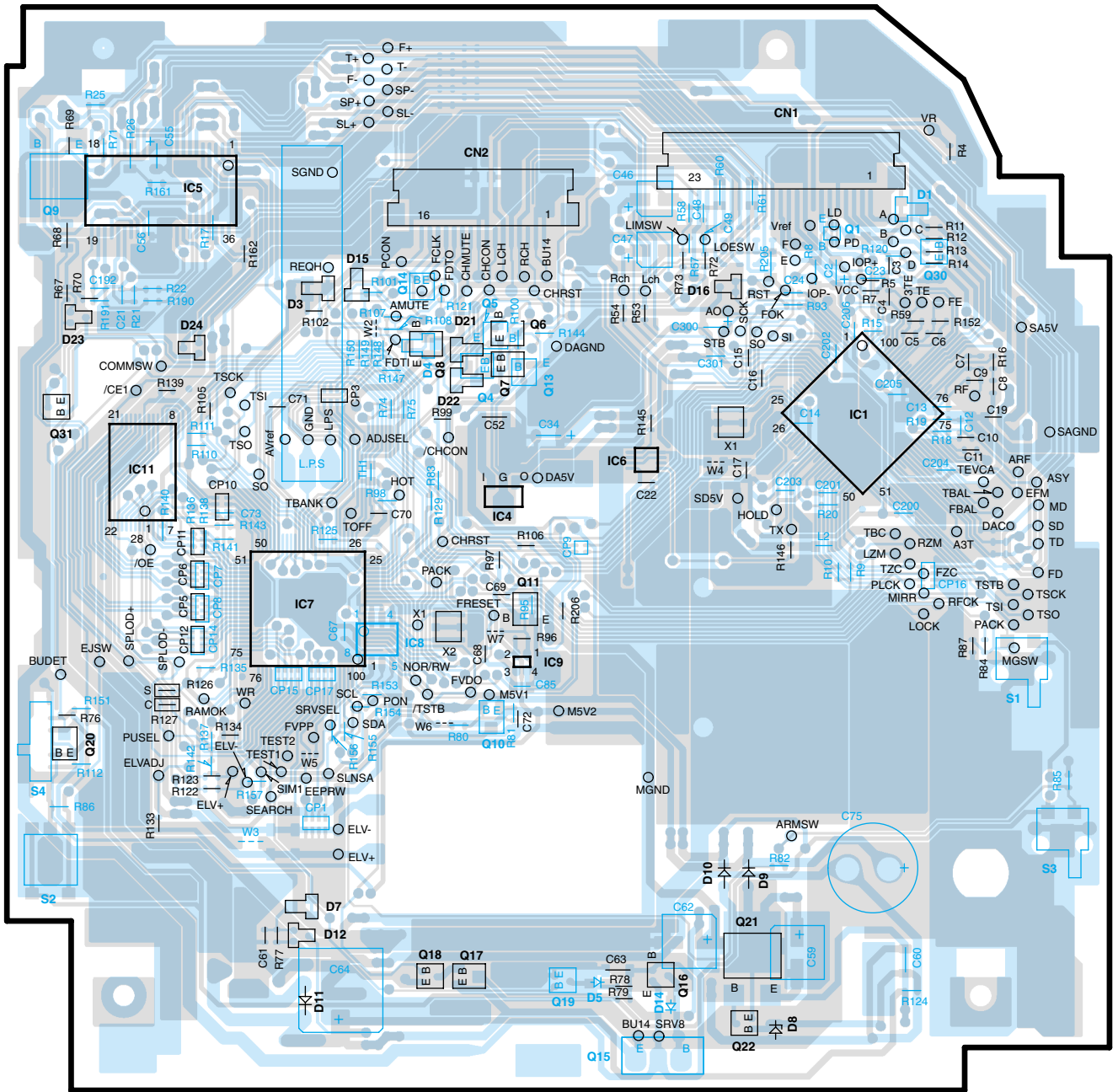

X32-5090-0X

IC	1	4	5	7	8	9	11																				
Q								1	4	5	6	7	8	9	10	11	13	14	16	17	18	19	20	21	22	30	31
address	3I	4H	2F	4G	4G	4H	3F	2I	3H	3H	3H	3H	3G	2F	4H	4H	3H	3G	5H	5H	5G	5H	4F	5I	6I	3I	3F

# PC BOARD (FOIL SIDE VIEW)

X32-5090-0X (J74-1127-21)

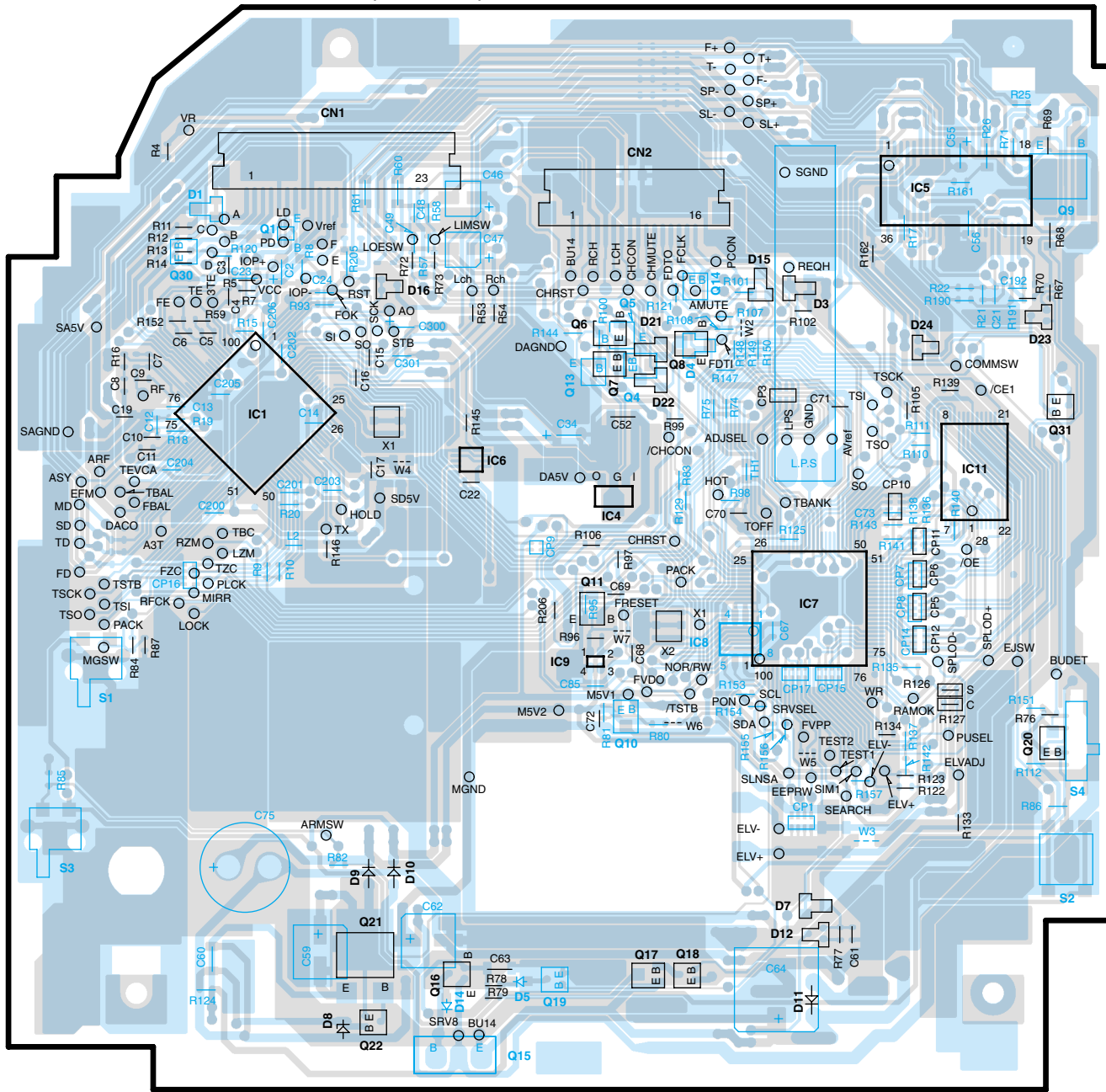

X32-5090-0X

IC	1	4	5	7	8	9	11																				
Q		1	4	5	6	7	8	9	10	11	13	14	16	17	18	19	20	21	22	30	31						
address	3L	4M	2O	4N	4N	4M	3O	2L	3M	3M	3M	3M	3N	2O	4M	4M	3M	3N	5M	5M	5N	5M	5O	5L	6L	3L	3O

# PC BOARD (COMPONENT SIDE VIEW)

## RF MODULATOR

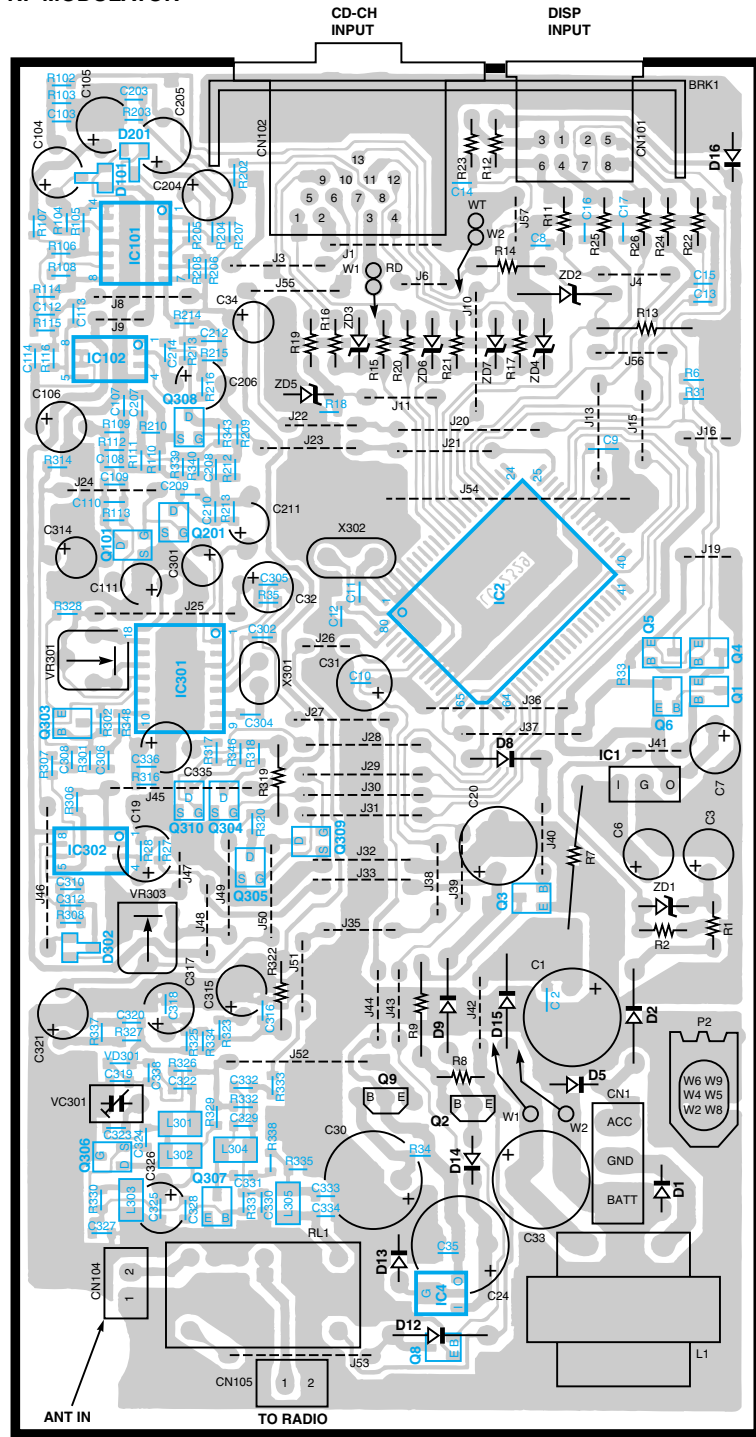

IC	Q
1	4R
2	3R
4	5Q
101	2P
102	2P
301	3P
302	4P
1	3R
2	5Q
3	4R
4	3R
5	3R
6	4R
8	6Q
9	5Q
101	3P
201	3Q
303	4P
304	4Q
305	4Q
306	5P
307	5Q
308	2Q
309	4Q
310	4Q

# (FOIL SIDE VIEW)

## RF MODULATOR

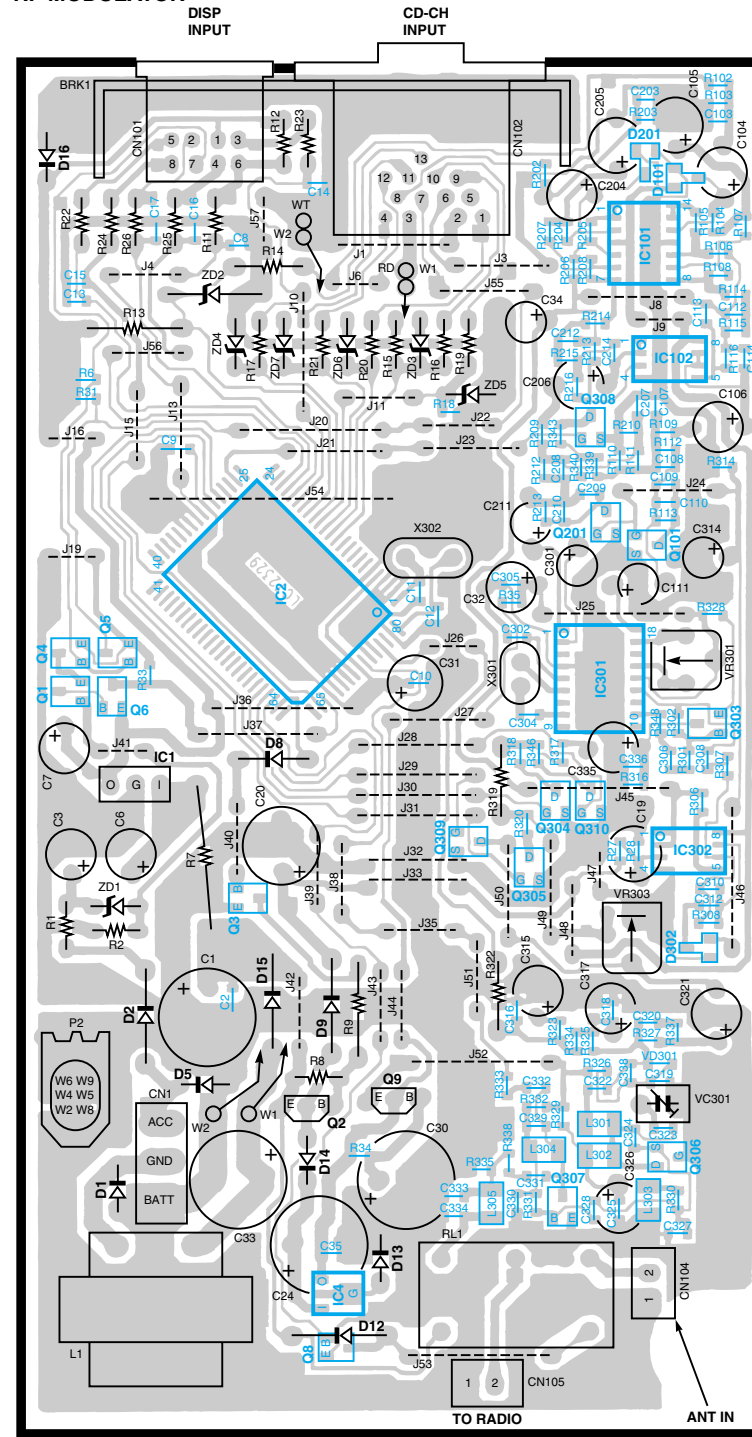

IC	Q
1	4U
2	3V
4	5V
101	2W
102	2W
301	3W
302	4W
1	3U
2	5V
3	4V
4	3U
5	3U
6	3U
8	6V
9	5V
101	3W
201	3W
303	4W
304	4W
305	4W
306	5W
307	5W
308	2W
309	4V
310	4W

## DISPLAY UNIT

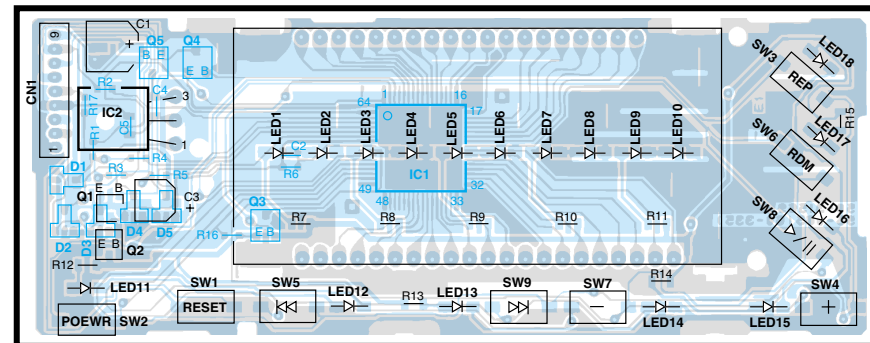

IC	Q
1	7S
2	6Q
1	7Q
2	7R
3	7R
4	6R
5	6R

## DISPLAY UNIT

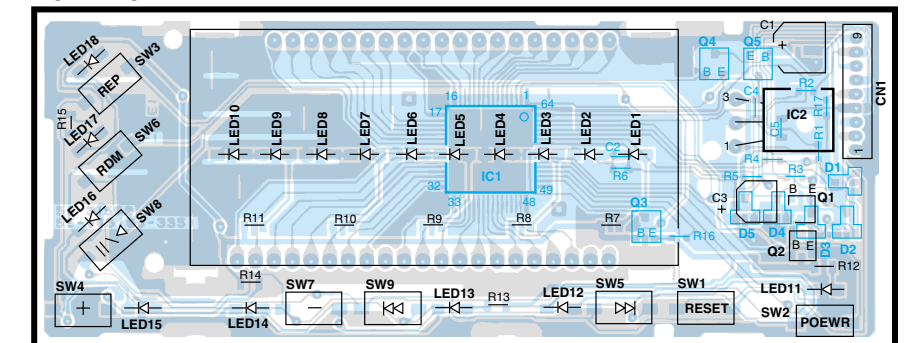

IC	Q
1	7X
2	6Y
1	7Y
2	7Y
3	7X
4	6X
5	6Y

Refer to the schematic diagram for the values of resistors and capacitors.

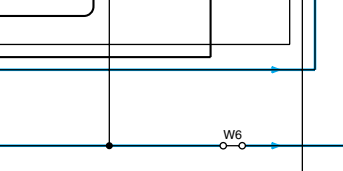
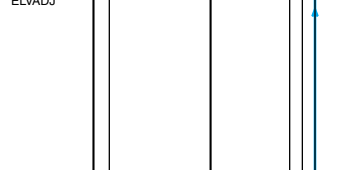
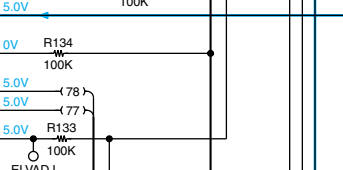
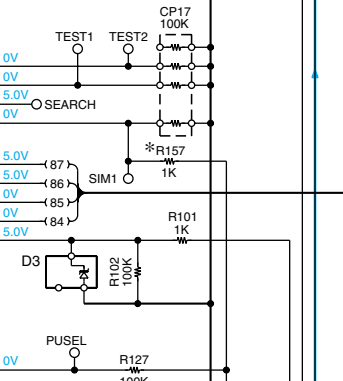
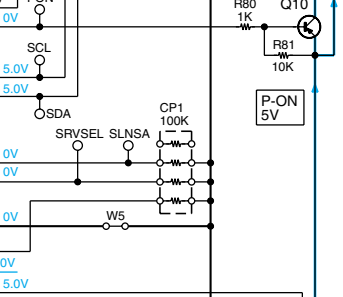
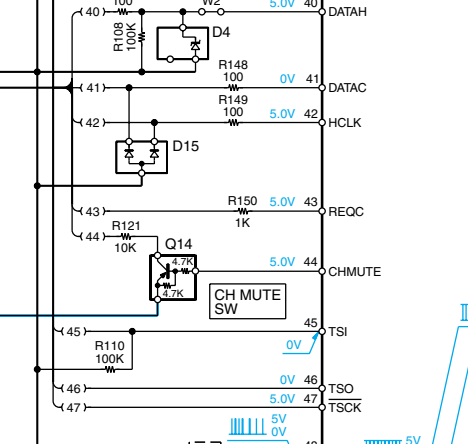
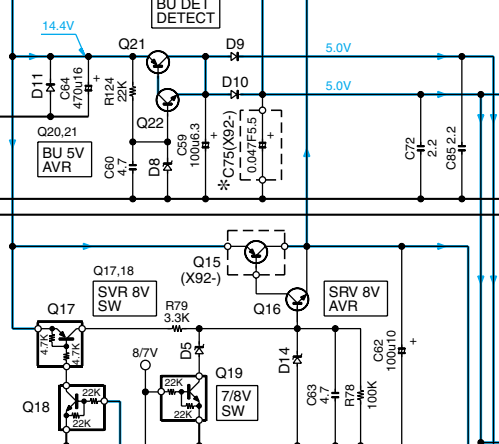
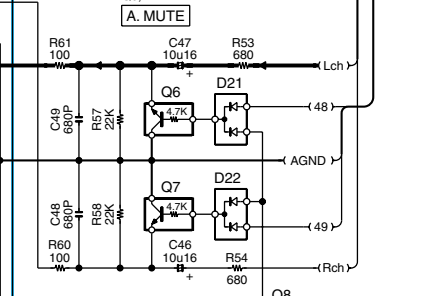
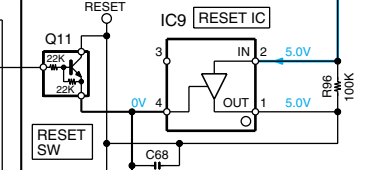
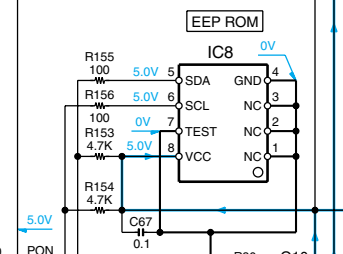
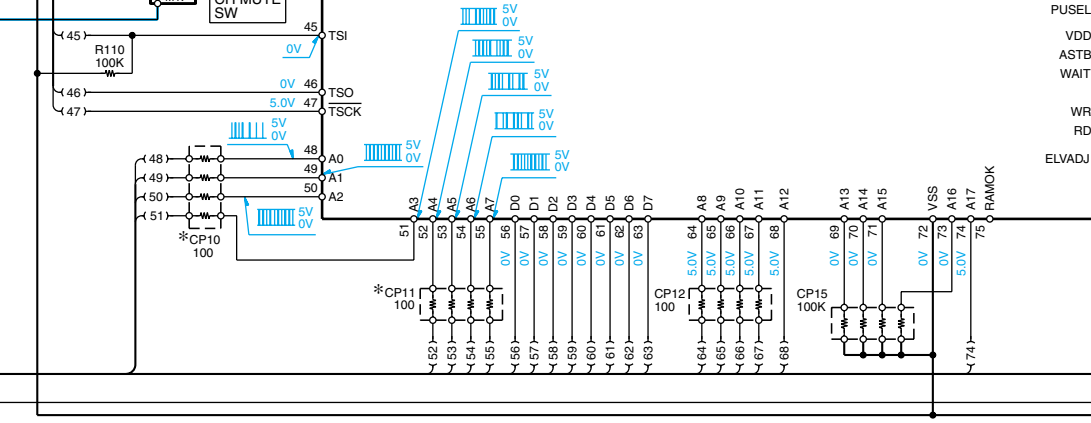
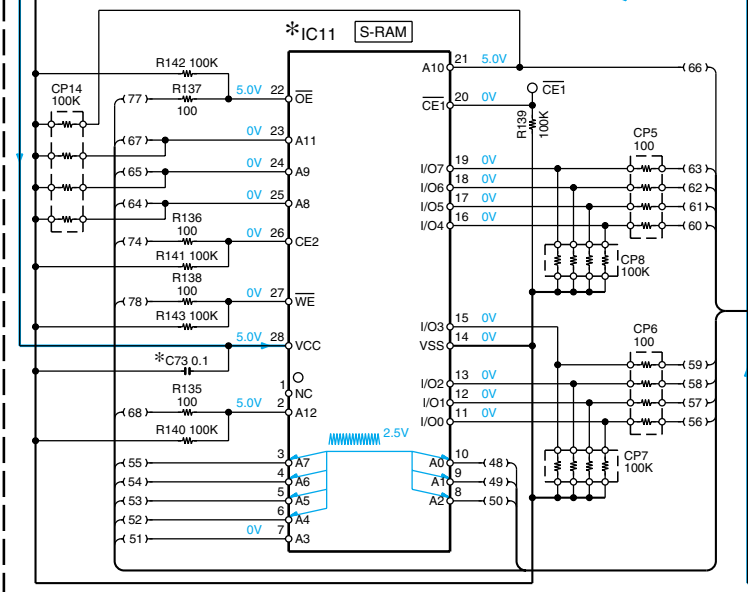
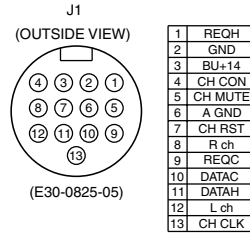
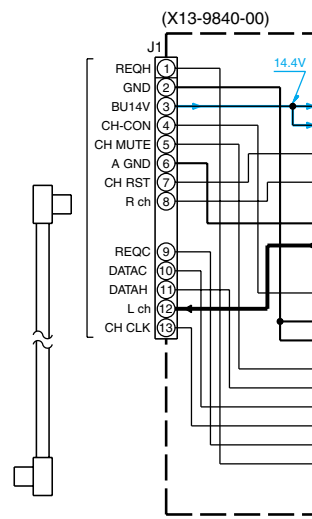
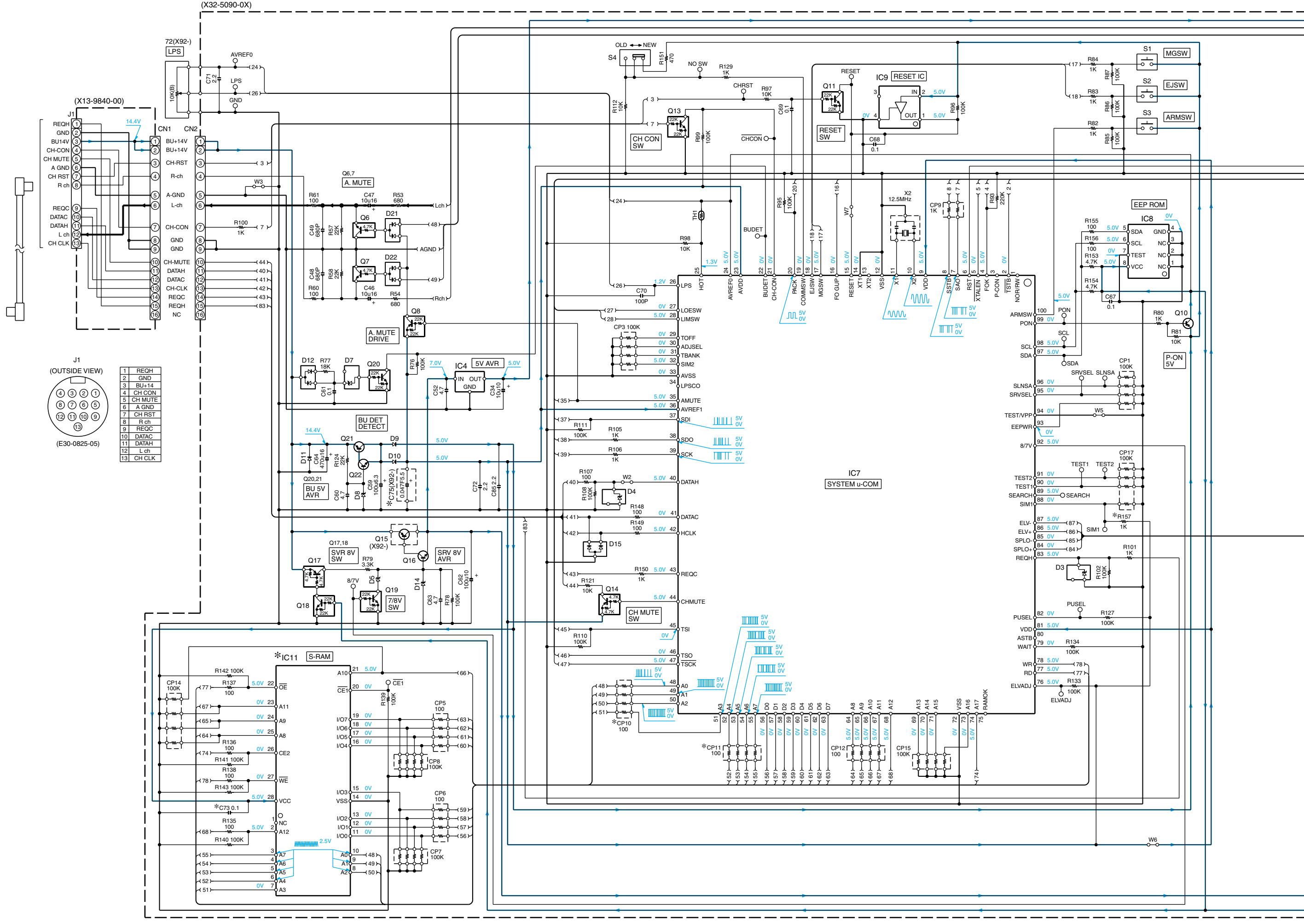

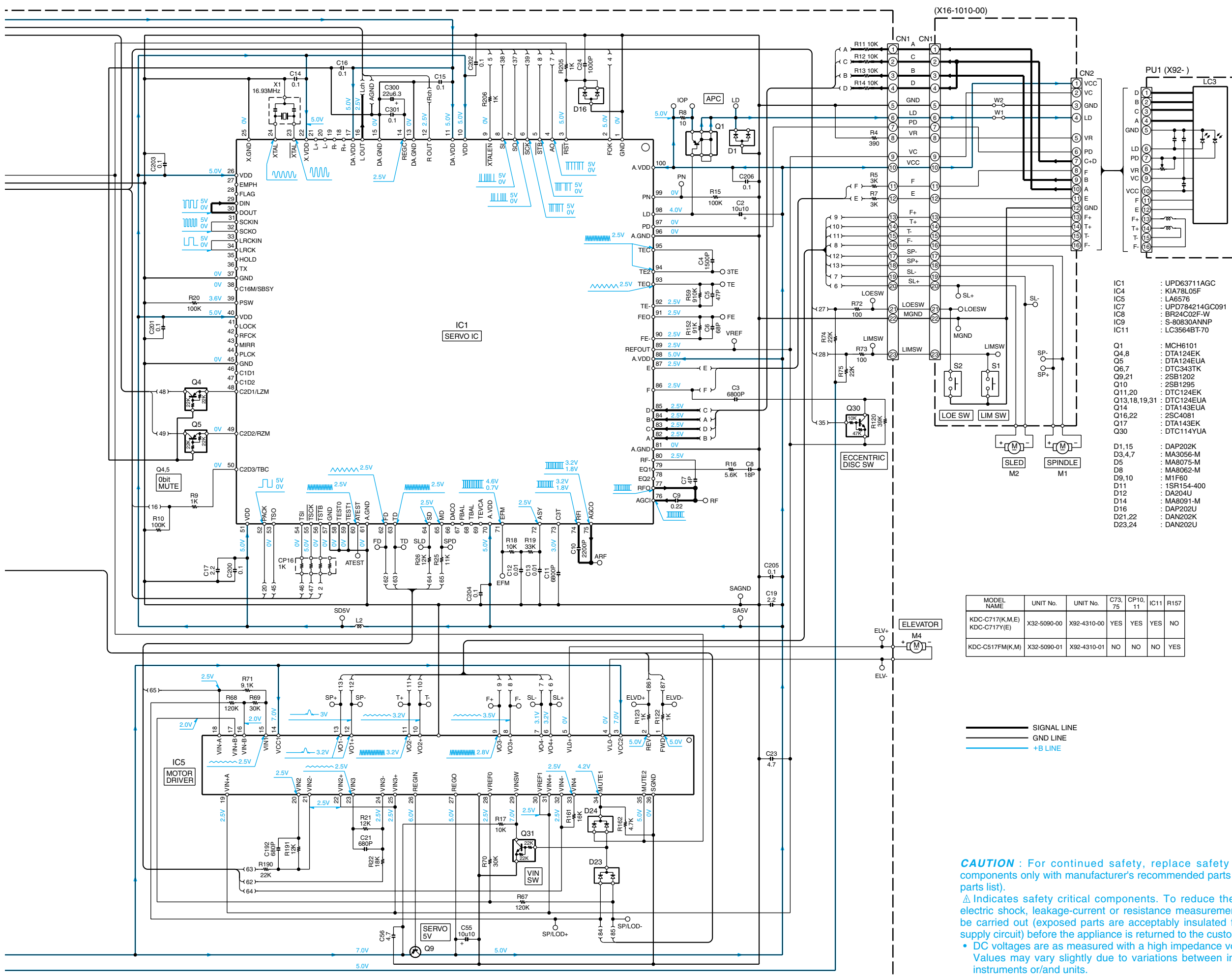

- IC1 : UPD63711AGC
- IC4 : KIA78L05F
- IC5 : LA6576
- IC7 : UPD784214GC091
- IC8 : BR24C02F-W
- IC9 : S-80830ANNP
- IC11 : LC3564BT-70
- Q1 : MCH6101
- Q4,8 : DTA124EK
- Q5 : DTA124EUA
- Q6,7 : DTC343TK
- Q9,21 : 2SB1202
- Q10 : 2SB1295
- Q11,20 : DTC124EK
- Q13,18,19,31 : DTC124EUA
- Q14 : DTA143EUA
- Q16,22 : 2SC4081
- Q17 : DTA143EK
- Q30 : DTC114YUA
- D1,15 : DAP202K
- D3,4,7 : MA3056-M
- D5 : MA8075-M
- D8 : MA8062-M
- D9,10 : M1F60
- D11 : 1SR154-400
- D12 : DA204U
- D14 : MA8091-M
- D16 : DAP202U
- D21,22 : DAN202K
- D23,24 : DAN202U

MODEL NAME	UNIT No.	UNIT No.	C73, 75	CP10, 11	IC11	R157
KDC-C717(K,M,E)	X32-5090-00	X92-4310-00	YES	YES	YES	NO
KDC-C717(Y,E)	X32-5090-01	X92-4310-01	NO	NO	NO	YES

——— SIGNAL LINE  
 ——— GND LINE  
 ——— +B LINE

**CAUTION :** For continued safety, replace safety critical components only with manufacturer's recommended parts (refer to parts list).

⚠ Indicates safety critical components. To reduce the risk of electric shock, leakage-current or resistance measurements shall be carried out (exposed parts are acceptably insulated from the supply circuit) before the appliance is returned to the customer.

- DC voltages are as measured with a high impedance voltmeter. Values may vary slightly due to variations between individual instruments or/and units.

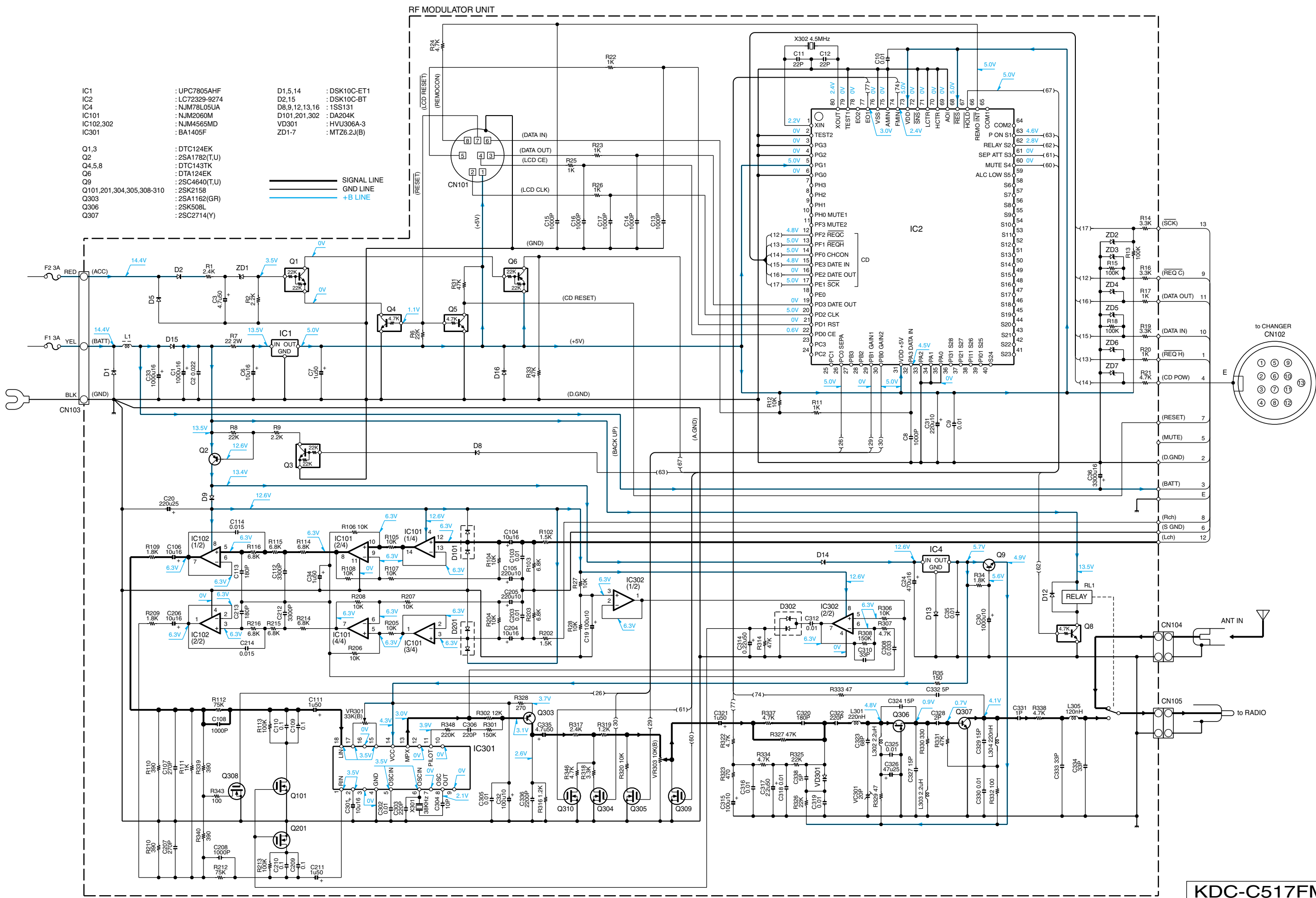

- |           |                |               |              |
|-----------|----------------|---------------|--------------|
| IC1       | : UPC7805AHF   | D1,5,14       | : DSK10C-ET1 |
| IC2       | : LC72329-9274 | D2,15         | : DSK10C-BT  |
| IC4       | : NJM78L05UA   | D8,9,12,13,16 | : 1SS131     |
| IC101     | : NJM2060M     | D101,201,302  | : DA204K     |
| IC102,302 | : NJM4565MD    | VD301         | : HVU306A-3  |
| IC301     | : BA1405F      | ZD1-7         | : MTZ6.2J(B) |
- 
- |                          |                |
|--------------------------|----------------|
| Q1,3                     | : DTC124EK     |
| Q2                       | : 2SA1782(T,U) |
| Q4,5,8                   | : DTC143TK     |
| Q6                       | : DTA124EK     |
| Q9                       | : 2SC4640(T,U) |
| Q101,201,304,305,308-310 | : 2SK2158      |
| Q303                     | : 2SA1162(GR)  |
| Q306                     | : 2SK508L      |
| Q307                     | : 2SC2714(Y)   |

SIGNAL LINE  
 GND LINE  
 +B LINE

**KDC-C517FM**  
**KDC-C717/Y**  
**KENWOOD**

**CAUTION:** For continued safety, replace safety critical components only with manufacturer's recommended parts (refer to parts list).  
 ⚠ Indicates safety critical components. To reduce the risk of electric shock, leakage-current or resistance measurements shall be

• DC voltages are as measured with a high impedance voltmeter. Values may vary slightly due to variations between individual instruments or/and units.



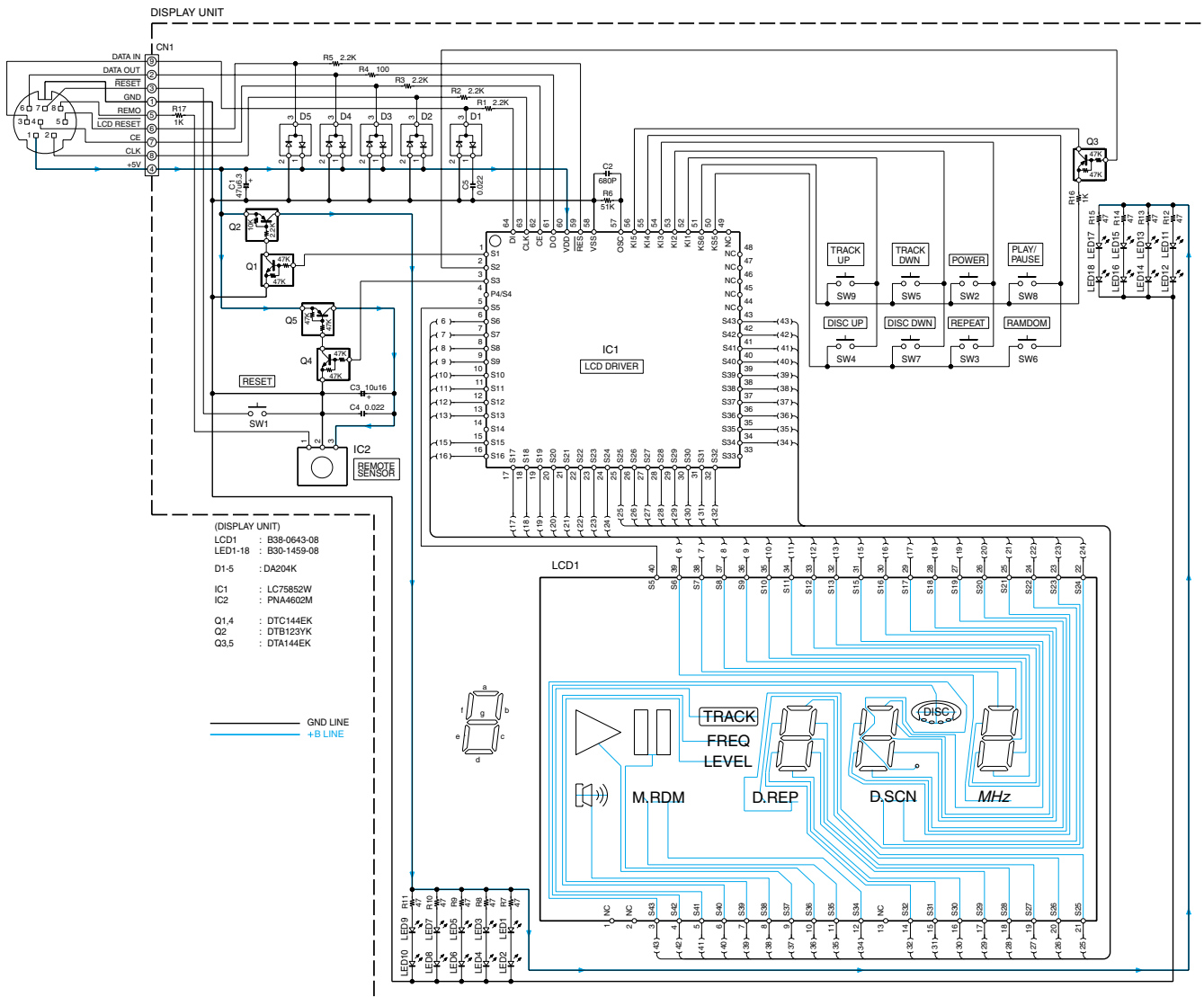

**CAUTION :** For continued safety, replace safety critical components only with manufacturer's recommended parts (refer to parts list).  
 ⚠ Indicates safety critical components. To reduce the risk of electric shock, leakage-current or resistance measurements shall be carried out (exposed parts are acceptably insulated from the supply circuit) before the appliance is returned to the customer.  
 • DC voltages are as measured with a high impedance voltmeter. Values may vary slightly due to variations between individual instruments or/and units.

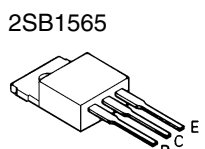

DTA124EK  
DTA143EK  
DTA144EK  
DTB123YK  
DTC114YUA  
DTC124EK  
DTC143TK

DTC144EK  
DTC343TK  
2SA1162  
2SB1295  
2SC2714

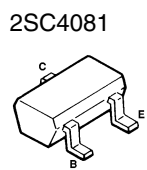

DTA124EUA  
DTA143EUA  
DTC124EUA

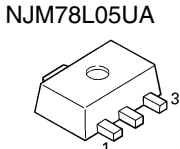
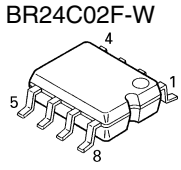
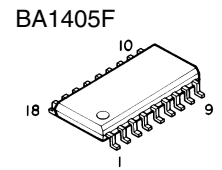
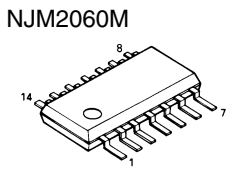
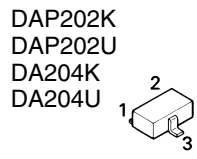
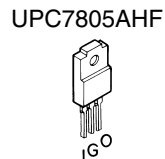
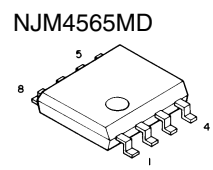

# KDC-C517FM, C717/Y

## EXPLODED VIEW (MECHANISM)

A	φ2x3.5	: N09-4126-05
B	φ2x2.5(BLK)	: N09-4288-05
C	φ2x5	: N86-2005-46
D	φ1.7x1.5(BLK)	: N09-4189-05
E	φ2x6	: N09-4154-05
F	M1.7x3	: N09-4181-05
G	M1.7x2.2	: N39-1722-46
H	φ2x3.5	: N09-4349-05
J	WASHER φ3.8	: N19-2105-14
K	WASHER φ4	: N19-2058-04
L	WASHER φ3.8	: N19-2080-14
M	WASHER φ3.5	: N19-2028-04

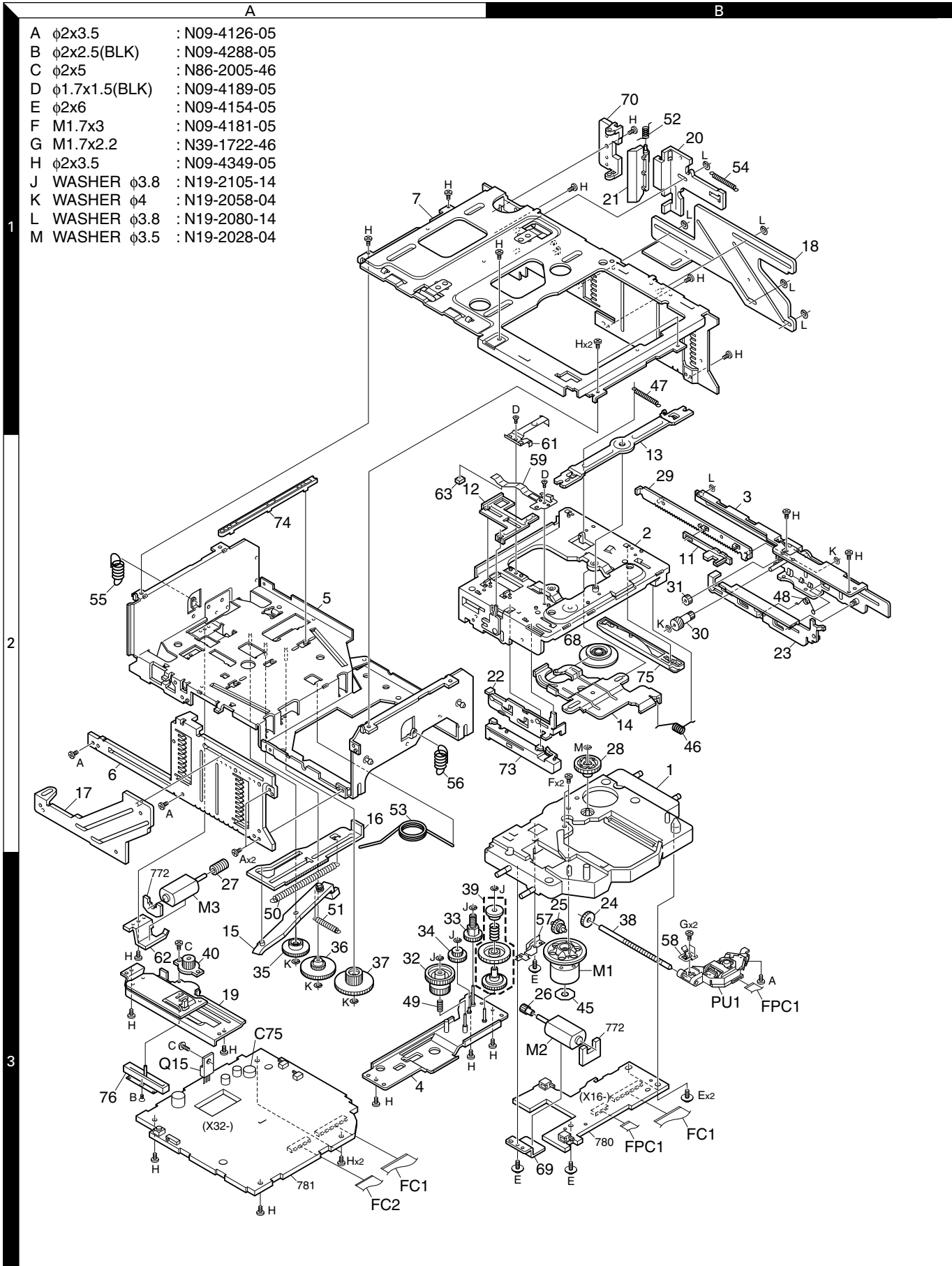

# KDC-C517FM, C717/Y

## EXPLODED VIEW (UNIT)

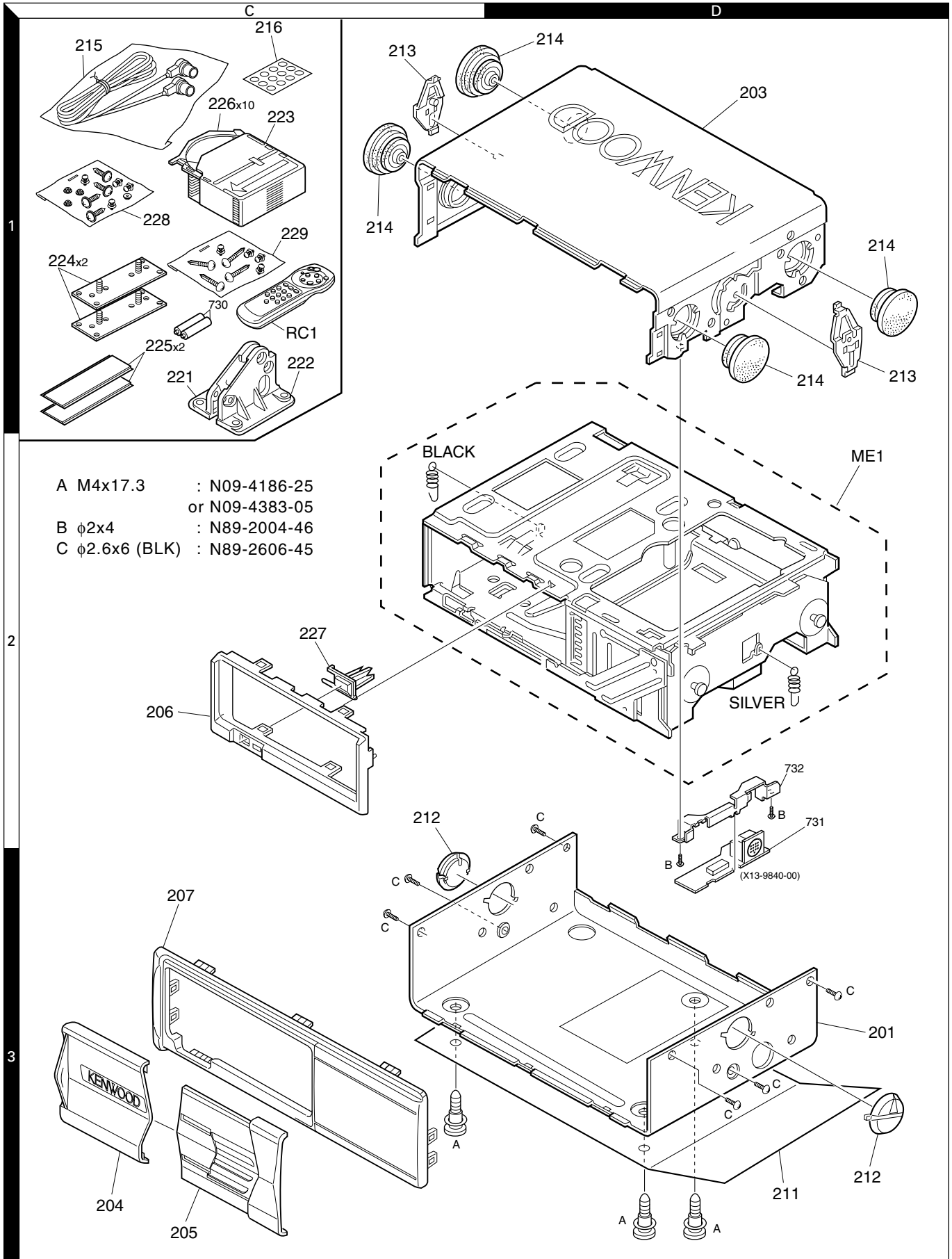

Parts with the exploded numbers larger than 700 are not supplied.

# KDC-C517FM, C717/Y

## EXPLODED VIEW (RF MODULATOR)

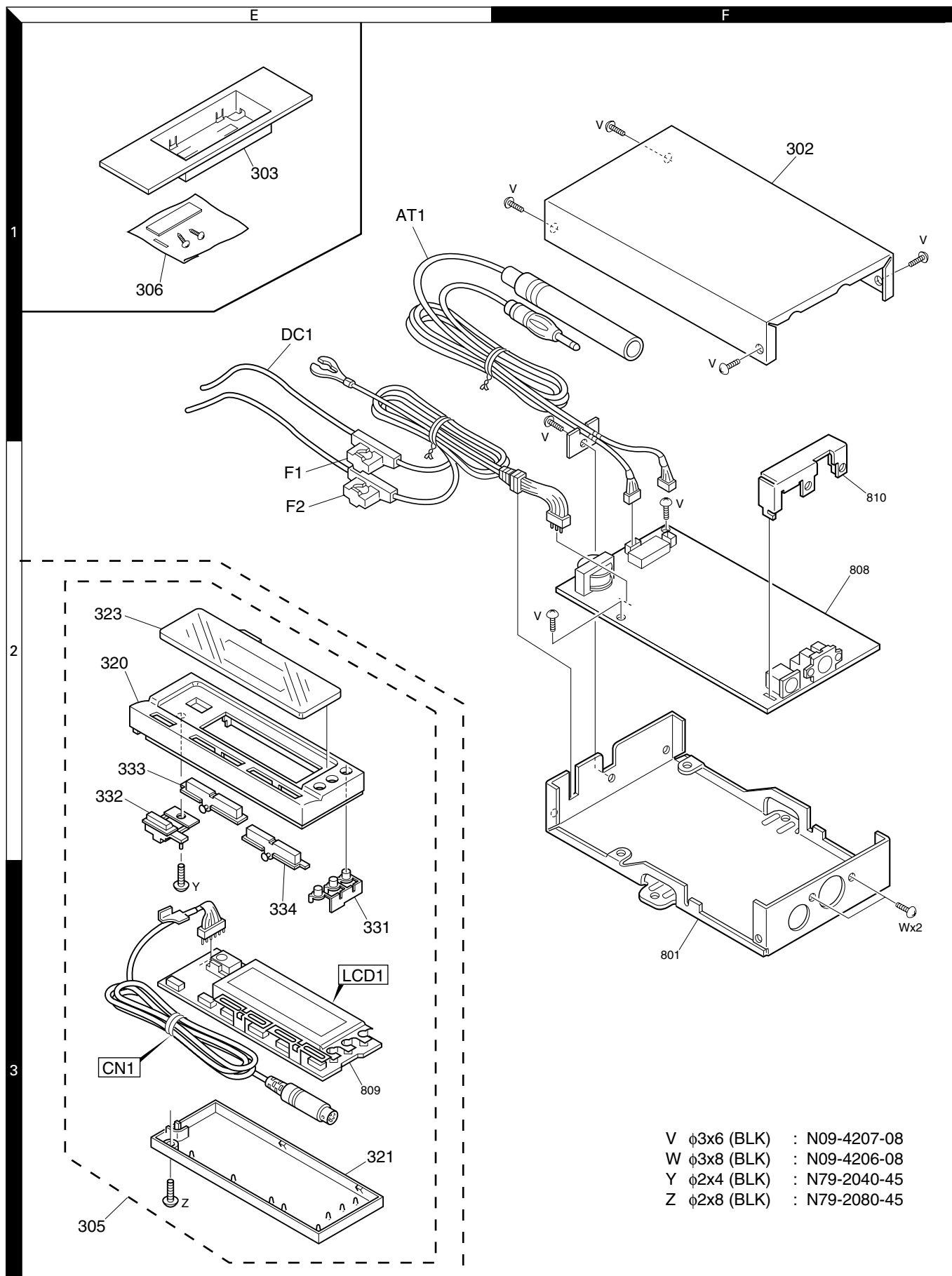

- |   |            |   |             |
|---|------------|---|-------------|
| V | φ3x6 (BLK) | : | N09-4207-08 |
| W | φ3x8 (BLK) | : | N09-4206-08 |
| Y | φ2x4 (BLK) | : | N79-2040-45 |
| Z | φ2x8 (BLK) | : | N79-2080-45 |

# KDC-C517FM, C717/Y

## PARTS LIST

\* New Parts

Parts without **Parts No.** are not supplied.

Les articles non mentionnes dans le **Parts No.** ne sont pas fournis.

Teile ohne **Parts No.** werden nicht geliefert.

Ref. No.	A d d	N e w	Parts No.	Description	Dest inati on
<b>KDC-C517FM,C717/Y</b>					
201	3D	*	A10-4735-01	CHASSIS	K2M2E2
201	3D	*	A10-4735-01	CHASSIS	K3M3
201	3D	*	A10-4841-01	CHASSIS	E
203	1D	*	A01-2726-11	METALLIC CABINET	K2M2E2
203	1D	*	A01-2726-11	METALLIC CABINET	K3M3
203	1D	*	A01-2748-01	METALLIC CABINET	E
204	3C	*	A21-4047-12	DRESSING PANEL	
205	3C	*	A21-4048-12	DRESSING PANEL	
206	2C	*	A22-2259-12	SUB PANEL	E
206	2C	*	A22-2837-02	SUB PANEL	K2M2E2
206	2C	*	A22-2837-02	SUB PANEL	K3M3
207	3C	*	A64-2324-01	PANEL	E
207	3C	*	A64-2324-01	PANEL	K2M2E2
207	3C	*	A64-2347-01	PANEL	K3M3
RC1	1C		A70-0896-05	REMOTE CONTROLLER ASSY(RC-503)	K3M3
211	3D		B58-1275-04	CAUTION CARD	K2M2E2
211	3D		B58-1275-04	CAUTION CARD	K3M3
211	3D		B58-1314-04	CAUTION CARD (TRANSPORTATIO)	E
-			B46-0100-50	WARRANTY CARD	
-			B46-0182-14	ID CARD	E2E
-			B58-1236-04	CAUTION CARD (CORD)	K2M2E2
-			B58-1236-04	CAUTION CARD (CORD)	K3M3
-			B58-1273-04	CAUTION CARD (P1,PRA,A6,1)	K3M3
-			B58-1285-04	CAUTION CARD (O-N FORMAT SW)	K2M2K3
-			B58-1285-04	CAUTION CARD (O-N FORMAT SW)	M3
-			B58-1289-04	CAUTION CARD (O-N FORMAT SW)	E2
-			B58-1312-04	CAUTION CARD (13PIN CABLE)	E
-			B58-1313-04	CAUTION CARD (O-N FORMAT SW)	E
-		*	B64-1771-00	INST. MANUAL(GER,DUT,ITA)	E
-		*	B64-1797-00	INST. MANUAL(ENG,FRE,SPA,POR)	K2E
-		*	B64-1798-00	INST. MANUAL(ENG,FRE,SPA,POR)	K3
-		*	B64-1801-00	INST. MANUAL(ENG,CHI)	M2
-		*	B64-1802-00	INST. MANUAL(ARABIC)	M2
-		*	B64-1803-00	INST. MANUAL(ENG,CHI)	M3
-		*	B64-1804-00	INST. MANUAL(ARABIC)	M3
-		*	B64-1806-00	INST. MANUAL(ENG,RUS,POL)	E2
-		*	B64-1807-00	INST. MANUAL(CZE,HUN,CRO)	E2
212	3D	*	D10-4204-13	ARM	E
212	3D	*	D10-4515-03	ARM	K2M2E2
212	3D	*	D10-4515-03	ARM	K3M3
213	1C		D10-4033-14	LEVER	E
213	1C	*	D10-4516-04	LEVER	K2M2E2
213	1C	*	D10-4516-04	LEVER	K3M3
214	1C	*	D39-0242-05	DAMPER	
215	1C		E30-4291-05	CORD WITH PLUG	K2M2E2
215	1C		E30-4291-05	CORD WITH PLUG	K3M3
215	1C		E30-4711-05	CORD WITH PLUG	E
215	1C	*	E30-4954-05	CORD WITH PLUG	K2M2E2
215	1C	*	E30-4954-05	CORD WITH PLUG	K3M3
215	1C	*	E30-4955-05	CORD WITH PLUG	E
216	1C		F19-1303-04	BLIND PLATE	

Ref. No.	A d d	N e w	Parts No.	Description	Dest inati on
-		*	H02-0822-03	INNER CARTON CASE	E
-		*	H02-0827-03	INNER CARTON CASE	K2M2E2
-		*	H02-0827-03	INNER CARTON CASE	K3M3
-		*	H10-4637-02	POLYSTYRENE FOAMED FIXTURE	E
-		*	H10-4729-02	POLYSTYRENE FOAMED FIXTURE	K2M2E2
-		*	H10-4729-02	POLYSTYRENE FOAMED FIXTURE	K3M3
-		*	H25-0337-04	PROTECTION BAG (180X300X0.03)	
-		*	H25-1115-04	PROTECTION BAG	
-		*	H54-1890-04	ITEM CARTON CASE	E
-		*	H54-1947-04	ITEM CARTON CASE	K2
-		*	H54-1948-04	ITEM CARTON CASE	K3
-		*	H54-1950-04	ITEM CARTON CASE	M2
-		*	H54-1966-04	ITEM CARTON CASE	M3
-		*	H54-1968-04	ITEM CARTON CASE	E2
221	1C		J19-4710-13	BRACKET (L)	E
221	1C	*	J19-5018-03	BRACKET (L)	K2M2E2
221	1C	*	J19-5018-03	BRACKET (L)	K3M3
222	1C		J19-4711-13	BRACKET (R)	E
222	1C	*	J19-5019-03	BRACKET (R)	K2M2E2
222	1C	*	J19-5019-03	BRACKET (R)	K3M3
223	1C		J19-4940-02	HOLDER ASSY	E
223	1C	*	J19-5074-02	HOLDER ASSY	K2M2E2
223	1C	*	J19-5074-02	HOLDER ASSY	K3M3
224	1C		J21-9588-04	MOUNTING HARDWARE ASSY	M2M3
225	1C		J69-0506-04	ADHESIVE TAPE	M2M3
226	1C		J99-0604-21	TRAY	E
226	1C	*	J99-0612-01	TRAY	K2M2E2
226	1C	*	J99-0612-01	TRAY	K3M3
227	2C		K24-1770-04	KNOB	E
227	2C	*	K24-3629-04	KNOB	K2M2E2
227	2C	*	K24-3629-04	KNOB	K3M3
228	1C		N99-1628-15	SCREW SET	M2M3
229	1C		N99-1645-15	SCREW SET	K2E2E
229	1C		N99-1645-15	SCREW SET	K3
A	3D		N09-4186-25	STEPPED SCREW	E
A	3D		N09-4383-05	STEPPED SCREW	K2M2E2
A	3D		N09-4383-05	STEPPED SCREW	K3M3
B	2D		N89-2004-46	BINDING HEAD TAPTITE SCREW	
C	3D		N89-2606-45	BINDING HEAD TAPTITE SCREW	
ME1	2D	*	X92-4310-00	MECHANISM ASSY (CHM-1060)	K2M2E2
ME1	2D	*	X92-4310-00	MECHANISM ASSY (CHM-1060)	E
ME1	2D	*	X92-4310-01	MECHANISM ASSY (CHM-1061)	K3M3
<b>SUB-CIRCUIT UNIT (X13-9840-00)</b>					
CN1			E40-9555-05	FLAT CABLE CONNECTOR (16P)	
J1			E56-0825-05	CYLINDRICAL RECEPTACLE (13P)	
<b>SUB-CIRCUIT UNIT (X16-1010-00)</b>					
CN1			E40-9487-05	FLAT CABLE CONNECTOR (23P)	
CN2			E40-9536-05	FLAT CABLE CONNECTOR (16P)	
S1 ,2			S74-0811-05	MICRO SWITCH	
<b>CD PLAYER UNIT (X32-5090-0X)</b>					
C2			C92-0628-05	CHIP-TAN 10UF 10WV	
C3			CK73GB1H682K	CHIP C 6800PF K	

K2: KDC-C717  
K3: KDC-C517FM

M2: KDC-C717  
M3: KDC-C517FM

E: KDC-C717

E2: KDC-C717Y

△ indicates safety critical components.

# KDC-C517FM, C717/Y

## PARTS LIST

\*New Parts

Parts without **Parts No.** are not supplied.

Les articles non mentionnes dans le **Parts No.** ne sont pas fournis.

Teile ohne **Parts No.** werden nicht geliefert.

### CD PLAYER UNIT (X32-5090-0X)

Ref. No.	Ad	New	Parts No.	Description	Destination
C4			CK73GB1H152K	CHIP C 1500PF K	
C5			CC73GCH1H470J	CHIP C 47PF J	
C6			CC73GCH1H680J	CHIP C 68PF J	
C7			CC73GCH1H040C	CHIP C 4.0PF C	
C8			CC73GCH1H180J	CHIP C 18PF J	
C9			CK73GB1A224K	CHIP C 0.22UF K	
C10			CK73GB1H222K	CHIP C 2200PF K	
C11			CK73GB1H682K	CHIP C 6800PF K	
C12,13			CK73GB1H103K	CHIP C 0.010UF K	
C14-16			CK73GB1C104K	CHIP C 0.10UF K	
C17			CK73FB1A225K	CHIP C 2.2UF K	
C19			CK73FB1A225K	CHIP C 2.2UF K	
C21			CK73GB1H681K	CHIP C 680PF K	
C23			CK73EB1A475K	CHIP C 4.7UF K	
C24			CK73GB1H102K	CHIP C 1000PF K	
C34			C92-0628-05	CHIP-TAN 10UF 10WV	
C46,47			C92-1393-05	ELECTRO 10UF 16WV	
C48,49			CK73GB1H681K	CHIP C 680PF K	
C52			CK73EB1A475K	CHIP C 4.7UF K	
C55			C92-0628-05	CHIP-TAN 10UF 10WV	
C56			CK73EB1A475K	CHIP C 4.7UF K	
C59			C92-1390-05	ELECTRO 100UF 6.3WV	
C60			CK73EB1A475K	CHIP C 4.7UF K	
C61			CK73GB1C104K	CHIP C 0.10UF K	
C62			C92-1392-05	ELECTRO 100UF 10WV	
C63			CK73EB1A475K	CHIP C 4.7UF K	
C64			C92-1388-05	ELECTRO 470UF 16WV	
C67-69			CK73GB1C104K	CHIP C 0.10UF K	
C70			CC73GCH1H101J	CHIP C 100PF J	
C71,72			CK73FB1A225K	CHIP C 2.2UF K	
C73			CK73GB1C104K	CHIP C 0.10UF K	K2M2E2
C73			CK73GB1C104K	CHIP C 0.10UF K	E
C85			CK73FB1A225K	CHIP C 2.2UF K	
C192			CK73GB1H681K	CHIP C 680PF K	
C200-206			CK73GB1C104K	CHIP C 0.10UF K	
C300			C92-0712-05	CHIP-TAN 22UF 6.3WV	
C301			CK73GB1C104K	CHIP C 0.10UF K	
CN1			E40-9338-05	FLAT CABLE CONNECTOR (23P)	
CN2			E40-9404-05	FLAT CABLE CONNECTOR (16P)	
L2			L92-0322-05	CHIP FERRITE	
X1			L78-0596-05	RESONATOR (16.93MHz)	
X2			L78-0568-05	RESONATOR (12.5MHz)	
CP1			R90-0720-05	MULTI-COMP 100K X4	
CP3			R90-0720-05	MULTI-COMP 100K X4	
CP5,6			R90-1014-05	MULTI-COMP 100 X4	
CP7,8			R90-0720-05	MULTI-COMP 100K X4	
CP9			R90-0725-05	MULTI-COMP 1K X2	
CP10-12			R90-1014-05	MULTI-COMP 100 X4	K2M2E2
CP10-12			R90-1014-05	MULTI-COMP 100 X4	E
CP12			R90-1014-05	MULTI-COMP 100 X4	K3M3
CP14,15			R90-0720-05	MULTI-COMP 100K X4	
CP16			R90-0724-05	MULTI-COMP 1K X4	
CP17			R90-0720-05	MULTI-COMP 100K X4	

Ref. No.	Ad	New	Parts No.	Description	Destination
R4			RK73GB1J391J	CHIP R 390	J 1/16W
R5			RK73GB1J302J	CHIP R 3.0K	J 1/16W
R7			RK73GB1J302J	CHIP R 3.0K	J 1/16W
R8			RK73EB2B100J	CHIP R 10	J 1/8W
R9			RK73GB1J102J	CHIP R 1.0K	J 1/16W
R10			RK73GB1J104J	CHIP R 100K	J 1/16W
R11-14			RK73GB1J103J	CHIP R 10K	J 1/16W
R15			RK73GB1J104J	CHIP R 100K	J 1/16W
R16			RK73GB1J562J	CHIP R 5.6K	J 1/16W
R17			RK73EB2B103J	CHIP R 10K	J 1/8W
R18			RK73GB1J103J	CHIP R 10K	J 1/16W
R19			RK73GB1J333J	CHIP R 33K	J 1/16W
R20			RK73GB1J104J	CHIP R 100K	J 1/16W
R21			RK73GB1J123J	CHIP R 12K	J 1/16W
R22			RK73GB1J183J	CHIP R 18K	J 1/16W
R25			RK73GB1J113J	CHIP R 11K	J 1/16W
R26			RK73EB2B123J	CHIP R 12K	J 1/8W
R53,54			RK73GB1J681J	CHIP R 680	J 1/16W
R57,58			RK73GB1J223J	CHIP R 22K	J 1/16W
R59			RK73GB1J914J	CHIP R 910K	J 1/16W
R60,61			RK73EB2B101J	CHIP R 100	J 1/8W
R67			RK73GB1J124J	CHIP R 120K	J 1/16W
R68			RK73EB2B124J	CHIP R 120K	J 1/8W
R69,70			RK73GB1J303J	CHIP R 30K	J 1/16W
R71			RK73GB1J912J	CHIP R 9.1K	J 1/16W
R72,73			RK73GB1J101J	CHIP R 100	J 1/16W
R74,75			RK73GB1J223J	CHIP R 22K	J 1/16W
R76			RK73GB1J104J	CHIP R 100K	J 1/16W
R77			RK73GB1J183J	CHIP R 18K	J 1/16W
R78			RK73GB1J104J	CHIP R 100K	J 1/16W
R79			RK73GB1J332J	CHIP R 3.3K	J 1/16W
R80			RK73GB1J102J	CHIP R 1.0K	J 1/16W
R81			RK73GB1J103J	CHIP R 10K	J 1/16W
R82-84			RK73GB1J102J	CHIP R 1.0K	J 1/16W
R85-87			RK73GB1J104J	CHIP R 100K	J 1/16W
R93			RK73GB1J224J	CHIP R 220K	J 1/16W
R95,96			RK73GB1J104J	CHIP R 100K	J 1/16W
R97,98			RK73GB1J103J	CHIP R 10K	J 1/16W
R99			RK73GB1J104J	CHIP R 100K	J 1/16W
R100,101			RK73GB1J102J	CHIP R 1.0K	J 1/16W
R102			RK73GB1J104J	CHIP R 100K	J 1/16W
R105,106			RK73GB1J102J	CHIP R 1.0K	J 1/16W
R107			RK73GB1J101J	CHIP R 100	J 1/16W
R108			RK73GB1J104J	CHIP R 100K	J 1/16W
R110,111			RK73GB1J104J	CHIP R 100K	J 1/16W
R112			RK73GB1J103J	CHIP R 10K	J 1/16W
R120			RK73GB1J393J	CHIP R 39K	J 1/16W
R121			RK73GB1J103J	CHIP R 10K	J 1/16W
R122,123			RK73GB1J102J	CHIP R 1.0K	J 1/16W
R124			RK73GB1J223J	CHIP R 22K	J 1/16W
R127			RK73GB1J104J	CHIP R 100K	J 1/16W
R129			RK73GB1J102J	CHIP R 1.0K	J 1/16W
R133,134			RK73GB1J104J	CHIP R 100K	J 1/16W
R135-138			RK73GB1J101J	CHIP R 100	J 1/16W
R139-143			RK73GB1J104J	CHIP R 100K	J 1/16W

# KDC-C517FM, C717/Y

## PARTS LIST

\* New Parts

Parts without **Parts No.** are not supplied.

Les articles non mentionnes dans le **Parts No.** ne sont pas fournis.

Teile ohne **Parts No.** werden nicht geliefert.

### CD PLAYER UNIT (X32-5090-0X)

Ref. No.	A d d	N e w	Parts No.	Description	Dest inati on
R148,149			RK73GB1J101J	CHIP R 100 J 1/16W	
R150			RK73GB1J102J	CHIP R 1.0K J 1/16W	
R151			RK73GB1J471J	CHIP R 470 J 1/16W	
R152			RK73GB1J913J	CHIP R 91K J 1/16W	
R153,154			RK73GB1J472J	CHIP R 4.7K J 1/16W	
R155,156			RK73GB1J101J	CHIP R 100 J 1/16W	
R157			RK73GB1J102J	CHIP R 1.0K J 1/16W	K3M3
R161			RK73GB1J163J	CHIP R 16K J 1/16W	
R162			RK73GB1J472J	CHIP R 4.7K J 1/16W	
R190,191			RK73GB1J223J	CHIP R 22K J 1/16W	
R191			RK73GB1J123J	CHIP R 12K J 1/16W	
R205			RK73EB2B102J	CHIP R 1.0K J 1/8W	
R206			RK73GB1J102J	CHIP R 1.0K J 1/16W	
W2			R92-1252-05	CHIP R 0 OHM	
W3			R92-2053-05	CHIP R 0 J 1/8W	
W5 -7			R92-1252-05	CHIP R 0 OHM	
S1			S68-0823-05	PUSH SWITCH	
S2			S70-0838-05	TACT SWITCH	
S3			S68-0823-05	PUSH SWITCH	
S4			S62-0863-05	SLIDE SWITCH	
D1			DAP202K	DIODE	
D3 ,4			MA3056-M	ZENER DIODE	
D5			MA8075-M	ZENER DIODE	
D7			MA3056-M	ZENER DIODE	
D8			MA8062-M	ZENER DIODE	
D9 ,10			M1F60	DIODE	
D11			1SR154-400	DIODE	
D12			DA204U	DIODE	
D14			MA8091-M	ZENER DIODE	
D15			DAP202K	DIODE	
D16			DAP202U	DIODE	
D21 ,22			DAN202K	DIODE	
D23 ,24			DAN202U	DIODE	
IC1		*	UPD63711AGC	MOS-IC	
IC4			KIA78L05F	IC(VOLTAGE REGULATOR/ +5V)	
IC5		*	LA6576	ANALOGUE IC	
IC7		*	UPD784214GC091	MI-COM IC	
IC8			BR24C02F-W	MEMORY IC	
IC8		*	CAT24WC02JI	MEMORY IC	
IC8		*	M24C02WMMN6T	MEMORY IC	
IC8		*	S-24C02BFJA	MEMORY IC	
IC8		*	24LC02BT-ISN	MEMORY IC	
IC9			S-80830ANNP	MOS-IC	
IC11			LC3564BT-70	MEMORY IC	K2M2E2
IC11			LC3564BT-70	MEMORY IC	E
Q1			MCH6101	TRANSISTOR	
Q4			DTA124EK	DIGITAL TRANSISTOR	
Q5			DTA124EUA	DIGITAL TRANSISTOR	
Q6 ,7			DTC343TK	DIGITAL TRANSISTOR	
Q8			DTA124EK	DIGITAL TRANSISTOR	
Q9			2SB1202	TRANSISTOR	
Q10			2SB1295	TRANSISTOR	
Q11			DTC124EK	DIGITAL TRANSISTOR	
Q13			DTC124EUA	DIGITAL TRANSISTOR	

Ref. No.	A d d	N e w	Parts No.	Description	Dest inati on
Q14			DTA143EUA	DIGITAL TRANSISTOR	
Q16			2SC4081	TRANSISTOR	
Q17			DTA143EK	DIGITAL TRANSISTOR	
Q18 ,19			DTC124EUA	DIGITAL TRANSISTOR	
Q20			DTC124EK	DIGITAL TRANSISTOR	
Q21			2SB1202	TRANSISTOR	
Q22			2SC4081	TRANSISTOR	
Q30			DTC114YUA	DIGITAL TRANSISTOR	
Q31			DTC124EUA	DIGITAL TRANSISTOR	
TH1			NTH5G20B333K07	THERMISTOR	
<b>MECHANISM ASSY (X92-4310-0X)</b>					
1	2B	*	A10-4745-03	CHASSIS ASSY	
2	2B	*	A10-4748-02	CHASSIS CALKING ASSY	
3	2B	*	A10-4751-03	CHASSIS CALKING ASSY	
4	3A	*	A10-4754-04	CHASSIS CALKING ASSY	
5	2A	*	A10-4757-02	CHASSIS CALKING ASSY	
6	2A	*	A10-4759-02	CHASSIS	
7	1A	*	A10-4760-02	CHASSIS CALKING ASSY	
C75	3A		C90-2945-05	ELECTRO 0.047F 5.5WV	K2M2E2
C75	3A		C90-2945-05	ELECTRO 0.047F 5.5WV	E
11	2B		D10-4293-03	ARM	
12	2A	*	D10-4527-03	SLIDER	
13	2B	*	D10-4528-03	ARM	
14	2B	*	D10-4529-03	LEVER	
15	3A	*	D10-4531-04	LEVER ASSY	
16	2A	*	D10-4533-03	LEVER	
17	2A	*	D10-4534-04	SLIDER ASSY	
18	1B	*	D10-4536-13	SLIDER	
19	3A	*	D10-4537-04	SLIDER ASSY	
20	1B	*	D10-4540-13	ARM	
21	1B	*	D10-4547-03	LEVER	
22	2B	*	D12-0630-02	CAM	
23	2B	*	D12-0631-02	CAM	
24	3B	*	D13-2185-04	GEAR	
25	3B	*	D13-2186-04	GEAR	
26	3B	*	D13-2187-04	GEAR	
27	3A	*	D13-2188-04	WORM	
28	2B	*	D13-2092-04	GEAR	
29	2B	*	D13-2093-04	GEAR ASSY	
30	2B	*	D13-2095-04	GEAR	
31	2B	*	D13-2096-04	GEAR	
32	3A	*	D13-2099-04	GEAR	
33	3A	*	D13-2100-04	GEAR	
34	3A	*	D13-2101-04	GEAR	
35	3A	*	D13-2102-04	GEAR	
36	3A	*	D13-2103-04	GEAR	
37	3A	*	D13-2104-04	GEAR	
38	3B	*	D19-0636-04	LEAD SCREW	
39	3A	*	D19-0637-04	CLUTCH ASSY	
40	3A		D39-0225-05	DAMPER	
FC1	3A		E39-0172-15	FLAT CABLE (23P)	
FC2	3A		E39-0173-15	FLAT CABLE (16P)	
45	3B	*	F09-1645-04	SHEET	

# KDC-C517FM, C717/Y

## PARTS LIST

\*New Parts

Parts without **Parts No.** are not supplied.

Les articles non mentionnes dans le **Parts No.** ne sont pas fournis.

Teile ohne **Parts No.** werden nicht geliefert.

### MECHANISM ASSY (X92-4310-0X)

Ref. No.	A d d	N e w	Parts No.	Description	Dest inati on
46	2B	*	G01-3036-04	TORSION COIL SPRING	
47	1B	*	G01-3037-04	EXTENSION SPRING	
48	2B	*	G01-3038-04	TORSION COIL SPRING	
49	3A	*	G01-3039-04	COMPRESSION SPRING	
50	3A	*	G01-3040-04	EXTENSION SPRING	
51	3A	*	G01-3041-04	EXTENSION SPRING	
52	1B	*	G01-3042-04	TORSION COIL SPRING	
53	2A	*	G01-3043-04	TORSION COIL SPRING	
54	1B	*	G01-3044-04	EXTENSION SPRING	
55	2A	*	G01-3045-04	EXTENSION SPRING (BLACK)	
56	2A	*	G01-3046-04	EXTENSION SPRING (SILVER)	
57	3B	*	G02-1374-04	FLAT SPRING	
58	3B	*	G02-1375-03	FLAT SPRING	
59	2B	*	G02-1376-03	FLAT SPRING	
61	2B	*	G02-1378-04	FLAT SPRING	
62	3A	*	G02-1380-04	FLAT SPRING	
63	2A	*	G10-1045-14	FELT	
68	2B	*	J11-0637-03	CLAMPER	
69	3B	*	J21-9592-04	MOUNTING HARDWARE	
70	1B	*	J21-9595-03	MOUNTING HARDWARE	
73	2B	*	J90-0759-03	GUIDE	
74	2A	*	J90-0760-03	RAIL	
75	2B	*	J90-0777-23	GUIDE	
FPC1	3B	*	J84-0099-05	FLEXIBLE PRINTED WIRING BOARD	
A	2A		N09-4126-05	MACHINE SCREW (2X3.5,C,BLK)	
B	3A		N09-4288-05	TAPTITE SCREW (2X2.5,S)	
C	3A		N86-2005-46	BINDING HEAD TAPTITE SCREW	
D	2B		N09-4189-05	TAPTITE SCREW (1.7X1.5,S)	
E	3B		N09-4154-05	TAPTITE SCREW (2X6,P)	
F	2B		N09-4181-05	MACHINE SCREW (M1.7X3,LOCK)	
G	3B		N39-1722-46	PAN HEAD MACHIN SCREW	
H	1A		N09-4349-05	TAPTITE SCREW (2X3.5,S)	
J	3A		N19-2105-14	FLAT WASHER (1.55X3.8X0.35)	
K	3A		N19-2058-04	FLAT WASHER (1.6X4X0.25)	
L	1B		N19-2080-14	FLAT WASHER (1.55X3.8X0.3)	
M	2B		N19-2028-04	FLAT WASHER (1.6X3.5X0.25)	
76	3A	*	R33-0207-05	SLIDE TYPE VAR. R (10k B)	
M1	3B		T42-0797-04	MOTOR ASSY	
M2 ,3	3A		T42-0788-05	DC MOTOR	
PU1	3B	*	T25-0105-05	OPTICAL PICKUP HEAD	
Q15	3A		2SB1565(E,F)	TRANSISTOR	
RF MODULATOR					
302	1F		A01-2723-08	CASE	K3M3
303	1E		B07-2138-08	HOLDER ASSY	K3M3
AT1	1E		E30-4310-08	ANTENNA CORD ASSY	K3M3
DC1	1E		E30-4733-08	DC CORD	K3M3
F1 ,2	2E		F06-3026-05	FUSE (3A)	K3M3
V	1F		N09-4207-08	SCREW (3X6,Ni-B)	K3M3
W	3F		N09-4206-08	SCREW (for CN102 x2)(3X8)	K3M3

Ref. No.	A d d	N e w	Parts No.	Description	Dest inati on
305	3E		T95-0247-08	DISPLAY UNIT ASSY	K3M3
306	1E		W01-0763-08	MAGICTAPE ASSY	K3M3
RF MODULATOR UNIT					
C1			C90-2583-05	ELECTRO 1000UF 16WV	K3M3
C2			CK73FB1H223K	CHIP C 0.022UF K	K3M3
C3			CE04NW1H4R7M	ELECTRO 4.7UF 50WV	K3M3
C6			CE04NW1C100M	ELECTRO 10UF 16WV	K3M3
C7			CE04NW1H010M	ELECTRO 1.0UF 50WV	K3M3
C8			CK73FB1H102K	CHIP C 1000PF K	K3M3
C9 ,10			CK73FB1H103K	CHIP C 0.010UF K	K3M3
C11 ,12			CC73FCH1H220J	CHIP C 22PF J	K3M3
C13 -17			CK73FB1H102K	CHIP C 1000PF K	K3M3
C19			CE04DW1A101M	ELECTRO 100UF 10WV	K3M3
C20			CE04DW1E221M	ELECTRO 220UF 25WV	K3M3
C24			CE04DW1C471M	ELECTRO 470UF 16WV	K3M3
C30			CE04DW1A102M	ELECTRO 1000UF 10WV	K3M3
C31			CE04DW1A221M	ELECTRO 220UF 10WV	K3M3
C32			CE04DW1A101M	ELECTRO 100UF 10WV	K3M3
C33			C90-2583-05	ELECTRO 1000UF 16WV	K3M3
C34			CE04NW1H010M	ELECTRO 1.0UF 50WV	K3M3
C35			CK73FB1H103K	CHIP C 0.010UF K	K3M3
C36			C90-2689-05	ELECTRO 3300UF 16WV	K3M3
C103			CK73FB1H103K	CHIP C 0.010UF K	K3M3
C104			CE04NW1C100M	ELECTRO 10UF 16WV	K3M3
C105			CE04DW1A221M	ELECTRO 220UF 10WV	K3M3
C106			CE04NW1C100M	ELECTRO 10UF 16WV	K3M3
C107			CC73FCH1H271J	CHIP C 270PF J	K3M3
C108			CK73FB1H102K	CHIP C 1000PF K	K3M3
C109,110			CK73FF1H104Z	CHIP C 0.10UF Z	K3M3
C111			CE04NW1H010M	ELECTRO 1.0UF 50WV	K3M3
C112			CK73FB1H332K	CHIP C 3300PF K	K3M3
C113			CC73FCH1H181J	CHIP C 180PF J	K3M3
C114			CK73FB1H153K	CHIP C 0.015UF K	K3M3
C203			CK73FB1H103K	CHIP C 0.010UF K	K3M3
C204			CE04NW1C100M	ELECTRO 10UF 16WV	K3M3
C205			CE04DW1A221M	ELECTRO 220UF 10WV	K3M3
C206			CE04NW1C100M	ELECTRO 10UF 16WV	K3M3
C207			CC73FCH1H271J	CHIP C 270PF J	K3M3
C208			CK73FB1H102K	CHIP C 1000PF K	K3M3
C209,210			CK73FF1H104Z	CHIP C 0.10UF Z	K3M3
C211			CE04NW1H010M	ELECTRO 1.0UF 50WV	K3M3
C212			CK73FB1H332K	CHIP C 3300PF K	K3M3
C213			CC73FCH1H181J	CHIP C 180PF J	K3M3
C214			CK73FB1H153K	CHIP C 0.015UF K	K3M3
C301			CE04NW1C100M	ELECTRO 10UF 16WV	K3M3
C302			CK73FB1H103K	CHIP C 0.010UF K	K3M3
C303			CC73FCH1H221J	CHIP C 220PF J	K3M3
C304			CC73FCH1H100D	CHIP C 10PF D	K3M3
C305			CK73FB1H103K	CHIP C 0.010UF K	K3M3
C306			CC73FCH1H221J	CHIP C 220PF J	K3M3
C308			CK73FB1H333K	CHIP C 0.033UF K	K3M3
C310			CC73FCH1H330J	CHIP C 33PF J	K3M3
C312			CK73FB1H103K	CHIP C 0.010UF K	K3M3



# KDC-C517FM, C717/Y

## PARTS LIST

\* New Parts

Parts without **Parts No.** are not supplied.

Les articles non mentionnes dans le **Parts No.** ne sont pas fournis.

Teile ohne **Parts No.** werden nicht geliefert.

### RF MODULATOR UNIT

Ref. No.	A d	N e w	Parts No.	Description	Dest ination
C314			CE04NW1HR22M	ELECTRO 0.22UF 50WV	K3M3
C315			CE04DW1A101M	ELECTRO 100UF 10WV	K3M3
C316			CK73FB1H103K	CHIP C 0.010UF K	K3M3
C317			CE04NW1H2R2M	ELECTRO 2.2UF 50WV	K3M3
C318,319			CK73FB1H103K	CHIP C 0.010UF K	K3M3
C320			CC73FCH1H181J	CHIP C 180PF J	K3M3
C321			CE04NW1H010M	ELECTRO 1.0UF 50WV	K3M3
C322			CC73FUJ1H221J	CHIP C 220PF J	K3M3
C323			CC73FUJ1H680J	CHIP C 68PF J	K3M3
C324			CC73FUJ1H150J	CHIP C 15PF J	K3M3
C325			CK73FB1H103K	CHIP C 0.010UF K	K3M3
C326			CE04DW1E470M	ELECTRO 47UF 25WV	K3M3
C327			CC73FUJ1H150J	CHIP C 15PF J	K3M3
C328			CC73FCH1H020C	CHIP C 2.0PF C	K3M3
C329			CC73FCH1H150J	CHIP C 15PF J	K3M3
C330			CK73FB1H103K	CHIP C 0.010UF K	K3M3
C331			CC73FCH1H010C	CHIP C 1.0PF C	K3M3
C332			CC73FCH1H050C	CHIP C 5.0PF C	K3M3
C333,334			CC73FCH1H330J	CHIP C 33PF J	K3M3
C335			CE04NW1H4R7M	ELECTRO 4.7UF 50WV	K3M3
C336			CK73FB1H222K	CHIP C 2200PF K	K3M3
C338			CC73FCH1H050C	CHIP C 5.0PF C	K3M3
VC301			C05-0513-08	TRIMMER C (20PF)	K3M3
CN101		*	E56-0811-05	CONNECTOR (8P)	K3M3
CN102			E56-0833-08	CONNECTOR (13P)	K3M3
CN104,105			E40-3237-05	PIN ASSY	K3M3
L1			L33-0934-08	CHOKING COIL	K3M3
L301			L33-1043-08	SMALL FIXED INDUCTOR (0.22uH)	K3M3
L302,303			L33-0976-08	SMALL FIXED INDUCTOR (2.2uH)	K3M3
L304			L33-1043-08	SMALL FIXED INDUCTOR (0.22uH)	K3M3
L305			L33-1042-08	SMALL FIXED INDUCTOR (0.12uH)	K3M3
X301			L77-2716-08	CRYSTAL RESONATOR (38KHz)	K3M3
X302			L77-2062-08	CRYSTAL RESONATOR (4.5MHz)	K3M3
R1			RD14BB2C242J	RD 2.4K J 1/6W	K3M3
R2			RD14BB2C222J	RD 2.2K J 1/6W	K3M3
R6			RK73FB2A223J	CHIP R 22K J 1/10W	K3M3
R7			R92-2148-08	CHIP R 22 J 2W	K3M3
R8			RD14BB2C223J	RD 22K J 1/6W	K3M3
R9			RD14BB2C222J	RD 2.2K J 1/6W	K3M3
R11			RD14BB2C102J	RD 1.0K J 1/6W	K3M3
R12			RD14BB2C103J	RD 10K J 1/6W	K3M3
R13			RD14BB2C104J	RD 100K J 1/6W	K3M3
R14			RD14BB2C332J	RD 3.3K J 1/6W	K3M3
R15			RD14BB2C104J	RD 100K J 1/6W	K3M3
R16			RD14BB2C332J	RD 3.3K J 1/6W	K3M3
R17			RD14BB2C102J	RD 1K J 1/6W	K3M3
R18			RK73FB2A104J	CHIP R 100K J 1/10W	K3M3
R19			RD14BB2C332J	RD 3.3K J 1/6W	K3M3
R20			RD14BB2C102J	RD 1K J 1/6W	K3M3
R21			RD14BB2C472J	RD 4.7K J 1/6W	K3M3
R22,23			RD14BB2C102J	RD 1.0K J 1/6W	K3M3
R24			RD14BB2C472J	RD 4.7K J 1/6W	K3M3
R25,26			RD14BB2C102J	RD 1.0K J 1/6W	K3M3

Ref. No.	A d	N e w	Parts No.	Description	Dest ination
R27,28			RK73FB2A103J	CHIP R 10K J 1/10W	K3M3
R31			RK73FB2A473J	CHIP R 47K J 1/10W	K3M3
R33			RK73FB2A473J	CHIP R 47K J 1/10W	K3M3
R34			RK73FB2A182J	CHIP R 1.8K J 1/10W	K3M3
R35			RK73FB2A151J	CHIP R 150 J 1/10W	K3M3
R102			RK73FB2A152J	CHIP R 1.5K J 1/10W	K3M3
R103			RK73FB2A682J	CHIP R 6.8K J 1/10W	K3M3
R104			RK73FB2A103J	CHIP R 10K J 1/10W	K3M3
R105-108			R92-0363-05	CHIP R 10K F 1/10W	K3M3
R109			RK73FB2A182J	CHIP R 1.8K J 1/10W	K3M3
R110			RK73FB2A391J	CHIP R 390 J 1/10W	K3M3
R111			RK73FB2A102J	CHIP R 1.0K J 1/10W	K3M3
R112			RK73FB2A753J	CHIP R 75K J 1/10W	K3M3
R113			RK73FB2A104J	CHIP R 100K J 1/10W	K3M3
R114-116			RK73FB2A682J	CHIP R 6.8K J 1/10W	K3M3
R202			RK73FB2A152J	CHIP R 1.5K J 1/10W	K3M3
R203			RK73FB2A682J	CHIP R 6.8K J 1/10W	K3M3
R204			RK73FB2A103J	CHIP R 10K J 1/10W	K3M3
R205-208			R92-0363-05	CHIP R 10K D 1/10W	K3M3
R209			RK73FB2A182J	CHIP R 1.0K J 1/10W	K3M3
R210			RK73FB2A391J	CHIP R 390 J 1/10W	K3M3
R212			RK73FB2A753J	CHIP R 75K J 1/10W	K3M3
R213			RK73FB2A104J	CHIP R 100K J 1/10W	K3M3
R214-216			RK73FB2A682J	CHIP R 6.8K J 1/10W	K3M3
R301			RK73FB2A154J	CHIP R 150K J 1/10W	K3M3
R302			RK73FB2A123J	CHIP R 12K J 1/10W	K3M3
R306			RK73FB2A103J	CHIP R 10K J 1/10W	K3M3
R307			RK73FB2A472J	CHIP R 4.7K J 1/10W	K3M3
R308			RK73FB2A154J	CHIP R 150K J 1/10W	K3M3
R314			RK73FB2A473J	CHIP R 47K J 1/10W	K3M3
R316			RK73FB2A122J	CHIP R 1.2K J 1/10W	K3M3
R317			RK73FB2A242J	CHIP R 2.4K J 1/10W	K3M3
R318			RK73FB2A332J	CHIP R 2.7K J 1/10W	K3M3
R319			RD14BB2C122J	RD 1.2K J 1/6W	K3M3
R320			RK73FB2A103J	CHIP R 10K J 1/10W	K3M3
R322			RD14BB2C472J	RD 4.7K J 1/6W	K3M3
R323			RK73FB2A471J	CHIP R 470 J 1/10W	K3M3
R325,326			RK73FB2A223J	CHIP R 22K J 1/10W	K3M3
R327			RK73FB2A473J	CHIP R 47K J 1/10W	K3M3
R328			RK73FB2A271J	CHIP R 270 J 1/10W	K3M3
R329			RK73FB2A470J	CHIP R 47 J 1/10W	K3M3
R330			RK73FB2A331J	CHIP R 330 J 1/10W	K3M3
R331			RK73FB2A473J	CHIP R 47K J 1/10W	K3M3
R332			RK73FB2A101J	CHIP R 100 J 1/10W	K3M3
R333			RK73FB2A470J	CHIP R 47 J 1/10W	K3M3
R334			RK73FB2A472J	CHIP R 4.7K J 1/10W	K3M3
R337,338			RK73FB2A472J	CHIP R 4.7K J 1/10W	K3M3
R339,340			RK73FB2A391J	CHIP R 390 J 1/10W	K3M3
R343			RK73FB2A101J	CHIP R 100 J 1/10W	K3M3
R346			RK73FB2A472J	CHIP R 4.7K J 1/10W	K3M3
R348			RK73FB2A224J	CHIP R 220K J 1/10W	K3M3
VR301			R32-0208-08	TRIMMING POT. 33K(B)	K3M3
VR303			R32-0207-08	TRIMMING POT. 10K(B)	K3M3
RL1			S76-0802-08	MAGNET RELAY	K3M3

# KDC-C517FM, C717/Y

## PARTS LIST

\*New Parts

Parts without **Parts No.** are not supplied.

Les articles non mentionnes dans le **Parts No.** ne sont pas fournis.

Teile ohne **Parts No.** werden nicht geliefert.

### RF MODULATOR UNIT

Ref. No.	Added	New	Parts No.	Description	Destination
D1			DSK10C-ET1	DIODE	K3M3
D2			DSK10C-BT	DIODE	K3M3
D5			DSK10C-ET1	DIODE	K3M3
D8 ,9			1SS131	DIODE	K3M3
D12 ,13			1SS131	DIODE	K3M3
D14			DSK10C-ET1	DIODE	K3M3
D15			DSK10C-BT	DIODE	K3M3
D16			1SS131	DIODE	K3M3
D101			DA204K	DIODE	K3M3
D201			DA204K	DIODE	K3M3
D302			DA204K	DIODE	K3M3
IC1			UPC7805AHF	IC(VOLTAGE REGULATOR/ +5V)	K3M3
IC2			LC72329-9274	IC (MICRO COMPUTER)	K3M3
IC4			NJM78L05UA	IC(VOLTAGE REGULATOR/ +5V)	K3M3
IC101			NJM2060M	IC(OP AMP X4)	K3M3
IC102			NJM4565MD	IC(OP AMP X2)	K3M3
IC301			BA1405F	IC (MPX)	K3M3
IC302			NJM4565MD	IC(OP AMP X2)	K3M3
Q1			DTC124EK	DIGITAL TRANSISTOR	K3M3
Q2			2SA1782(T,U)	TRANSISTOR	K3M3
Q3			DTC124EK	DIGITAL TRANSISTOR	K3M3
Q4 ,5			DTC143TK	DIGITAL TRANSISTOR	K3M3
Q6			DTA124EK	DIGITAL TRANSISTOR	K3M3
Q8			DTC143TK	DIGITAL TRANSISTOR	K3M3
Q9			2SC4640(T,U)	TRANSISTOR	K3M3
Q101			2SK2158	FET	K3M3
Q201			2SK2158	FET	K3M3
Q303			2SA1162(GR)	TRANSISTOR	K3M3
Q304,305			2SK2158	FET	K3M3
Q306			2SK508L	FET	K3M3
Q307			2SC2714(Y)	TRANSISTOR	K3M3
Q308-310			2SK2158	FET	K3M3
VD301			HVU306A-3	VARIABLE DIODE	K3M3
ZD1 -7			MTZ6.2J(B)	ZENER DIODE	K3M3

Ref. No.	Added	New	Parts No.	Description	Destination
R4			RK73GB1J101J	CHIP R 100 J 1/16W	K3M3
R5			RK73GB1J222J	CHIP R 2.2K J 1/16W	K3M3
R6			RK73GB1J513J	CHIP R 51K J 1/16W	K3M3
R7 -15			RK73FB2A470J	CHIP R 47 J 1/10W	K3M3
R16 ,17			RK73GB1J102J	CHIP R 1.0K J 1/16W	K3M3
SW1 -9			S70-0828-08	TACT SWITCH	K3M3
D1 -5			DA204K	DIODE	K3M3
IC1			LC75852W	IC (LCD DRIVER)	K3M3
IC2			PNA4602M	IC (REMOTE SENSOR)	K3M3
Q1			DTC144EK	DIGITAL TRANSISTOR	K3M3
Q2			DTB123YK	DIGITAL TRANSISTOR	K3M3
Q3			DTA144EK	DIGITAL TRANSISTOR	K3M3
Q4			DTC144EK	DIGITAL TRANSISTOR	K3M3
Q5			DTA144EK	DIGITAL TRANSISTOR	K3M3

### DISPLAY UNIT

320	2E		A02-1460-08	FRONT CASE	K3M3
321	3E		A02-1446-08	REAR CASE	K3M3
323	2E		B10-3055-08	FRONT GLASS ASSY	K3M3
LCD1	3E		B38-0643-08	LCD	K3M3
LED1-18			B30-1459-08	LED	K3M3
C1			C92-0047-05	CHIP-ELE 47UF 6.3WV	K3M3
C2			CK73GB1H681K	CHIP C 680PF K	K3M3
C3			C92-0037-05	CHIP-ELE 10UF 16WV	K3M3
C4 ,5			CK73FB1H223K	CHIP C 0.022UF K	K3M3
CN1	3E		E30-4309-08	DIN CORD ASSY (8P)	K3M3
331	3E		K25-0713-08	KNOB (REP, RDM, PLAY/PAUSE)	K3M3
332	2E		K29-5576-08	KNOB ASSY (PWR, RESET)	K3M3
333	2E		K29-5585-08	KNOB (TRACK)	K3M3
334	3E		K29-5586-08	KNOB (DISC)	K3M3
Y	3E		N79-2040-45	SCREW (POWER-KEY x1)	K3M3
Z	3E		N79-2080-45	SCREW (REAR CASE x1)	K3M3
R1 -3			RK73GB1J222J	CHIP R 2.2K J 1/16W	K3M3

**MEMO**

# KDC-C517FM, C717/Y

## SPECIFICATIONS

### KDC-C517FM

#### Disc section

Laser Diode .....	GaAlAs ( $\lambda=780\text{nm}$ )
Digital Filter .....	8 Times Over Sampling
D/A Converter .....	1Bit
Spindle Speed .....	500rpm~200rpm (CLV)
Wow & Flutter .....	Below Measurable Limit
Frequency Response.....	10Hz~20kHz ( $\pm 1\text{dB}$ )
Modulating Frequency .....	87.7MHz~89.9MHz (200kHz step)

#### General

Operating Voltage .....	14.4V (11V~16V)
Current Consumption .....	1.4A
Operating Temperature .....	-10~50°C

#### Installation size

CD Changer .....	250(W) $\times$ 80(H) $\times$ 176(D)mm 9-13/16(W) $\times$ 3-1/8(H) $\times$ 6-13/16(D)inch
Remote controller Unit .....	50(W) $\times$ 145(H) $\times$ 24(D)mm 1-15/16(W) $\times$ 5-3/4(H) $\times$ 1(D)inch
Display Unit .....	105(W) $\times$ 40(H) $\times$ 18(D)mm 4-1/8(W) $\times$ 1-9/16(H) $\times$ 11/16(D)inch
Hide-away Unit .....	150(W) $\times$ 30(H) $\times$ 80(D)mm 5-7/8(W) $\times$ 1-3/16(H) $\times$ 3-1/8(D)inch

#### Weight

CD Changer .....	2.0kg (4.4lbs)
Remote controller Unit .....	0.06kg (0.14lbs)
Display Unit .....	0.125kg (0.28lbs)
Hide-away Unit .....	0.6kg (1.3lbs)

### KDC-C717/Y

#### Disc section

Laser Diode .....	GaAlAs ( $\lambda=780\text{nm}$ )
Digital Filter .....	8 Times Over Sampling
D/A Converter .....	1Bit
Spindle Speed .....	500rpm~200rpm (CLV)
Wow & Flutter .....	Below Measurable Limit
Frequency Response.....	5Hz~20kHz ( $\pm 1\text{dB}$ )
Total Harmonic Distortion .....	0.005% (1kHz)
S/N Ratio .....	100dB
Dynamic Range .....	94dB
Channel Separation .....	96dB

#### General

Operating Voltage .....	14.4V (11V~16V)
Current Consumption .....	0.8A
Installation size .....	250(W) $\times$ 80(H) $\times$ 176(D)mm 9-13/16(W) $\times$ 3-1/8(H) $\times$ 6-13/16(D)inch
Weight .....	2.0kg(4.4lbs)

---

**KENWOOD** follows a policy of continuous advancements in development. For this reason specifications may be changed without notice.

---

## KENWOOD CORPORATION

14-6, Dogenzaka 1-chome, Shibuya-ku, Tokyo 150-8501 Japan

**KENWOOD SERVICE CORPORATION**  
P.O. BOX 22745, 2201 East Dominguez Street, Long Beach, CA90801-5745, U.S.A.

**KENWOOD ELECTRONICS CANADA INC.**  
6070 Kestrel Road, Mississauga, Ontario, Canada L5T 1S8

**KENWOOD ELECTRONICS LATIN AMERICA S.A.**  
P.O. Box 55-2791 Paitilla, Plaza Credicorp Bank Panama,  
Piso 9, Oficina 901, Calle 50, Panama, Rep. de Panama

**KENWOOD ELECTRONICS BRASIL LTDA.**  
Av. Moema, 170-17, Andar-Cobertura "B", Ed. Maximum Service Center, 04077-020  
Moema, São Paulo-SP-Brasil

**KENWOOD ELECTRONICS UK LIMITED**  
Kenwood House, Dwight Road, Watford, Herts, WD1 8EB, United Kingdom

**KENWOOD ELECTRONICS DEUTSCHLAND GMBH**  
Rembrücker-Str. 15, 63150 Heusenstamm, Germany

**KENWOOD ELECTRONICS FRANCE S.A.**  
13, Boulevard Ney, 75018 Paris, France

**KENWOOD ELECTRONICS BELGIUM N.V.**  
Mechelsteeweg 418, B-1930 Zaventem, Belgium

**KENWOOD ELECTRONICS ITALIA S.p.A.**  
Via G. Sirtori 7/9, 20129 Milano, Italy

**KENWOOD IBÉRICA S.A.**  
Bolivia, 239-08020 Barcelona, Spain

**KENWOOD ELECTRONICS AUSTRALIA PTY. LTD. (A.C.N. 001 499 074)**  
16 Giffnock Avenue, Centrecourt Estate, North Ryde,  
N.S.W. 2113, Australia

**KENWOOD ELECTRONICS (HONG KONG) LTD.**  
Unit 3712-3724, Level 37, Tower 1, Metroplaza, 223 Hing Fong Road, Kwai Fong, N.T.,  
Hong Kong

**KENWOOD ELECTRONICS GULF FZE**  
P.O. Box 61318, Jebel Ali, Dubai, U.A.E.

**KENWOOD ELECTRONICS (THAILAND) CO., LTD.**  
2019 New Pechburi Road, Bangkok, Huaykwang, Bangkok, 10320 Thailand

**KENWOOD ELECTRONICS SINGAPORE PTE. LTD.**  
1 Genting Lane, #07-00, Kenwood Building, Singapore, 349544

**KENWOOD ELECTRONICS (MALAYSIA) SDN BHD**  
#4.01 Level 4, Wisma Academy Lot 4A, Jalan 19/1, 46300 Petaling Jaya, Selangor Darul Ehsan,  
Malaysia