

KDC-9023R KDC-PSW9524 KDC-X969 SERVICE MANUAL

CD mechanism operation description is not in this service manual.

Please, refer to service manual X92-4030-0x (B51-7867-00).

CD mechanism extension cord : W05-0935-00

Panel assy
(A64-2975-01): KDC-X969

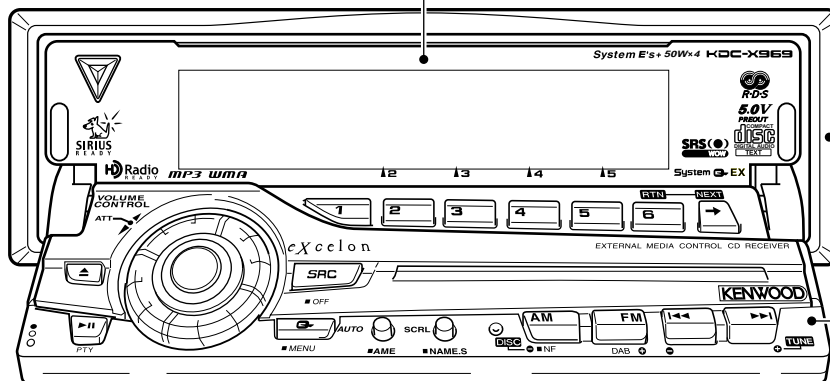

Escutcheon
(B07-3079-01)

Panel assy
(A64-2993-02):
KDC-X969

Panel assy
(A64-2982-01): KDC-9023R, (A64-2984-01):KDC-PSW9524

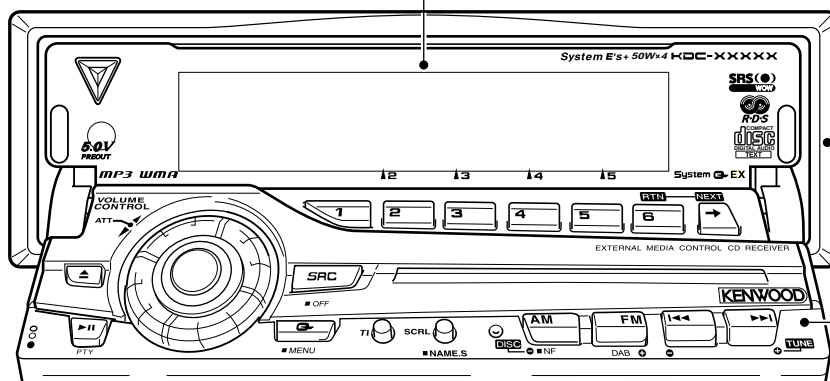

Escutcheon
(B07-3079-01)

Panel assy
(A64-3002-02):
KDC-9023R/PSW9524

Escutcheon
(B07-3079-01)

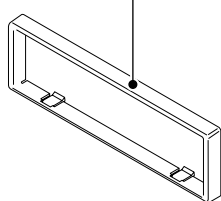

Mounting hardware assy
(J21-9823-03)

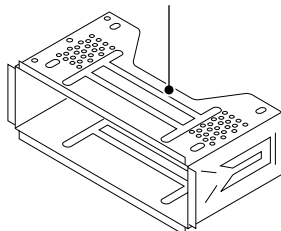

Plastic cabinet assy
(A02-2731-03)

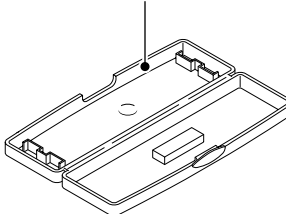

DC cord (ISO)
(E30-4942-05)
: KDC-9023R/PSW9524

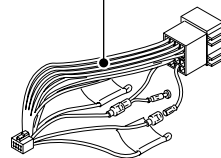

DC cord
(E30-6062-05)
: KDC-X969

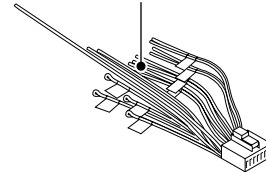

Remote controller assy
(RC-505)
(A70-2040-05)
: KDC-X969

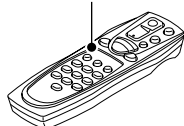

Remote controller assy
(RC-420)
(A70-2026-05)
: KDC-9023R/PSW9524

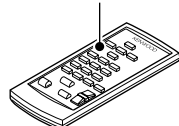

Lever
(D10-4674-04) x 2

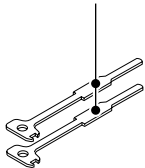

Size AA battery
(Not supplied)



Screw set
(N99-1723-05)
: KDC-X969/9023R

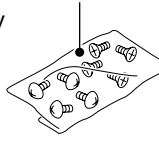

Antenna adaptor
(T90-0552-05)
: KDC-9023R/PSW9524

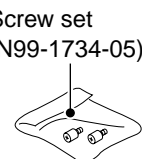

Screw set
(N99-1734-05)



HOW TO THE PANEL MECHANISM ASSEMBLY

1. Fixed the position of operation side

(Fixed the horizontal position when the panel opened)

- ① The mounting hardware (281) of operation side is rotation (A) into the stop position with close side.
- ② As figure (B) line is just above and the gear (230) attached to pin.

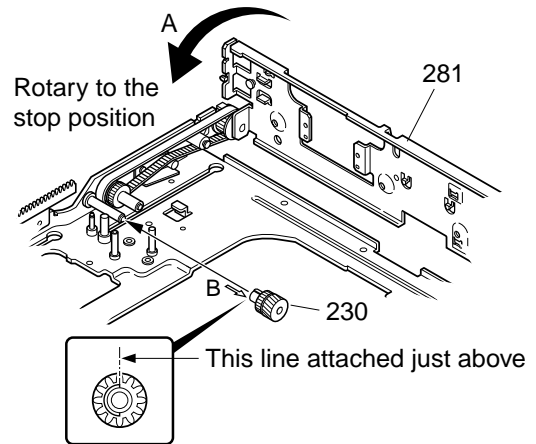

(This figure from look at B arrow)

2. The slider assembly insert to bottom chassis

- ① The bracket for display panel (284) is leave down, insert to the chassis (702). (C)

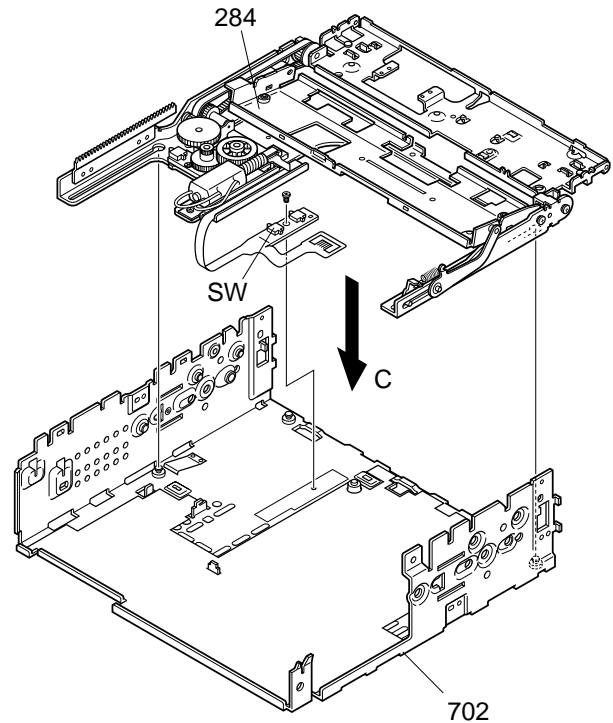

- ② The slider assembly insert to the chassis (702) after that shift (D) direction.
 - ③ The bracket for display panel (284) is raised (E) direction.
 - ④ Keep the raising conditions, the slider assembly is shift (F) direction.
- (Note) Do not bend the knob of chassis detection switch when the slider assembly insert.

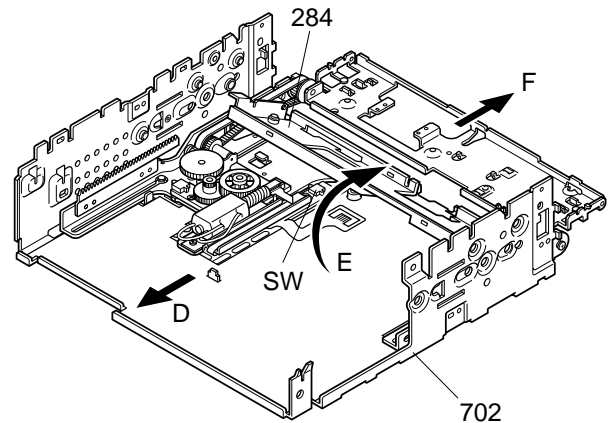

BLOCK DIAGRAM

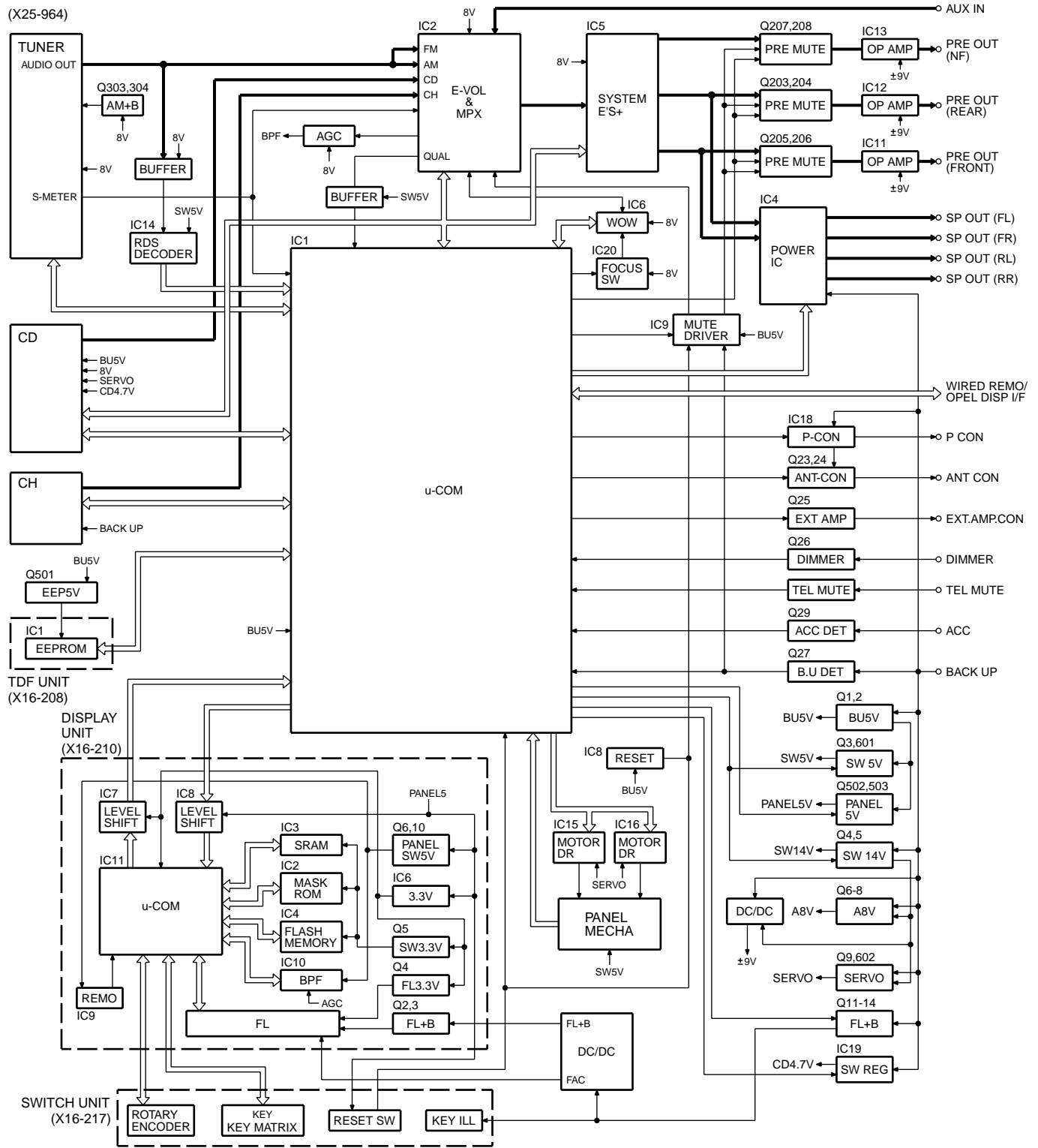

BLOCK DIAGRAM

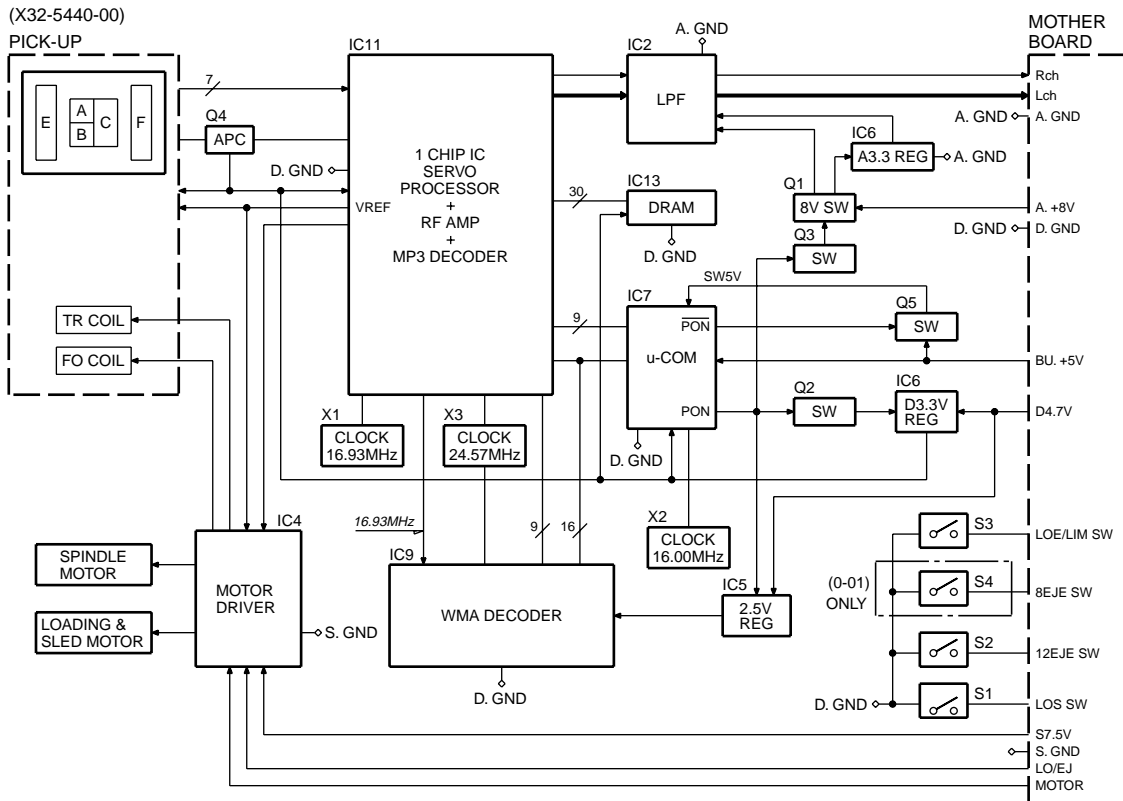

COMPONENTS DESCRIPTION

● SUB-CIRCUIT UNIT (X16-2080-10)

Ref. No.	Application/Function	Operation/Condition/Compatibility
IC1	E2PROM	For security

● SUB-CIRCUIT UNIT (X16-2100-10)

Ref. No.	Application/Function	Operation/Condition/Compatibility
IC2	ROM IC	
IC3	SRAM IC	
IC4	Flash ROM IC	For Display customize
IC5	Logic IC	For Write and Read to IC3
IC6	3.3V regulator	The power supply for 3.3V
IC7	Buffer IC	It is change into 3.3V from 5V
IC8	Buffer IC	It is change into 5V from 3.3V
IC9	Remote control IC	
IC10	Spectrum analyzer IC	
IC11	Panel μ -com	
Q1	3.3V regulator	While PAN 5V is applied, 3.3V regulator outputs +3.3V.

COMPONENTS DESCRIPTION

Ref. No.	Application/Function	Operation/Condition/Compatibility
Q2, 3	FL+B SW	FL+B (VDD2) is turned on when Q3's base level goes "H"
Q4	FL3.3V SW	FL+3.3V (VDD1) is turned on when Q4's base level goes "H"
Q5	3.3V SW	SW3.3V is turned on when Q5's base level goes "H"
Q6, 10	REMO ON SW	The power supply of IC9, 10 is turned on when Q10's base level goes "L"
Q7	FL BLK SW	VFD is turned on when Q7's base level goes "H"
Q8	Blue LED SW	Blue LED is turned on when Q8's base level goes "H"

● SWITCH UNIT (X16-2170-10)

Ref. No.	Application/Function	Operation/Condition/Compatibility
Q1	DSI (Disabled System Indicator)	DSI blinks when the base goes "H/L"
Q2	KEY illumination SW (GREEN)	ON (KEY illumination green) when the base goes "H"
Q3	KEY illumination SW (RED)	ON (KEY illumination red) when the base goes "H"

● ELECTRIC UNIT (X25-964x-xx)

Ref. No.	Application/Function	Operation/Condition/Compatibility
IC1	System μ -com	
IC2	E-vol & N.C. & MPX	
IC3	Regulator IC for A8V	
IC4	Power IC	
IC5	System E's IC	
IC6	Audio IC (WOW)	
IC7	-9V AVR (DC/DC IC) for 4.5V Pre-out	
IC8	Reset IC	
IC9	Logic IC for muting	
IC10	Buffer for S.A	
IC11~13	AMP for 4.5V Pre-out	
IC14	RDS decoder IC	
IC15, 16	Motor driver IC for panel mechanism	
IC17	ROM IC	For ROM correction.
IC18	P-CON IC	
IC19	Switching regulator IC for CD4.7V	
IC20	Analog SW for switching IC6'focus	
Q1, 2	B.U.5V AVR	While BU is applied, BU5V AVR outputs +5V.
Q3, 601	SW5V	When Q601'base goes Hi, SW5V outputs +5V.
Q4, 5	SW14V	When Q5'base goes Hi, SW14V outputs 14V.
Q6~8	AUDIO 8V AVR	When Q6'base goes Hi, A8V AVR outputs 8.3V.
Q9, 602	SERVO+B AVR	When Q602'base goes Hi, S+B AVR outputs 7.5V.
Q11~14	ILL&DC/DC+B AVR	When Q11'base goes Hi, AVR outputs 9.2V.
Q15, 16	AUDIO 10.5V AVR	When Q16'base goes Hi, AVR outputs 10.5V.
Q17~19	Pre-Amp -9V AVR	Q18 and 19 works as a differential amplifier, Q17 works as a driver and -9.1V is supplied to OP amp for Pre-out.

COMPONENTS DESCRIPTION

Ref. No.	Application/Function	Operation/Condition/Compatibility
Q20~22	Pre-Amp +9V AVR	Q20 and 22 works as a differential amplifier, Q21 works as a driver and +9.4V is supplied to OP amp for Pre-out.
Q23, 24	P-ANT SW	When Q23'base goes Hi, P-ANT SW outputs 14V.
Q25	Ex amp control buffer	
Q26	Small lamp det SW	When Q26'base goes Hi, Q26 is turned on.
Q27	BU det	When Q27'base gose Hi, Q27 is turned on.
Q29	ACC det	When Q29'base gose Hi, Q29 is turned on.
Q30, 31	Mute driver	When a base gose Lo, mute driver is turned on.
Q201	Noise buffer	
Q202	E-vol mute SW	When a base gose Hi, mute SW is turned on.
Q203~208	Pre-out mute SW	When a base gose Hi, Pre-out is muted.
Q210	AGC for SA	
Q303, 304	AM+B SW	When Q303'base gose Hi, AM+B is out.
Q305	Composite signal buffer for RDS	
Q501	E2P 5V SW	When Q501'base gose Lo, E2P 5V is out.
Q502, 503	PANEL 5V SW	When Q503'base gose Hi, PANEL 5V is out.
Q603	SW for IC20	When Q603'base gose Hi, Q603 is turned on.

● CD PLAYER UNIT (X32-5440-00)

Ref. No.	Application/Function	Operation/Condition/Compatibility
IC1	Audio 3.3V regulator	
IC2	Audio LPF	
IC4	BTL driver	
IC5	2.5V regulator	
IC6	3.3V regulator	
IC7	Mechanism control μ -com	
IC8	Level shift (3.3V \rightarrow 5V)	
IC9	WMA decoder	
IC10	WMA clock buffer	
IC11	CD signal processor LSI + RF amplifier + MP3 decoder	
IC12	WMA chip schmitt trigger	
IC13	Data buffer DRAM	
Q1	A.8V SW	When Q3 is on, Q1 is turned on.
Q2	3.3V regulator SW	When PON is on, Q2 is turned on.
Q3	A.8V SW	When PON is on, Q3 is turned on.
Q4	APC (Auto Power Control)	
Q5	D.5V SW	When PON is Lo, Q5 is turned on.
D1	Pick-up laser diode protection	
D2	Dropped out diode	

MICROCOMPUTER'S TERMINAL DESCRIPTION

● SYSTEM MICROCOMPUTER : 703033BGC020 (X25-964 : IC1)

Pin No.	Pin Name	I/O	Module	Purpose / Description	Truth table	Processing Operation
1	PLL_DATA	I/O	Tuner	Data output/input with F/E.		
2	AM+B	I/O	Power supply	AM+B.		AM operation : H
3	(FM+B)	O	Power supply	FM+B (S01 F/E only).		FM operation : H, Last FM : H (With RDS, RBDS model)
4	V_ILL PAN_E2P DATA	I/O	To panel	V-ILL D/A converter (V-ILL, LCD), E2PROM data.		
5	V_ILL PAN_E2P CLK	I/O	To panel	V-ILL D/A converter (V-ILL, LCD), E2PROM clock.		
6	EVDD	-				
7	EVSS	-				
8	AFS	O	Tuner	Noise detection time constant switching.		FM seek, AF search : L, Receiving : H, Auto 0 : L
9	BEEP	O	Audio	Beep output.		
10	REMO	I	Extra	Remote control input (Panel, External display).		
11	P_MUTE	O	Audio	Power IC MUTE output.		Power OFF : L, All OFF : L, TEL mute : L
12	(SVR)	O	Audio	Power IC SVR discharge circuit control.		Power OFF momentary power dropped : H (5 second) and then L
13	IC2_SDA	I/O	CD	CD mechanism data line.		
			Audio	IC2, IC5 data line.		
			Extra	ROM correction data line.		
14	IC2_CLK	I/O	CD	CD mechanism clock line.		
			Audio	IC2, IC5 clock line.		
			Extra	ROM correction clock line.		
15	P_STBY	O	Audio	Power IC STBY output.		Power IC ON : H, Power IC OFF : L, All OFF : H
16	P_CON	I/O	Extra	Power control.		Power ON : H, Power OFF : Hi-Z, All OFF : Hi-Z
17	WOW_MODE2	O	Audio	WOW control.	①	
18	TEST	-				Connect to GND.
19	DIAG	I	Extra	P_CONIC over voltage, over current detection.		Usually : H, Unusually : L
20	MUTE	O	Audio	Mute output.		ON : OPEN, OFF : L
21	PRE_MUTER	O	Audio	PREOUT (R ch) mute.		M MUTE L is L : L (CD), Momentary power dropped : L, 2 zone, NAVI interrupt : Fixed H
22	PRE_MUTEL	O	Audio	PREOUT (L ch) mute.		M MUTE R is L : L (CD), Momentary power dropped : L, 2 zone, NAVI interrupt : Fixed H
23	BU_DET	I	Extra	Momentary power dropped detection.		Backup : L, No backup, momentary power dropped : H
24	ACC_DET	I	Extra	ACC detection.		With ACC : L, Without ACC : H
25	FOCUS	I/O	Audio	WOW focus control.		Focus HI : H, Focus LOW : Hi-Z
26	EXT_AMP_CONT	O	Extra	External amplifier control.		Refer to external amplifier control.
27	DIMMER	I	Extra	Small lamp detection.		ON : L, OFF : H

MICROCOMPUTER'S TERMINAL DESCRIPTION

Pin No.	Pin Name	I/O	Module	Purpose / Description	Truth table	Processing Operation
28	ANT_CON	O	Extra	Antenna control.	②	Tuner ON : H, Other source With RDS last FM : H, Other source with RDBS TI ON last FM : H
	TYPE2	I	Extra	Destination select.	②	K,J type (With ANT_CON model) : L, E type (Without ANT_CON model) : H
29	P_ON	I/O	Power supply	SW 14V, SW 5V control, AD reference voltage control output.		Power ON : H, Power OFF : Hi-Z
30	ILL_ON	I/O	Power supply	FL, illumination output.		ON : H, OFF : Hi-Z
31	RESET	-				
32	XT1	-		Sub clock.		32.768kHz
33	XT2	-		Sub clock.		32.768kHz
34	REGC	-				Connect to 1 μ F capacitor.
35	X2	-		Main clock.		20MHz
36	X1	-		Main clock.		20MHz
37	VSS	-				
38	VDD	-				
39	CLKOUT	-				
40	LX_REQ_M	O	LX	Communication request to external slave.		Request : L
41	LX_MUTE	I	LX	Mute request from external slave.		Mute ON : H
42	LX_CON	O	LX	External slave select.		ON : H, OFF : L
43	LX_RST	O	LX	Reset output to external slave μ -com		Normally : L, After system reset : H (400ms or more) and then L
44	CD_MECHA+B	O	Power supply	CD 4.7V output.		CD source : H, Except CD source : L, ON : Fast 50ms than M_STOP, OFF : Slow 50ms than M_STOP
45	TYPE0	I	Extra	Destination select.	②	
46	TYPE1	I	Extra	Destination select.	②	
47	IC2_TYPE0	I	Extra	IC2 destination.	②	
48	IC2_TYPE1	I	Extra	IC2 destination.	②	
49	PAN5V	I/O	Power supply	Panel 5V control.		ON : H, Momentary power dropped : Hi-Z
50	E2P5V	I/O	Power supply	E2PROM, DA converter power supply control.		ON : L, OFF : Hi-Z
51	DSI	I/O	To panel	DSI control.		ON : L, OFF : Hi-Z
52	MC_REQ	O	To panel	Communication request to panel μ -com.		
53	PAN_RST	O	To panel	Reset output to panel μ -com.		Normally : H, Reset, momentary power dropped : L
54	WOW_MODE3	O	Audio	WOW control.	①	
55	BVDD	-				
56	BVSS	-				
57	SC_CON	O	To panel	Panel μ -com control.		Power OFF, ACC OFF : L
58	M_RST	O	CD	Reset output to CD mechanism.		Normally : H, Reset : L (Per mechanism control)
59	M_STOP	O	CD	Stop request to CD mechanism.		Stop : L, CD : H

MICROCOMPUTER'S TERMINAL DESCRIPTION

Pin No.	Pin Name	I/O	Module	Purpose / Description	Truth table	Processing Operation
60	CD_SW3	I	CD	DC down switch detection.		Chucking : H
61	LO/EJ	I/O	CD	CD mechanism loading/eject switch.		Stop, brake : Hi-Z, Loading : L, Eject : H
62	MOSW	O	CD	CD mechanism motor driver switch.		Loading, eject, brake : H
63	FPM MOTOR B	O	P-mecha	FPM mechanism (Slider) control.	③	
64	FPM MOTOR F	O	P-mecha	FPM mechanism (Slider) control.	③	
65	FPM MOTOR O	O	P-mecha	FPM mechanism (Angle) control.	③	
66	FPM MOTOR C	O	P-mecha	FPM mechanism (Angle) control.	③	
67	O_DATA	I/O	Extra	External display data input/output.		External display
	NC	O		NC (Without external display model)		Output : L
68	O_CLK	I/O	Extra	External display clock input/output.		External display
	NC	O		NC (Without external display model)		Output : L
69	O_CE	I/O	Extra	External display chip enable input/output.		External display
	NC	O		NC (Without external display model)		Output : L
70	M_MUTER	I	CD	Mute request form CD mechanism. (R ch).		ON : L (CD)
71	AVDD	-				
72	AVSS	-				
73	AVREF	-		Connect to P_ON (29 pin).		
74	M_MUTEL	I	CD	Mute request form CD mechanism. (L ch).		ON : L (CD)
75	PAN_DET	I	To panel	Panel E2PROM detection.		With : L, Without : H
76	PHONE	I	Extra	PHONE detection.		TEL mute : 1V or less, NAVI mute : 2.5V or more, J type 1V or less, 2.5V or more : NAVI mute
	NC	I		NC (Without TEL-MUTE model)		Connect to GND.
77	FPM SW4	I	P-mecha	FPM mechanism position detection, mechanism detection.	③	3.75V or more : No mechanism, 1.25V or more : H, Less than 1.25V : L
78	FPM SW1	I	P-mecha	FPM mechanism position detection.	③	
79	FPM SW2	I	P-mecha	FPM mechanism position detection.	③	
80	FPM SW3	I	P-mecha	FPM mechanism position detection.	③	
81	FPM PHOUT	I	P-mecha	FPM mechanism position detection.	③	H : 2.2V or more
82	S_METER	I	Tuner	S-meter detection.		Refer to S03 F/E control.
83	NOISE	I	Tuner	FM noise detection.		Refer to S03 F/E control.
84	IFC_OUT	I	Tuner	F/E IFC OUT input.		With station : 2.5V or more, refer to S03 F/E control.
85	NC (POWER_DET)	I	Extra	Power IC DC offset detection.		03 model not used. Connect to GND.
86	NC	O		NC		Output : L
87	R_CLK	I	Tuner	RDS decoder clock input.		
88	LX_REQ_S	I	LX	Receive request from external slave.		Request : L
89	SC_REQ	I	To panel	Communication request from panel μ -com		
90	CD_SW1	I	CD	Loading switch detection.		Loading start power off : L
91	CD_SW2	I	CD	12cm disc detection switch.		12cm disc power off : L
92	R_QUAL	I	Tuner	RDS decoder QUAL input.		

MICROCOMPUTER'S TERMINAL DESCRIPTION

Pin No.	Pin Name	I/O	Module	Purpose / Description	Truth table	Processing Operation
93	R_DATA	I	Tuner	RDS decoder data input.		
94	LX_DATA_S	I	LX	Data input from external slave.		
95	LX_DATA_M	O	LX	Data output to external slave.		
96	LX_CLK	I/O	LX	Clock input/output with external slave.		
97	PAN_RX	I	To panel	Data input from panel μ -com		
98	PAN_TX	O	To panel	Data output to panel μ -com		
99	WOW_MODE1	O	Audio	WOW control.	①	
100	PLL_CLK	I/O	Tuner	Clock input/output with F/E.		

Truth table

① WOW MODE changover operation

MODE	WOW_MODE1	WOW_MODE2	WOW_MODE3	FOCUS
BYPASS	L	L	L	Don't care
TruBass	L	H	L	Don't care
3D-STEREO	L	L	H	Don't care
FOCUS LOW	H	L	L	L (Hi-z)
FOCUS HI	H	L	L	H
WOW LOW	H	H	H	L (Hi-z)
WOW HI	H	H	H	H

② Destination port

MODEL	Destination	DISPLAY	TYPE2	TYPE1	TYPE0
KDC-X969	K	FL	0	0	0
KDC-MP922	K	FL	0	0	1
FX-9000	J	FL	0	1	0
KDC-PSW9524	E	FL	1	0	0
KDC-9023R	M (E)	FL	1	0	1
KDC-X869	K	FL	0	1	1
KDC-8024	E	FL	-	-	-
KDC-MP822	K	LCD	-	0	0
KDC-M7024	E	LCD	-	0	1
FX-5000	J	LCD	-	1	0
KDC-V7022	K	LCD	0	0	0
KDC-X769	K	LCD	0	0	1
KDC-722	K	LCD	0	1	0
KDC-7024	E	LCD	0	1	1
KDC-7024Y					
KDC-8023	M (K)	LCD	1	0	0

Note : When FL model using TYPE2, K & J type (with ANT_CON model) : L, E type (without ANT_CON model) : H

MICROCOMPUTER'S TERMINAL DESCRIPTION

Destination(IC2)

	TYPE0	TYPE1
Market model	L	L
Market model CRSC modification	L	H
OEM model CRSC modification	H	L
OEM model CRSC and de-emphasis modification	H	H

③ FPM MOTOR

Slide		FPM mechanism operation
FPM MOTOR B	FPM MOTOR F	
0	0	Standby
1	0	Backward operation
0	1	Forward operation
1	1	Brake

Angle		FPM mechanism operation
FPM MOTOR O	FPM MOTOR C	
0	0	Standby
1	0	Angle open direction
0	1	Angle close direction
1	1	Brake

MICROCOMPUTER'S TERMINAL DESCRIPTION

● PANEL MICROCOMPUTER : 703107AGJ152 (X16-210 : IC11)

Pin No.	Pin Name	I/O	Purpose / Description	Processing Operation
1~7	D14~D8	I/O	External ROM data.	
8	3.3V VDD	-	PAN 3.3V	
9	VSS	-	Vss	
10~17	D7~D0	I/O	External ROM data.	
18	MODE2	I	Use for μ -com rewriting.	Connect to GND
19	OPEN KEY	I	OPEN key	H : OFF, L : ON
20	SRC KEY	I	SOURCE key	H : OFF, L : ON
21	SC CON	I	Panel μ -com control.	H : While operation (Reset, low current consumption mode : System μ -com output "L")
22	NC	O		Output : L
23	FL LATCH	O	Latch output to FL driver.	
24	FL GCP	O	Bright control.	
25, 26	NC	O		Output : L
27	3.3V VDD	-	PAN 3.3V	
28	VSS	-	Vss	
29~33	KR1~KR5	I	Key return.	
34	VOL A	I	VOL input.	
35	VOL B	I	VOL input.	
36	NC	O		Output : L
37	3.3V VDD	-	PAN 3.3V	
38	VSS	-	Vss	
39~42	KS1~KS4	I/O	Key scan.	Key scan (Hi-Z/L)
43	FL BLK	O	Display switching signal output to FL driver.	H : Display ON, L : Display OFF (Digital transistor is inserted)
44, 45	NC	O		Output : L
46	NC	I		Connect to GND
47	3.3V VDD	-	PAN 3.3V	
48	VSS	-	Vss	
49	FCS	O	Flash ROM chip enable.	L : Data communication
50	MC REQ	I	System μ -com request input.	H : Request (Reset, low current consumption mode : System μ -com output "L")
51	SC REQ	O	Communication request to system μ -com.	H : Request
52	SYS TX	I	Data input from system μ -com.	(Reset, low current consumption mode : System μ -com output "L")
53	SYS RX	O	Data output to system μ -com.	Communication speed : 1.25Mbps
54	FCLK	O	Clock output to flash ROM.	Communication speed : 3.125MHz
55	FDATAIN	I	Data input from flash ROM.	
56	FDATAOUT	O	Data output to flash ROM.	
57	MODE1	I	μ -com operation mode setting.	
58	MODE0	I	μ -com operation mode setting.	

MICROCOMPUTER'S TERMINAL DESCRIPTION

Pin No.	Pin Name	I/O	Purpose / Description	Processing Operation
59	PAN RST	-		
60	CKSEL	-	Clock generator operation mode.	Connect to GND
61	3.3V VDD	-	PAN 3.3V	
62	X2	-	Main clock	5MHz
63	X1	-	main clock	5MHz
64	VSS	-	Vss	
65	FL CLK	O	Clock output to FL driver.	Communication speed : 3.125MHz
66	NC	O		Output : L
67	FL DATA2	O	Data output to FL driver.	
68	CLK IN	I	Clock input from FL driver.	Connect to 65 pin (Write : CLK). Reset, low current consumption mode : FL CLK output "L"
69	NC	O		Output : L (Write : SI)
70	FL DATA1	O	Data output to FL driver.	(Write : SO)
71	AVREF	-	AVREF	
72	VSS	-	Vss	
73	NC	I		Connent to GND
74	WAVE IN	I	Audio input.	A/D input is not over maximum voltage by 33kΩ resistor pull-down.
75	F06	I	BPF (10kHz)	A/D input is not over maximum voltage by 47kΩ resistor pull-down.
76	F05	I	BPF (3.3kHz)	A/D input is not over maximum voltage by 47kΩ resistor pull-down.
77	F04	I	BPF (1kHz)	A/D input is not over maximum voltage by 47kΩ resistor pull-down.
78	F03	I	BPF (330Hz)	A/D input is not over maximum voltage by 47kΩ resistor pull-down.
79	F02	I	BPF (150Hz)	A/D input is not over maximum voltage by 47kΩ resistor pull-down.
80	F01	I	BPF (63Hz)	A/D input is not over maximum voltage by 47kΩ resistor pull-down.
81	3.3V VDD	-	PAN 3.3V	
82	VSS	-	Vss	
83	VREF CON	O	VREF control.	Connect to AVREF
84	SA RST	O	Spectrum analyzer IC reset.	H : Reset, L : Normally (Spectrum analyzer IC'RST : 1.8V or more)
85	REMO ON	I/O	Remote control IC power ON/OFF.	H : ON, Hi-Z : OFF (Time constant check, Normal temperature : 500μs)
86	NC	O		Output : L
87	3.3V SW	I/O	3.3V ON/OFF.	H : ON, Hi-Z : OFF (Time constant check, Normal temperature : 250μs)
88	FL3.3V SW	I/O	FL3.3V ON/OFF.	H : ON, Hi-Z : OFF (Time constant check, Normal temperature : 500μs)
89	FL+B SW	I/O	FL+B ON/OFF.	H : ON, Hi-Z : OFF (Time constant check, Normal temperature : 35μs)
90	BLUE LED	O	Blue LED ON/OFF.	H : ON, L : OFF
91~94	NC	O		Output : L
95	OE/RD	I/O	SRAM, ROM output enable.	L : Data communication, Hi-Z : Standby
96	WE/WR	I/O	SRAM Write/Read.	L : Data writing, Hi-Z : Standby
97	UWE/LWR	I/O	SRAM Write/Read.	L : Data writing, Hi-Z : Standby
98	3.3V VDD		PAN 3.3V	
99	VSS		Vss	

MICROCOMPUTER'S TERMINAL DESCRIPTION

Pin No.	Pin Name	I/O	Purpose / Description	Processing Operation
100	NC	O		Output : L
101	SRAM CHECK	O	SRAM write check.	OK : L, NG : L (Check land necessary)
102	FLASHROM CHECK	O	Flash ROM write check.	OK : L, NG : L (Check land necessary)
103	NC	O		Output : L
104	CS ROM	I/O	ROM chip enable.	L : Data communication, Hi-Z : waiting
105	NC	O		Output : L
106	CS RAM	I/O	SRAM chip enable.	L : Data communication, Hi-Z : waiting
107	NC	O		Output : L
108	UBE	I/O	SRAM Write/Read.	L : Prohibit, Hi-Z : Inhibit
109	LBE	I/O	SRAM Write/Read.	L : Prohibit, Hi-Z : Inhibit
110	RED LED	O	Illumination red changeover.	H : ON, L : OFF
111	GREEN LED	O	Illumination green changeover.	H : ON, L : OFF
112	3.3V VDD	-	PAN 3.3V	
113	VSS	-	Vss	
114~117	NC	O		Output : L
118~123	A20~A15	I/O	Address	Not access : Hi-Z
124	3.3V VDD	-	PAN 3.3V	
125	VSS	-	Vss	
126~133	A14~A7	I/O	Address	Not access : Hi-Z
134	3.3V VDD	-	PAN 3.3V	
135	VSS	-	Vss	
136~142	A6~A0	I/O	Address	Not access : Hi-Z
143	NC	O		Output : L
144	D15	I/O	External ROM data.	

MICROCOMPUTER'S TERMINAL DESCRIPTION

● MECHANISM MICROCOMPUTER : 703030BYGC-J02 (X32-544 : IC7)

Pin No.	Pin Name	I/O	Use	Processing Operation	STBY Processing
1	NC	O	Not used.	Fixed Low	Low
2	E2P_SCL	O	ROM correction E2P IC2 clock.		Hi-Z
3~5	NC	O	Not used.	Fixed Low	Low
6	VDD	-	5V		
7	GND	-	GND		
8, 9	NC	O	Not used.	Fixed Low	Low
10	PON	O	Power ON/OFF control.	H : ON, L : OFF	Low
11	/PON	O	Power ON/OFF control.	H : OFF, L : ON	High
12	LOE/LIM_SW	I	Down limit switch detection.	L : Most Inner position detection	Hi-Z
13	8EjE_SW	I	Not used.	Fixed Low	Hi-Z
14	LOS_SW	I	Not used.	Fixed Low	Hi-Z
15	12EjE_SW	I	Not used.	Fixed Low	Hi-Z
16, 17	NC	O	Not used.	Fixed Low	Low
18	IC/Vpp	-	Write voltage (Flash).		-
19	MUTE_L	O	L ch audio mute control.	L : Mute ON, H : Mute OFF	Low
20	MUTE_R	O	R ch audio mute control.	L : Mute ON, H : Mute OFF	Low
21~25	NC	O	Not used.	Fixed Low	Low
26	EFLG	I	WMA error detection.	H : Error, L : No error	Hi-Z
27	WAIT	I	Wait control signal detection.		Hi-Z
28	FOK	I	Focus condition detection.	H : Focus OK, L : Focus NG	Hi-Z
29, 30	NC	O	Not used.	Fixed Low	Low
31	RESET	I	Reset detection.	H : Normal, L : Reset	Hi-Z
32	XT1	I	Not used.		Hi-Z
33	XT2	-	Not used.		-
34	REGC	-			
35	X2	-			
36	X1	I			Hi-Z
37	Vss	-	GND		
38	VDD	-	5V		
39	NC	O	NC	Output stop.	Low
40	WRL	O	Multiplex WRITE signal.	_LBEN : 61002 (Not used), _WRL : 63760	Out-Low
41	NC	O	Not used.	Fixed Low	Low
42	R/W	O	Multiplex _R/W signal	_R/W : 61002, _WRH : 63760 (Not used)	Out-Low
43	DSTB,RD	O	Multiplex DSTB or RD signal	_DSTB : 61002, _RD : 63760	Out-Low
44	ASTB	O	Multiplex ASTB signal		Out-Low
45, 46	NC	O	Not used.	Fixed Low	Low
47~54	AD0~AD7	I/O	Multiplex address/data		Out-Low
55	BVdd	-	Bus interface power supply.		

MICROCOMPUTER'S TERMINAL DESCRIPTION

Pin No.	Pin Name	I/O	Use	Processing Operation	STBY Processing
56	BVss	-	Bus interface GND.		
57~64	AD8~AD15	I/O	Multiplex data/address		Out-Low
65	/HCSB	O	Chip select control.	H : OFF, L : ON	Low
66	/CS	O	Chip select control.	H : OFF, L : ON	Low
67	DSP RESET	O	DSP reset control.	H : Normal. L : Reset	Low
68	REQ	I	Data transfer request input.		Hi-Z
69	DBBWRDY0	I	DBB00 register write permission input.		Hi-Z
70	DBBRRDY0	I	DBB00 register read permission input.		Hi-Z
71	Avdd	-			
72	Avss	-			
73	Avref	I	A/D port reference voltage input.		
74	WTS	I	WMA table select.	H : WMA8 table, L : WMA9 table	Hi-Z
75	MDL_SEL	I	Model port changeover.	H : 03 model, L : 02 model	Hi-Z
76, 77	NC	I	Not used.	Fixed Low	Hi-Z
78	HOT	I	Temperature rise detection.	Detection voltage : 4V, Reset voltage 3.9V	Hi-Z
79	NC	I	Not used.	Fixed Low	Hi-Z
80	WMA	I	WMA correspond changeover.	H : DXM6500 (With WMA), L : DXM6400 (Without WMA)	Hi-Z
81	NC	I	Not used.		Hi-Z
82	ASEL	I	Audio output pole changeover.	H : Invert output, L : Normal output	Hi-Z
83	DASC	I	Shock proof changeover.	H : Shock proof OFF, L : Shock proof ON	Hi-Z
84	E2P_WR	I	E2PROM write changeover.	H : E2PROM write, L : Normal	Hi-Z
85	PIC_SEL	I	PICK UP changeover.	H : KPC6C, L : KSS710	Hi-Z
86	NC	O	Not used.	Fixed Low	Low
87	MSTOP	I	Standby restart interrupt.	H : Standby, L : Stop	Hi-Z (Low input)
88	INTSV	I	Servo IC interrupt.	H : Interrupt	Hi-Z
89	FOGUP	I	Focus gain up interrupt.	H : Focus gain up, L : Normal	Hi-Z
90	ZMUTE_R	I	0 bit mute detection.	H : Mute ON, L : Mute OFF	Hi-Z
91	ZMUTE_L	I	0 bit mute detection.	H : Mute ON, L : Mute OFF	Hi-Z
92	NC	O	Not used.	Fixed Low	Low
93	D-MUTE	O	Driver mute.	H : OFF, L : ON	Low
94	SYS_SDA	I/O	System μ -com I2C data.		Hi-Z
95	NC	O	Not used.	Fixed Low	Low
96	SYS_SCL	I/O	System μ -com I2C clock.		Hi-Z
97~99	NC	O	Not used.	Fixed Low	Low
100	E2P_SDA	O	ROM correction E2P I2C data.		Hi-Z

TEST MODE

● How to enter the test mode

While pressing and holding the Preset 1 and Preset 3 keys, reset the unit.

● How to exit from the test mode

While holding the Preset 6 key, reset the unit.

(Note) The test mode cannot be terminated by reset the unit, ACC OFF, power OFF and Panel detached, momentary power down.

● Initial status in the test mode

- Sources : ALL OFF
- Display : All segments are lit.
- Volume : -10 dB (displayed as "30")
- Loudness : OFF
- CRSC : OFF regardless of the presence of switching function.
- SYSTEM Q : Flat
- WOW : All OFF
- BEEP : When pressing any keys, the buzzer generates a beep at any time.
- AUX : ON
- MENU SYSTEM Q : OFF
- Variable model : Default is white
- Multifunction : Source dependency (Preset, SCAN, etc.)

● Special display in Tuner mode

When any of the following messages is displayed in Tuner mode, the F/E may be abnormal.

- "TNE2P NG" : The EEPROM is set to the default (unstable values) because the F/E was shipped without passing through the adjustment process, etc.
- "TNCON NG" : Communication with the F/E is not possible.

● Forced switching of K3I

Each press of the Preset 6 key in Tuner mode should switch K3I from AUTO → Forced Wide → Forced Middle → Forced Narrow → AUTO.

The initial status is AUTO and the display shows these modes as follows.

- AUTO : FMA
- Forced Wide : FMW
- Forced Middle : FMM
- Forced Narrow : FMN

● Test mode specifications of the CD receiver

- Forced ejection is inhibited in the reset start operation. When the unit is reset while a CD is loaded in it, the CD is not recognized by resetting.
- Each press of the Track Up key jumps to the following track numbers:
No. 9 → No. 15 → No. 10 → No. 11 → No. 12 → No. 13 → No. 22 → No. 14 → No. 9 (The cycle restarts from here.)
- Each press of the Track Down key jumps to the previous track number to the track being played.
- When the number of total tracks of the MP3 disc or the WMA disc is less than 9, 1st track is played.
- When the disc media is CD, A short press of the Preset 1 key jumps to the track number 28.
- When the model is equipped the CD mechanism assembly adapted for MP3 or MP3/WMA disc, the mechanism name and version number are displayed during the FL model is lower stand and Display mode of LCD model is DNPS.

● Audio-related specifications

- Pressing the * key on the remote initiates the audio adjustment mode.
- BL/F key on the Fader initials.
- Continuous holding of a remote control key is inhibited, and workings are short press of any keys.
- Bass, Middle and Treble are adjusted in 3 steps of -8 / 0 / +8 with the Track Up/Down keys (Default value at 0).
- Balance is adjusted in 3 steps of L15 / 0 / R15 with the Track Up/Down keys (Default value at 0).
- Fader is adjusted in 3 steps of R15 / 0 / F15 with the Track Up/Down keys (Default value at 0).
- HPF is adjusted in 2 steps of OFF / 170Hz (or 220Hz) with the Track Up/Down keys (Default value at OFF).
- LPF is adjusted in 2 steps of OFF / 120Hz with the Track Up/Down keys (Default value at OFF).
- Bass f, Bass Q, Bass EXT, Middle f, Middle Q and Treble f are not dealt with by the audio adjust.
- The WOW key pass during the audio adjustment as following steps.

Order	Mod.			Display
	TruBass	FOCUS	SRS	
①	OFF	OFF	OFF	SRS WOW OFF
②	ON	OFF	OFF	SRS TruBass ON
③	OFF	LOW	OFF	FOCUS LOW
④	OFF	HIGH	OFF	FOCUS HIGH
⑤	OFF	OFF	ON	SRS ON
⑥	ON	HIGH	ON	SRS WOW HIGH

TEST MODE

● Menu-related specifications

- A short press of the Q key initiates the menu mode.
- Pressing the DNPP key on the remote initiates the Menu mode.
- Continuous holding of a remote control key is inhibited, and workings are short press of any keys.
- Contrast is adjusted in 3 steps of 0 / 5 / 10 with the Track Up/Down keys (Default value at 5).

● Backup current measurement

When the unit is reset while ACC is OFF (i.e. by turning Backup ON), the MUTE terminal goes OFF in 2 seconds in place of 15 second. (The CD mechanism is not activated at this time.)

● Special display when the display is all on

Pressing the Preset keys while the power is ALL OFF displays the following information.

[PRESET 1]	Version display (8 digits, Month/Day/Hour/Minute) (Display) SYS xxxxxxxx : System microcomputer PAN xxxxxxxx : FL model only MEM xxxxxxxx : 4 contrasts FL model only
[PRESET 2]	Serial number display (8 digits) (Display) SNo xxxxxxxx
[PRESET 3]	Short press : View power ON time. (The All OFF period is not counted.) 2 seconds long press/hold : Clear power ON time at the power ON time displaying. (Display) PonTim xxxxx Max. 60000 (hours)
[PRESET 4]	Short press : Display CD operation time. 2 seconds long press/hold : Clear CD operation time at the CD operation time displaying. (Display) CDTim xxxxx Max. 60000 (hours)
[PRESET 5]	Short press : Display CD ejection count. 2 seconds long press/hold : Clear CD ejection count at the CD ejection count displaying. (Display) EjeCnt xxxxx Max. 60000 (times)
[PRESET 6]	Short press : Display Panel open/close count. 2 seconds long press/hold : Clear Panel open/close count at the Panel open/close count. (Display) PnCnt xxxxx Max. 600000 (times)
FM key	Display ROM collection version. (Display) ROM R xxx Invalid : "R --"
AM key	Display panel E2PROM condition. (Display) P-ROM OK (Registered code) P-ROM NG (Code is write in error) P-ROM WAIT (Unregistered code) P-ROM NON (Panel security nonfunctional)

● Panel mechanism

- Auto-panel close inhibition when set-in the CD.
- The panel operation inhibition at power ON/OFF and ACC ON/OFF.
- The panel position changing Eject ↔ Last with a short press of the PLAY/PAUSE keys.

● Other specifications

- No displays such as "CODE OFF/ON" during Power-ON.
- The LINE MUTE inhibition time is one second from 10 seconds when start-up the test mode.
- Do not write the security code with the security jig on the test mode.
- Do not write the serial with the serial writing jig on the test mode.
- OEM display output is not stop if OEM display not connection on the test mode.

● Switching the frequency span (K/M type)

While holding the Preset 1 key and Preset 5 key, reset the unit.

● Response to OEM setting

(Destination of electronic volume setting)

S03F/E models are response to OEM models option at put in μ -com 2 pin.

Its setting are following steps.

IC2TYPE0 (47 pin)	IC2TYPE1 (48 pin)	Description
Low	Low	① Trade model (Initial quantify)
Low	High	② Trade model (CRSC change)
High	Low	③ OEM model-ready CRSC change
High	High	④ OEM model-ready CRSC & de-emphasis change

● Security-related information

1. Forced Power ON mode (All models)

Even when the security (Cord) is approved, resetting the unit while holding the Q and Preset 4 keys makes it possible to turn the power ON for 30 minutes.

After 30 minutes have elapsed, it is not possible to return to the previous condition unless the unit is reset again. (Security code is do not clear at this mode. Put the power on fill-in.)

TEST MODE

2. Method of registration of the security code after EEPROM (F/E) replacement (Code security model)

- 1) Enter the test mode. (See How to enter the test mode)
- 2) Press the MENU key to enter the Menu mode.
- 3) When the message "Security" is displayed, press and hold the Track Up/Down key for 1 second to enter the security registration mode.
- 4) Enter the code using the FM/AM/Track Up/Track Down keys.
FM key : Number up
AM key : Number down
Track Up key : Cursor right shift
Track Down key : Cursor left shift
- 5) Hold down the Track Up key for at least 3 seconds and the message, "RE-ENTER" appears, so once again enter the code according to Step 4 above.
- 6) Press and hold the Track Up key for 3 seconds until "AP-PROVED" is displayed.
- 7) Exit from the test mode. (See 2. How to exit from the test mode)
(Note 1) All Clear is not applicable to the security code of this model.
(Note 2) When the F/E changed, need re-inscription because the panel security is clear.

3. Simple way to clear the security code (K type only)

- 1) During code request mode, press the Track UP key for at least 3 seconds while holding down the AUTO key. (--- will disappear)
- 2) Enter, "KCAR" with the remote controller as described below.
 - Press the remote controller 5 key twice, and press the Track Up key. (Enters a "K")
 - Press the remote controller 2 key three times, and press the Track Up key. (Enters a "C")
 - Press the remote controller 2 key once, and press the Track Up key. (Enters an "A")
 - Press the remote controller 7 key twice, and press the Track Up key. (Enters an "R")
- 3) Security function is canceled and unit sets to All-Off mode.
- 4) Code request mode appears if a mistake was made in entering the numbers.

4. How to inscription the panel security code

- 1) Enter the test mode.
- 2) Pressing the AM key on all lighting, check the "P-ROM WAIT" display.
- 3) The NEXT key is long press 2 seconds, writing the code.
- 4) Display is "P-ROM OK".
- 5) Exit from the test mode.
(Note) E2PROM connection is NG when display is "P-ROM NG", so detach the panel and rewrite after the display is "P-ROM WAIT". This code can not clear.

● Check the SRAM

Output (Hi) to the SRAM_CHECK terminal on 101 pin when SRAM is function properly on the panel of 4 gradation FL models.

● Check the Flash ROM

- 1) Display to the following effect at ALL OFF by assortment system computer and panel for cover the customization model attach the panel with no Flash ROM.
 - Customization system computer + Flash ROM panel : All lighting
 - Non customization system computer + Non Flash ROM panel : All lighting
 - Customization system computer + Non Flash ROM panel : Panel NG
 - Non customization system computer + Flash ROM panel : Panel NG
- 2) Output (Hi) to the FLASHROM_CHECK terminal on 102 pin when Flash ROM is function properly.
- 3) Flash ROM data is initialized when pressing the AM key long hold at all lighting.
Display is "Data Erase" in data erasing mode. Do not touch anything this mode. When the data erase completed, display is "Erase OK!!".
If display is "Erase NG!!!!!!", Flash ROM data unable erase for some kind or another factors.
When same effect as pressing the AM key long hold and data erase once again, Flash ROM is defective.

KDC-9023R
/PSW9524/X969

PC BOARD (COMPONENT SIDE VIEW)

ELECTRIC UNIT X25-964x-xx (J74-1473-12)

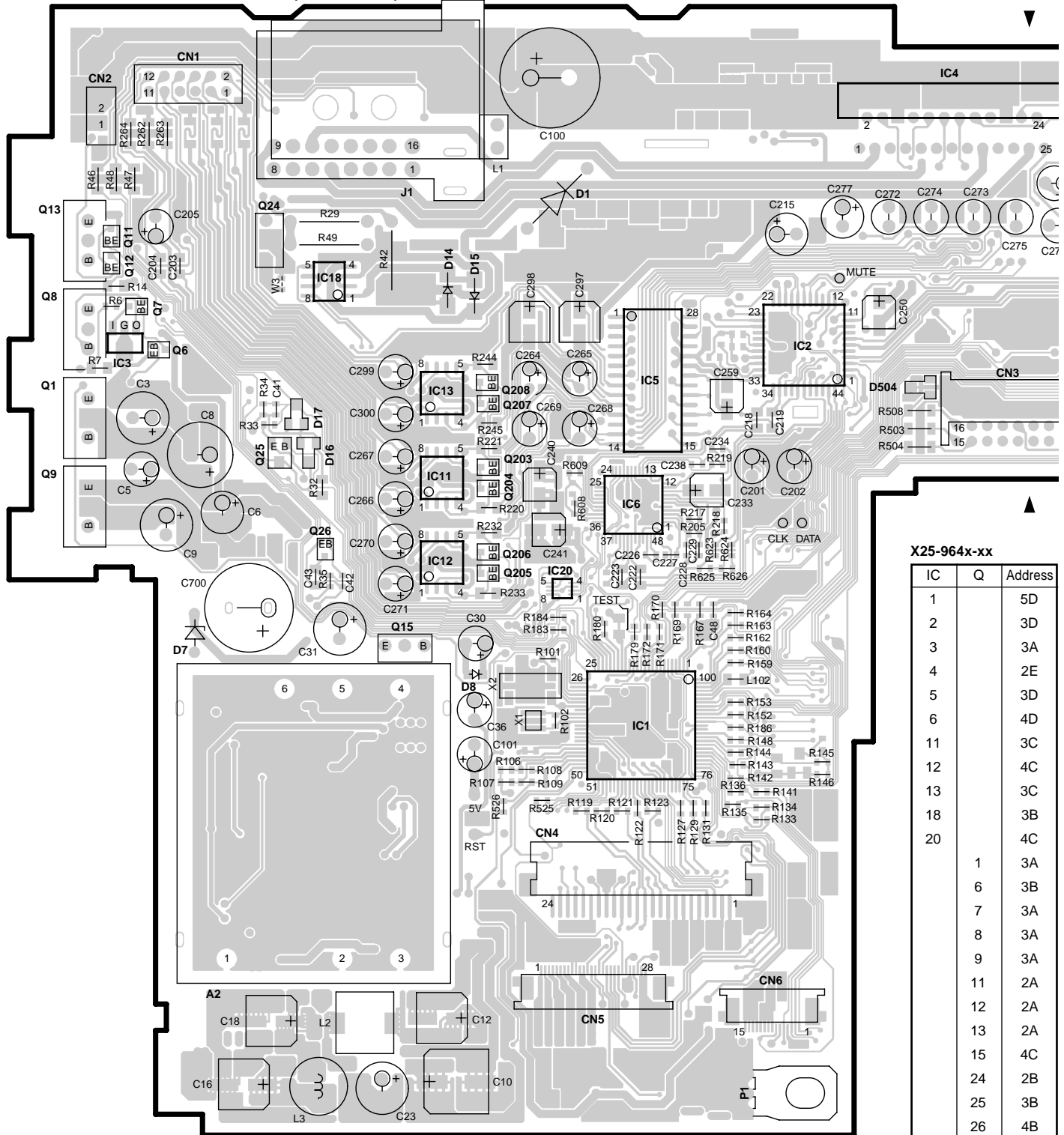

X25-964x-xx

IC	Q	Address
1		5D
2		3D
3		3A
4		2E
5		3D
6		4D
11		3C
12		4C
13		3C
18		3B
20		4C
	1	3A
	6	3B
	7	3A
	8	3A
	9	3A
	11	2A
	12	2A
	13	2A
	15	4C
	24	2B
	25	3B
	26	4B
	203	3C
	204	3C
	205	4C
	206	4C
	207	3C
	208	3C
	305	4F

Refer to the schematic diagram for the values of resistors and capacitors.

KDC-9023R /PSW9524/X969

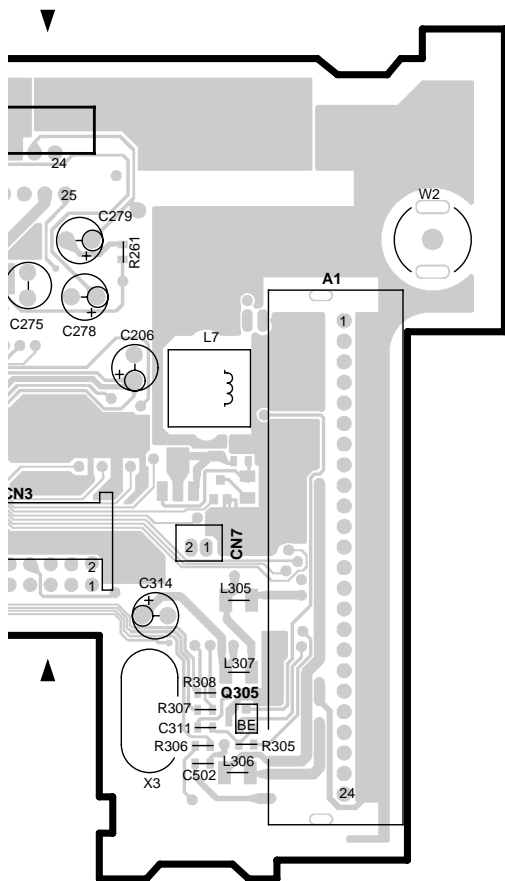

SUB-CIRCUIT UNIT
X16-2100-10 (J74-1477-12)

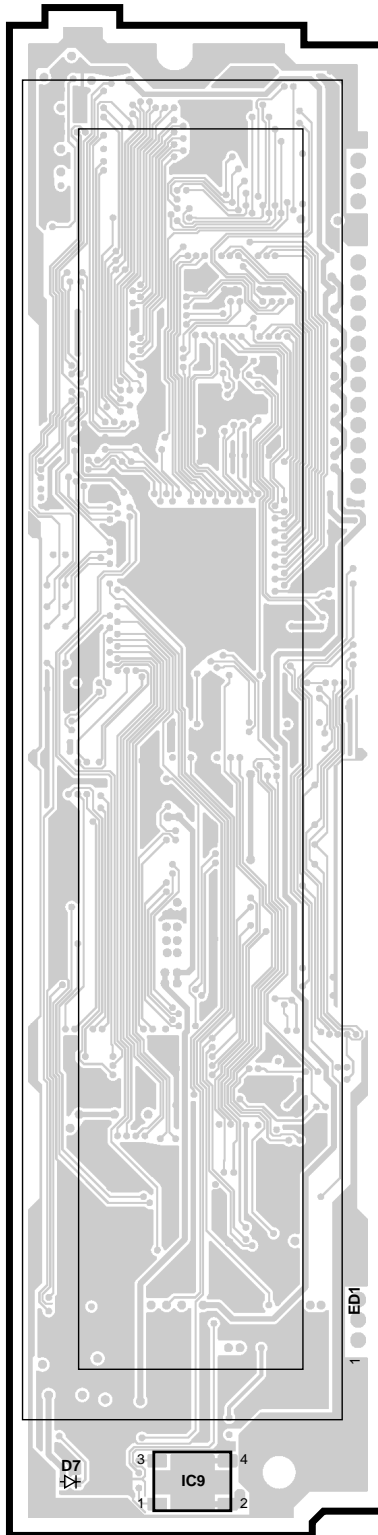

SWITCH UNIT
X16-2170-10 (J74-1482-12)

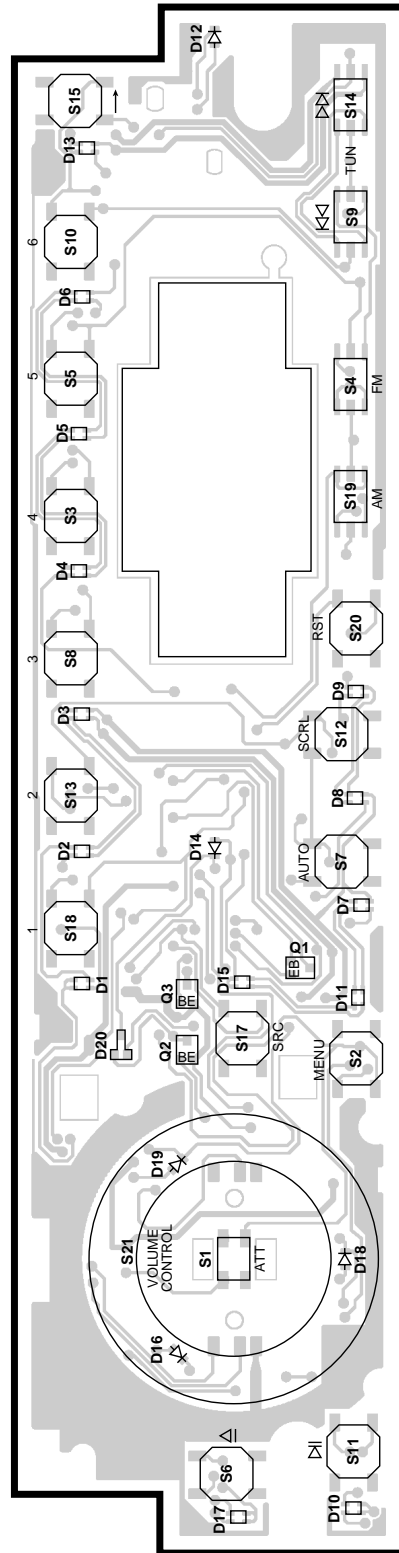

X16-2100-10

IC	Address
9	6H

X16-2170-10

Q	Address
1	5J
2	5I
3	5I

KDC-9023R /PSW9524/X969

PC BOARD (FOIL SIDE VIEW)

ELECTRIC UNIT X25-964x-xx (J74-1473-12)

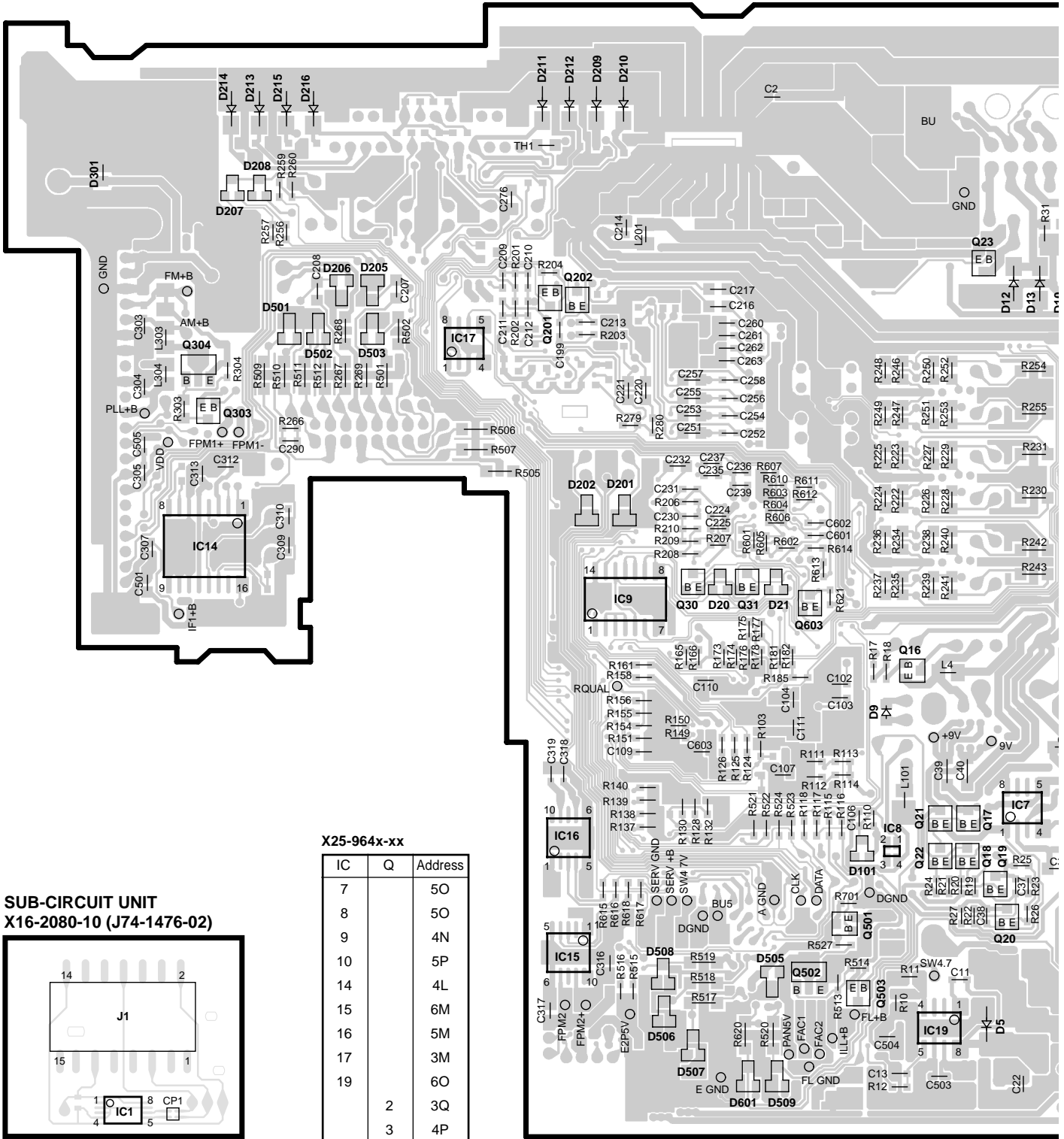

SUB-CIRCUIT UNIT X16-2080-10 (J74-1476-02)

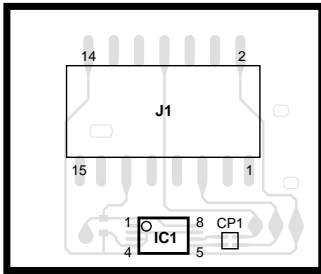

X16-2080-10

IC	Address
1	6K

X25-964x-xx

IC	Q	Address
7		5O
8		5O
9		4N
10		5P
14		4L
15		6M
16		5M
17		3M
19		6O
2	3Q	
3	4P	
4	3Q	
5	3Q	
14	3Q	
16	4O	
17	5O	
18	5O	
19	5O	
20	5O	

IC	Q	Address	IC	Q	Address	IC	Q	Address
	21	5O		31	4N		501	5O
	22	5O		201	3M		502	6N
	23	2O		202	3M		503	6O
	27	3P		210	5P		601	3P
	29	3P		303	3L		602	4Q
	30	4N		304	3L		603	4N

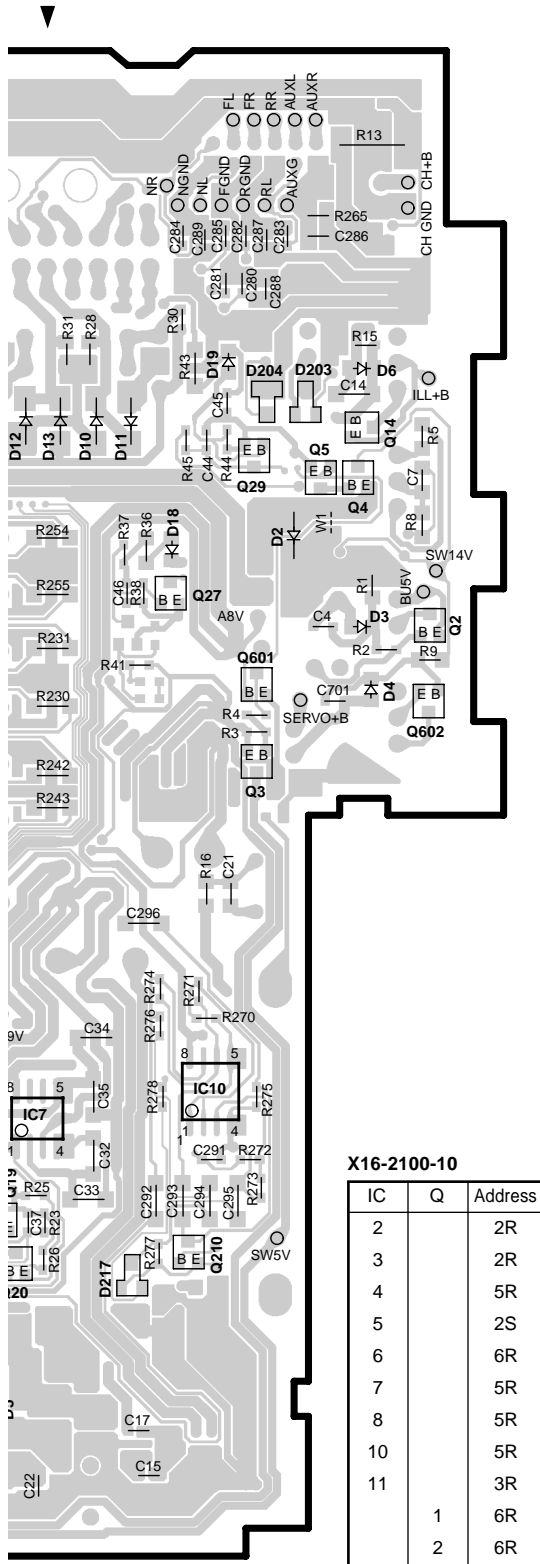

X16-2100-10

IC	Q	Address
2		2R
3		2R
4		5R
5		2S
6		6R
7		5R
8		5R
10		5R
11		3R
	1	6R
	2	6R
	3	6R
	4	2R
	5	6R
	6	6S
	7	6R
	8	2R
	10	6R

SUB-CIRCUIT UNIT
X16-2100-10 (J74-1477-12)

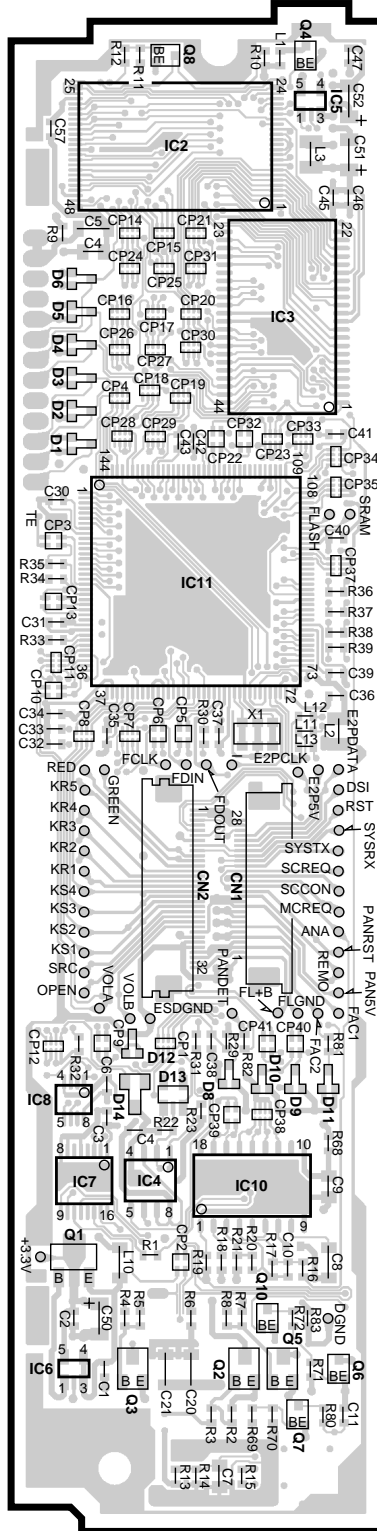

SWITCH UNIT
X16-2170-10 (J74-1482-12)

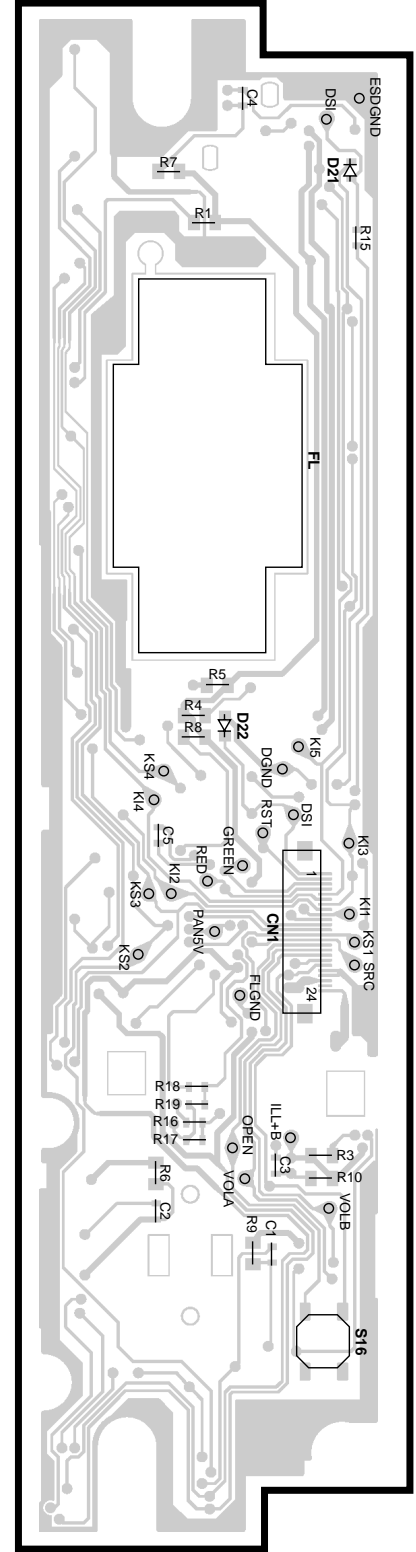

Refer to the schematic diagram for the values of resistors and capacitors.

PC BOARD (COMPONENT SIDE VIEW)

CD PLAYER UNIT
X32-5440-00 (J74-1487-12)

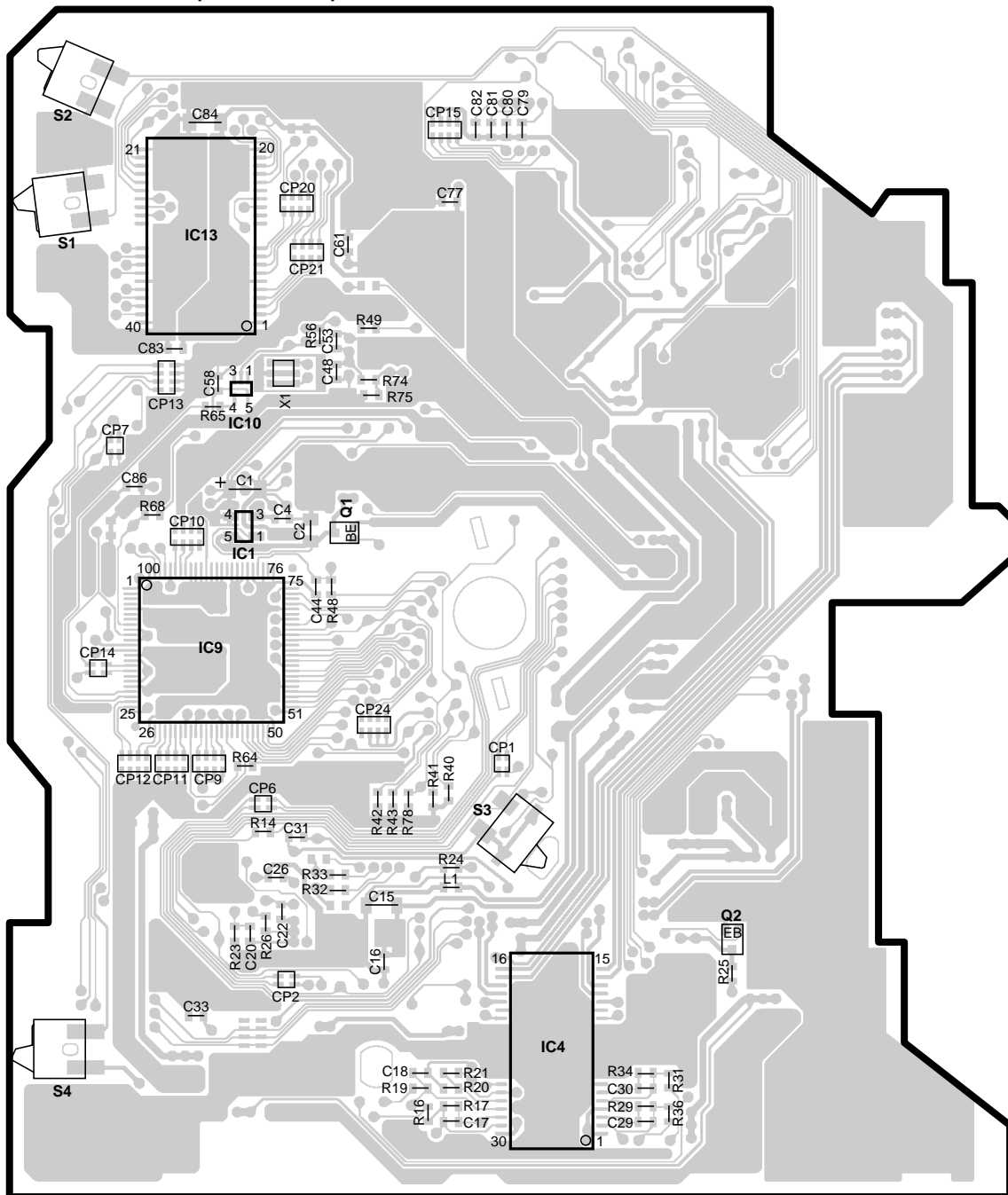

X32-5440-00

IC	Q	Address
1		3V
4		5W
9		4V
10		3V
13		2V
	1	3W
	2	5X

Refer to the schematic diagram for the values of resistors and capacitors.

PC BOARD (FOIL SIDE VIEW)

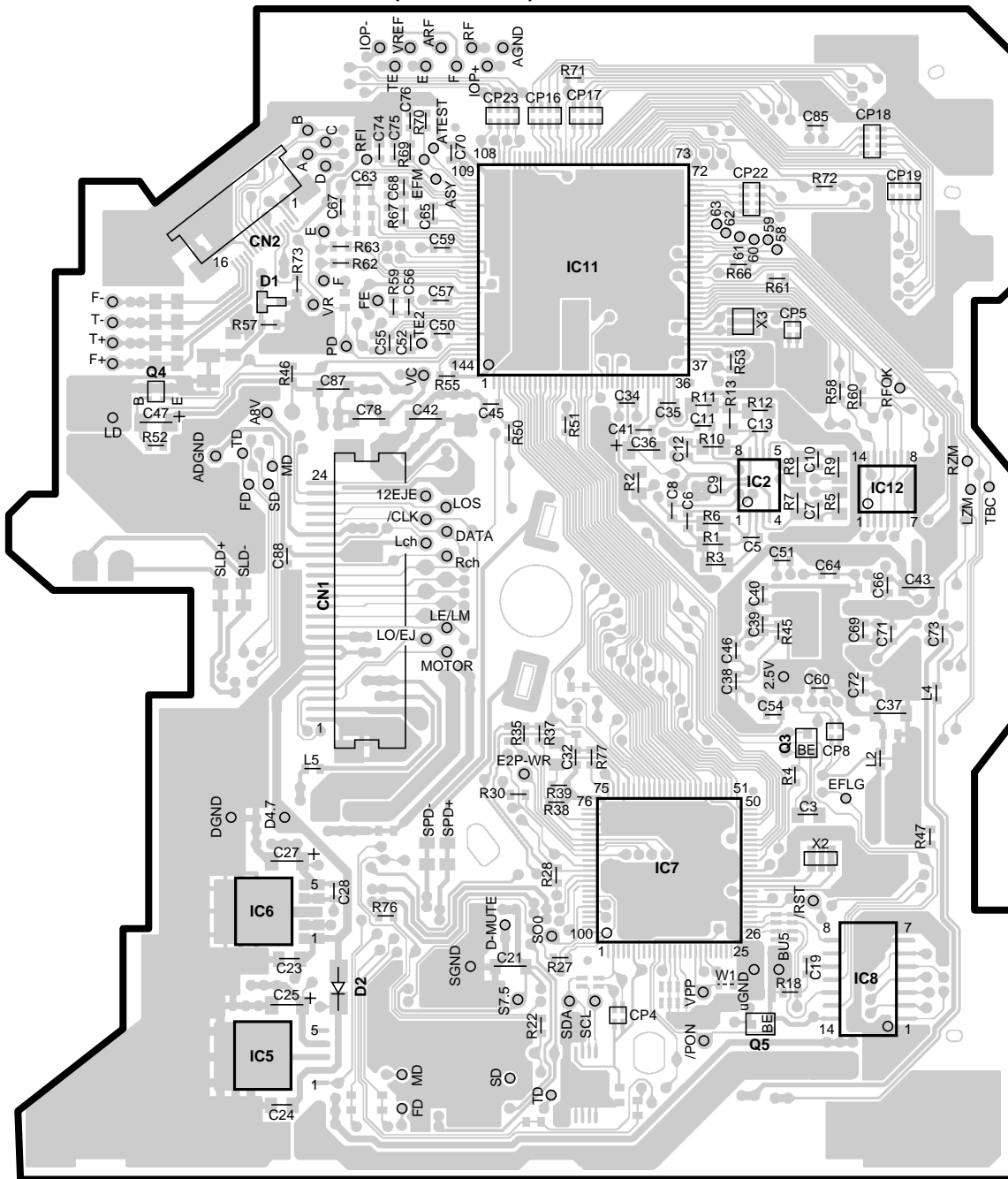
CD PLAYER UNIT
X32-5440-00 (J74-1487-12)

X32-5440-00

IC	Q	Address	IC	Q	Address
2		3AC	11		2AB
5		5AA	12		3AC
6		5AA	3		4AC
7		5AB	4		3Z
8		5AC	5		5AC

Refer to the schematic diagram for the values of resistors and capacitors.

KDC-9023R /PSW9524/X969

(X25-964X-XX)

MODEL NAME	UNIT No.	A	B	C	D	E	F	G	H	I	J	K	M	A1 (X86-373X-XX)
KDC-X969	0-10	YES	YES	YES	YES	NO	YES	NO	YES	YES	YES	YES	YES	0-11
KDC-X869	0-11	YES	YES	YES	YES	NO	YES	NO	YES	YES	YES	YES	YES	0-11
KDC-MP922	0-12	YES	YES	YES	NO	NO	YES	NO	YES	YES	YES	YES	YES	0-11
FX-9000	0-01	YES	NO	YES	YES	YES	YES	NO	NO	NO	YES	NO	YES	0-01
KDC-PSW9524	2-71	YES	YES	NO	YES	YES	YES	YES	YES	YES	YES	NO	NO	2-70
KDC-8024	2-72	NO	NO	NO	YES	YES	YES	NO	YES	YES	YES	NO	NO	2-70
KDC-9023R	0-21	YES	YES	NO	YES	YES	YES	YES	NO	YES	NO	YES	YES	2-70

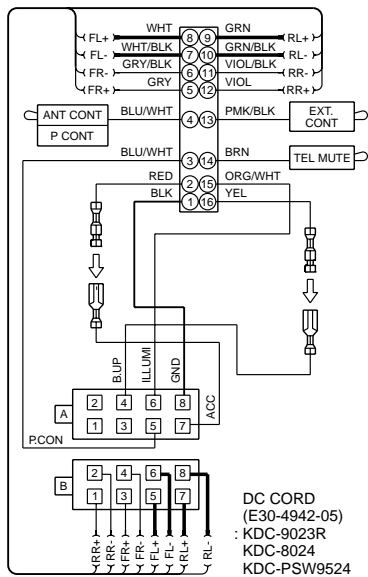
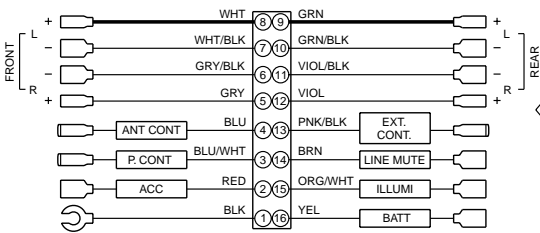
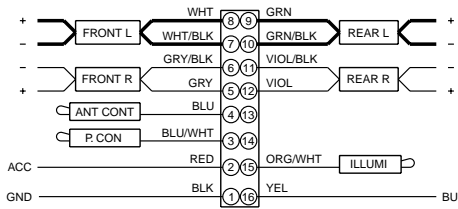
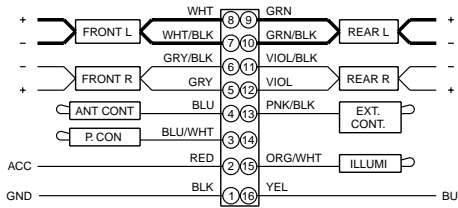

(X25-964X-XX)

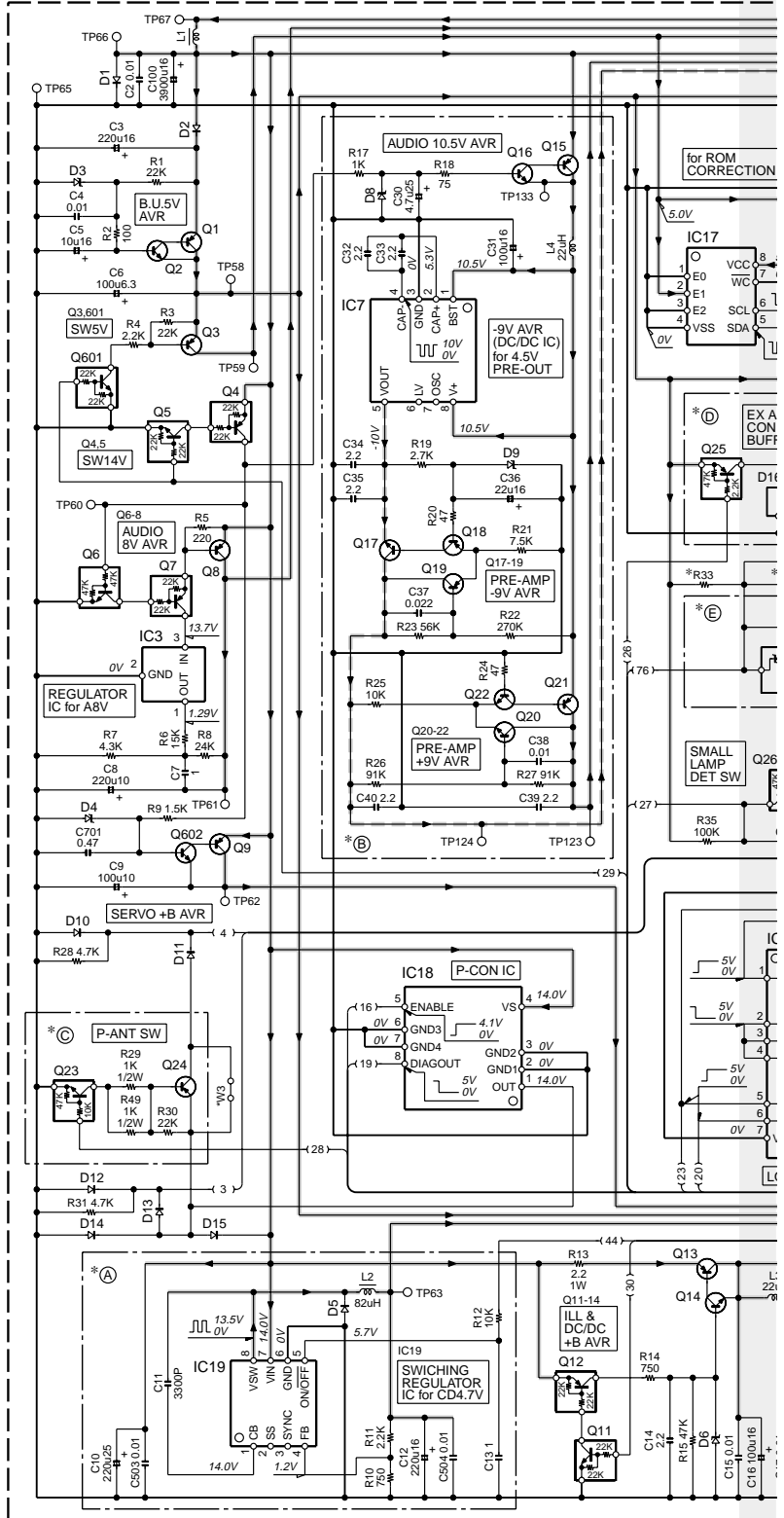

CAUTION : For continued safety, replace safety critical components only with manufacturer's recommended parts (refer to parts list).

⚠ Indicates safety critical components. To reduce the risk of electric shock, leakage-current or resistance measurements shall be carried out (exposed parts are acceptably insulated from the supply circuit) before the appliance is returned to the customer.

- DC voltages are as measured with a high impedance voltmeter. Values may vary slightly due to variations between individual instruments or/and units

KDC-9023R /PSW9524/X969

(X25-964X-XX)

MODEL NAME	UNIT No.	C203-205	C264,265,268,269,287,298	C501	C502	C505	D203,204	IC1 (70300386GCXXX)	R33	R34	R47	R48,184	R106	R107	R108	R109	R124-126	R148,149,154,155,521	R185	R222,223,234,235,246,247	R230,231,242,243,254,255	R526	W3
KDC-X969	0-10	YES	22u16	NO	YES	NO	YES	020	NO	100K	NO	YES	NO	NO	YES	YES	NO	NO	NO	2.2K	NO	YES	NO
KDC-X869	0-11	YES	22u16	NO	YES	NO	YES	020	NO	100K	NO	YES	YES	NO	NO	NO	NO	NO	NO	2.2K	NO	YES	NO
KDC-MP922	0-12	YES	22u16	NO	YES	NO	YES	020	NO	100K	NO	NO	YES	NO	NO	YES	NO	NO	NO	2.2K	NO	YES	NO
FX-9000	0-01	YES	10u16	NO	NO	YES	YES	020	100K	47K	YES	YES	YES	NO	NO	YES	NO	NO	YES	2.2K	NO	YES	NO
KDC-PSW9524	2-71	NO	22u16	YES	YES	NO	NO	020	47K	22K	YES	YES	NO	NO	YES	YES	NO	NO	YES	2.2K	NO	YES	YES
KDC-8024	2-72	NO	10u16	YES	YES	NO	NO	021	47K	22K	YES	YES	NO	NO	YES	YES	NO	NO	YES	2.2K	NO	YES	YES
KDC-9023R	0-21	YES	22u16	YES	YES	NO	YES	020	47K	22K	YES	YES	YES	NO	NO	YES	NO	NO	YES	2.2K	NO	YES	YES

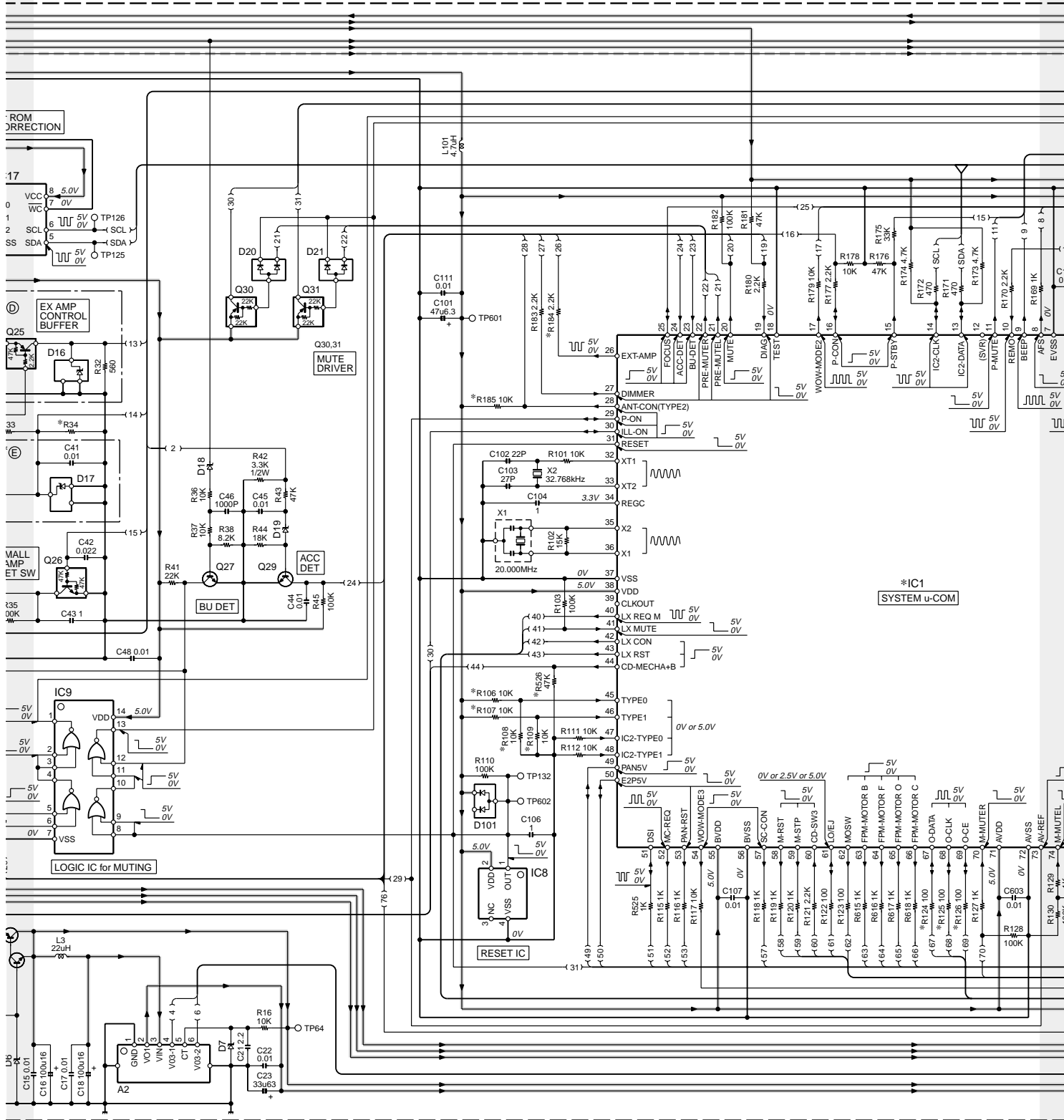

KDC-9023R /PSW9524/X969

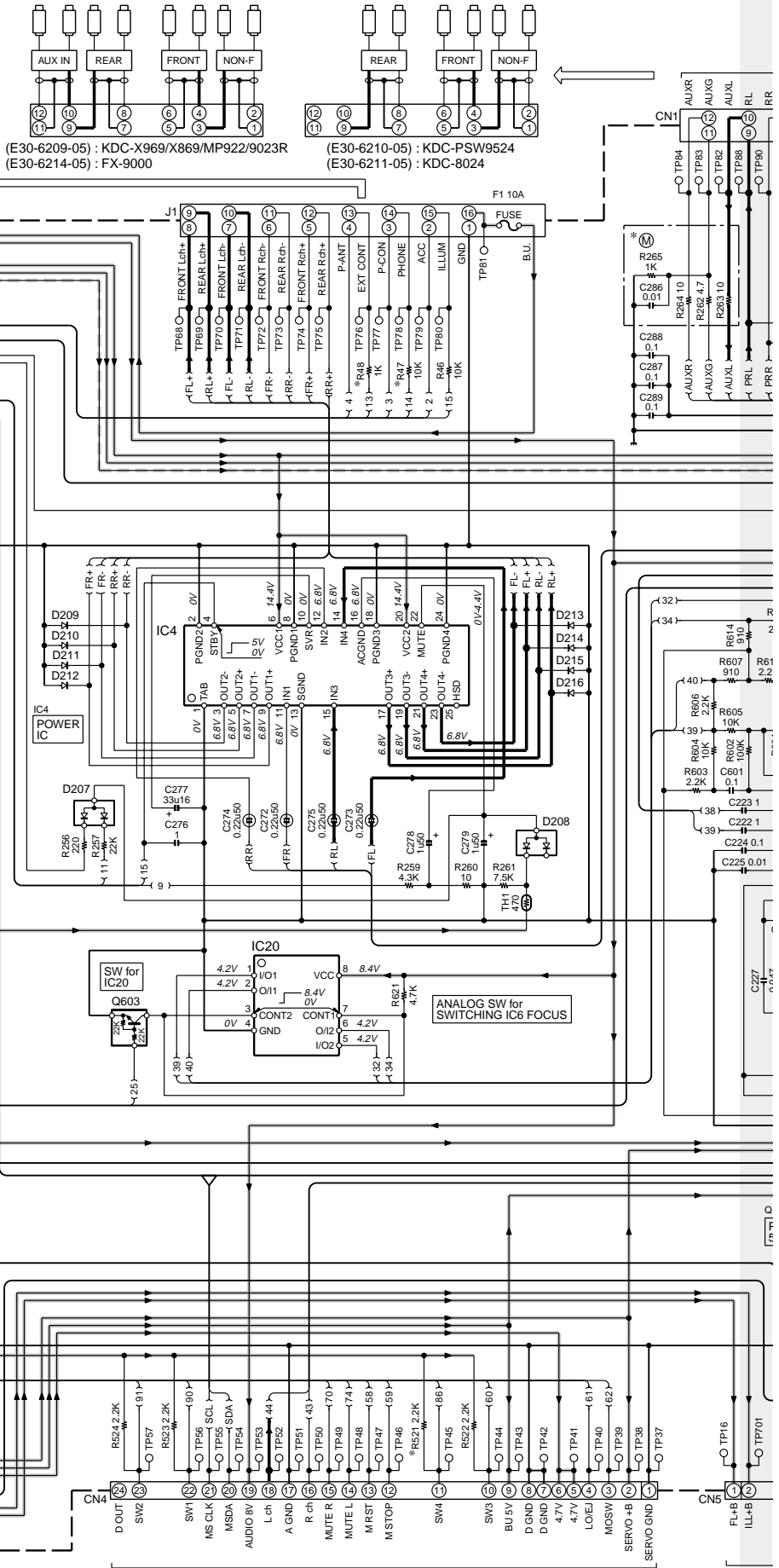

to CD MECHANISM

KDC-9023R /PSW9524/X969

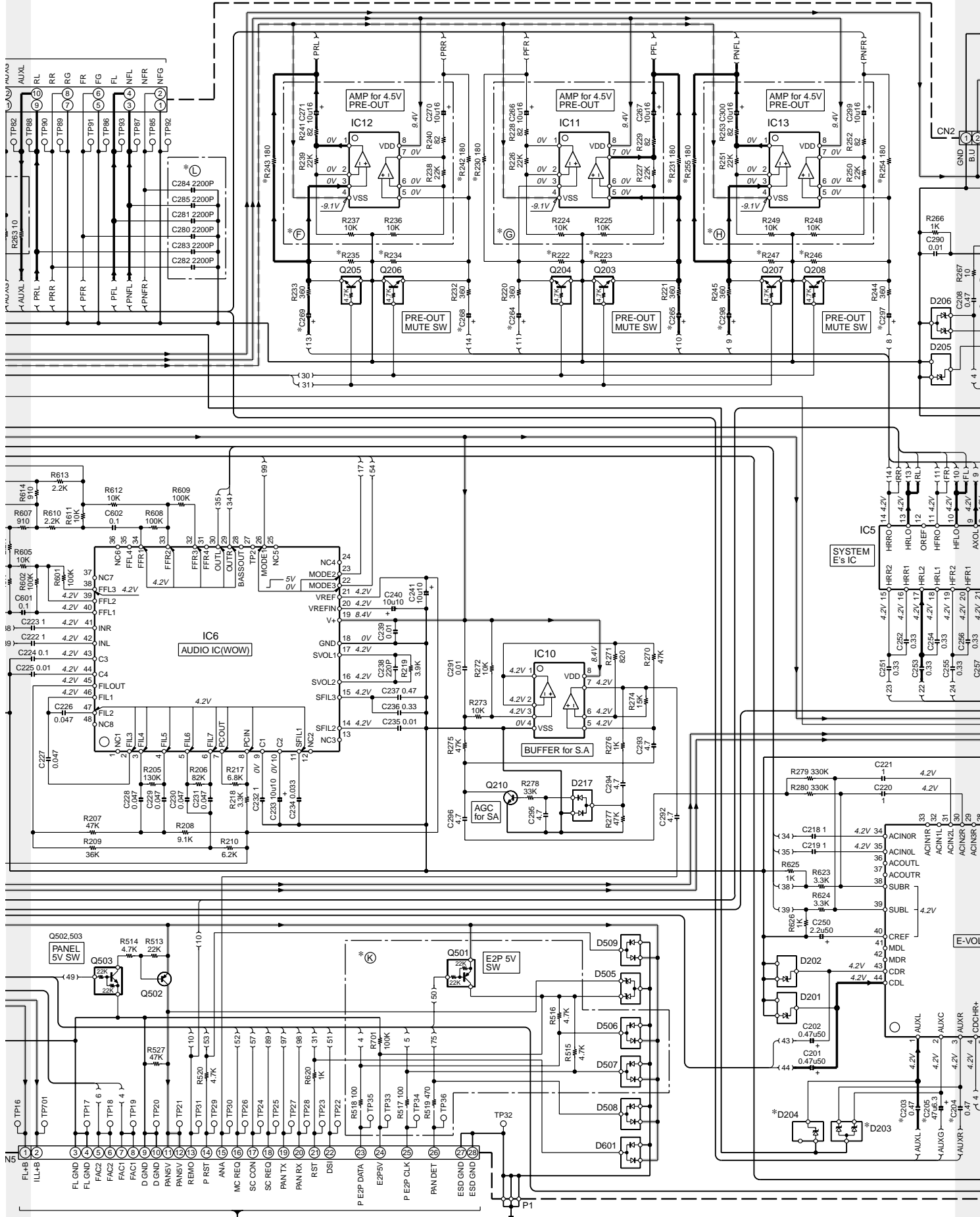

KDC-9023R /PSW9524/X969

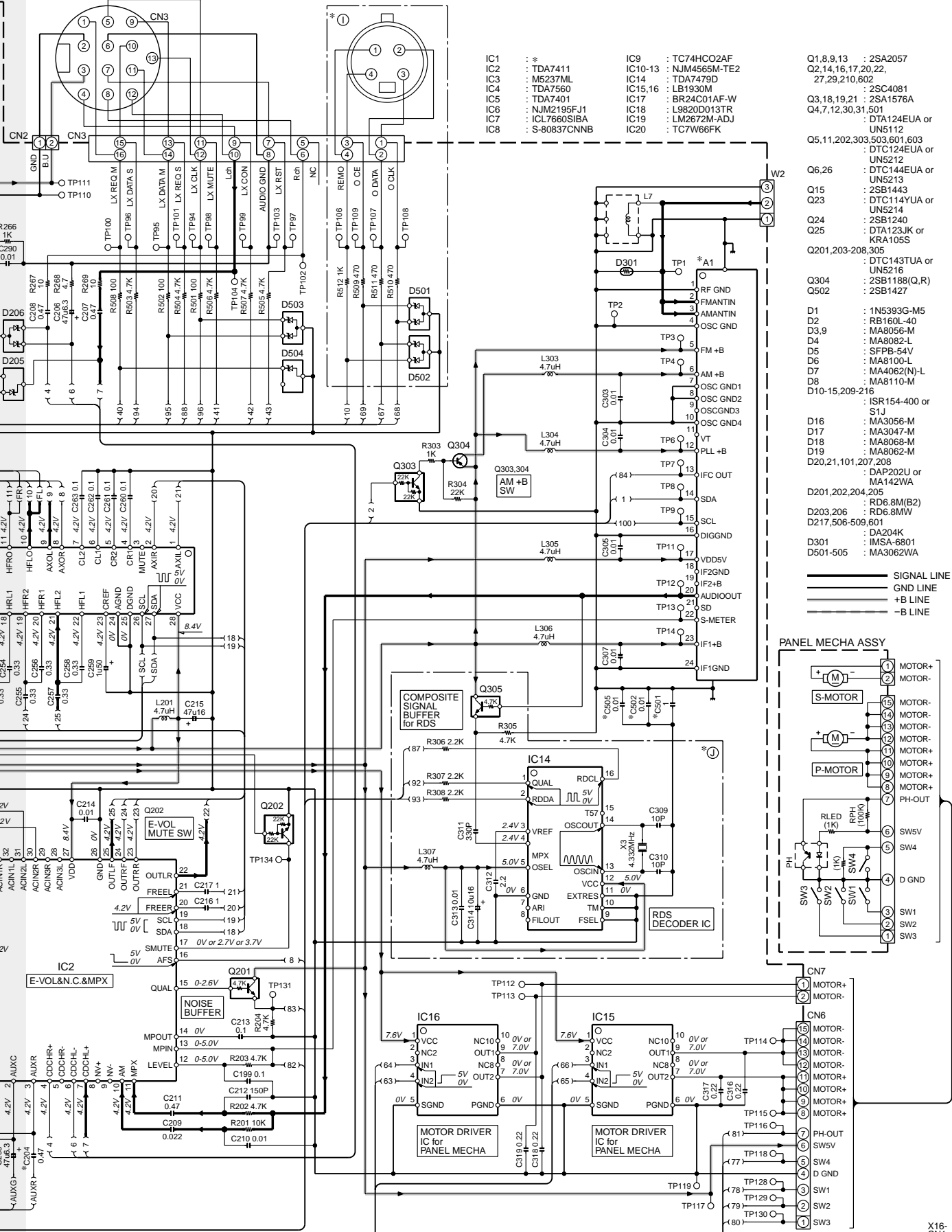

- Q1,8,9,13 : 2SA2057
- Q2,14,16,17,20,22, 27,29,210,602 : 2SC4081
- Q3,18,19,21 : 2SA1576A
- Q4,7,12,30,31,501 : DTA124EUA or UN5112
- Q5,11,202,303,503,601,603 : DTC124EUA or UN5212
- Q6,26 : DTC144EUA or UN5213
- Q15 : 2SB1443
- Q23 : DTC114YUA or UN5214
- Q24 : 2SB1240
- Q25 : DTA123JK or KRA105S
- Q201,203-208,305 : DTC143TUA or UN5216
- Q304 : 2SB1189(Q,R)
- Q502 : 2SB1427
- D1 : 1N5393G-M5
- D2 : RB160L-40
- D3,9 : MA8056-M
- D4 : MA8082-L
- D5 : SFPB-54V
- D6 : MA8100-L
- D7 : MA4062(N)-L
- D8 : MA8110-M
- D10-15,209-216 : ISR154-400 or S1J
- D16 : MA3056-M
- D17 : MA3047-M
- D18 : MA8068-M
- D19 : MA8062-M
- D20,21,101,207,208 : DAP202U or MA142WA
- D201,202,204,205 : RD6.8M(B2)
- D203,206 : RD6.8MW
- D217,506-509,601 : DA304K
- D301 : IMSA-6801
- D501-505 : MA3062WA

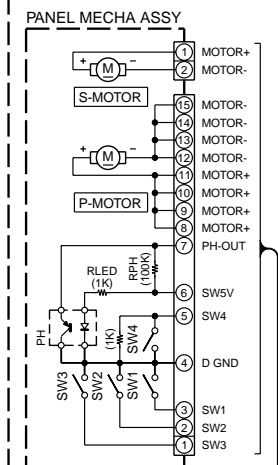
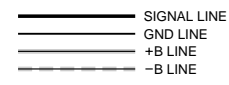

KDC-X969/PSW9524/9023R (1/3)

KDC-9023R /PSW9524/X969

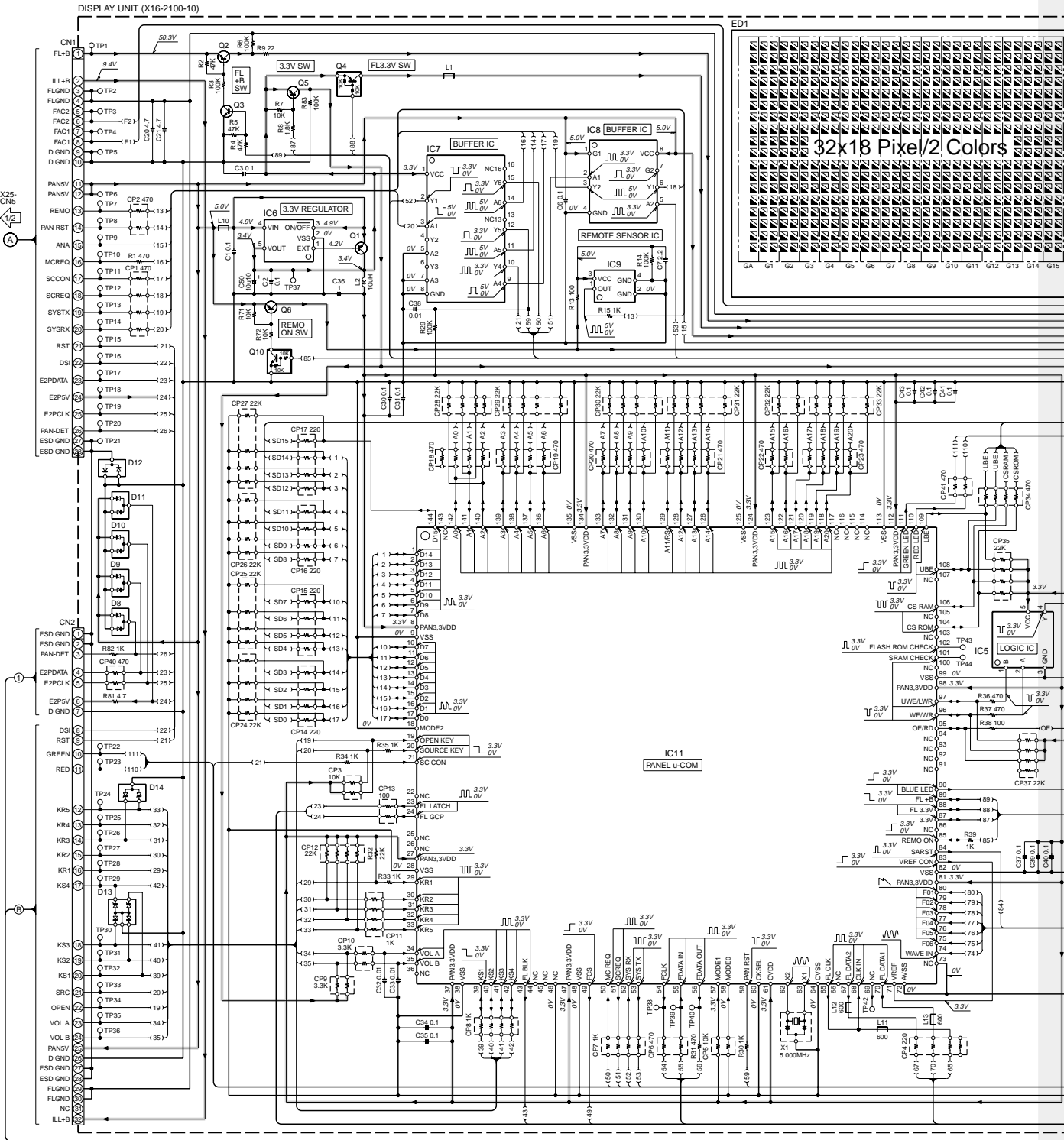

DTA123JK
 DTC114YUA
 DTC143TUA
 UN5111
 UN5211
 UN5213
 UN5214
 UN5216

2SA1163
 2SA1576A
 2SB1295
 2SC2713

2SB1188

2SB1443

2SC4081

DTA114EUA
 DTA124EUA
 DTA143EUA
 DTC114EUA
 DTC124EUA
 DTC144EUA

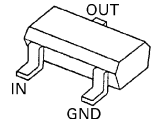
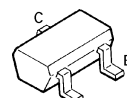
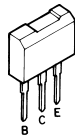
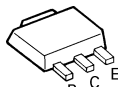

KDC-9023R /PSW9524/X969

144x36 Dot Matrix

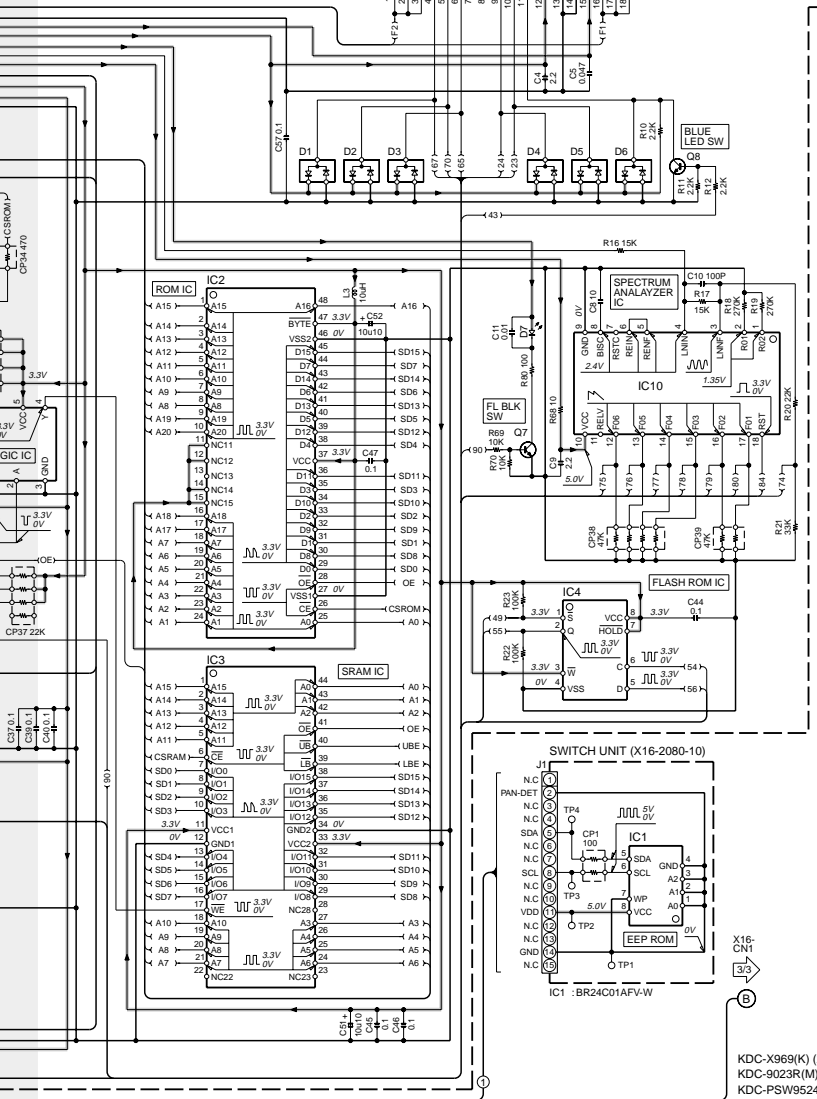
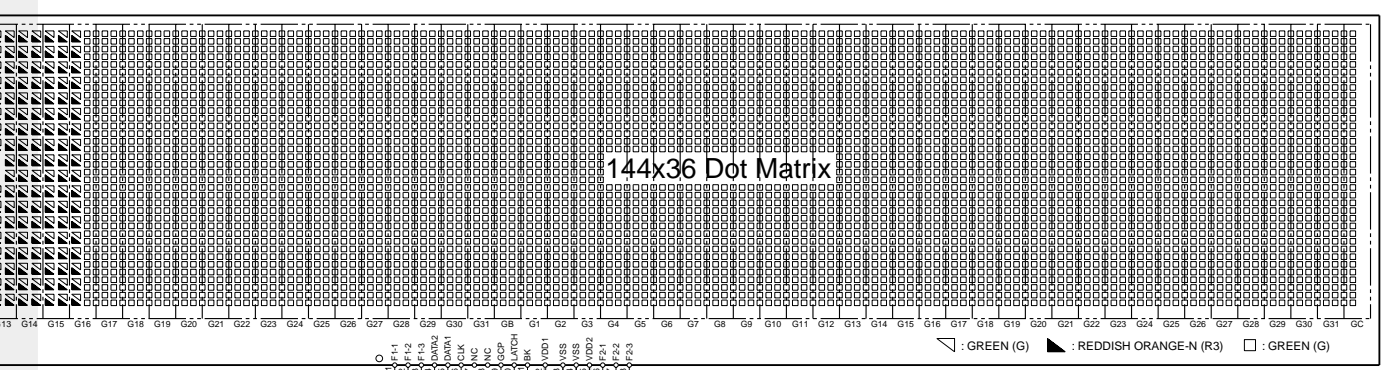

- IC2 : MX23L3213T112
 - IC3 : 61LV641615T1
 - IC4 : M25P20
 - IC5 : TC7SH08F
 - IC6 : S-816A34AMC-T2
 - IC7 : TC74HC4050AFT
 - IC8 : TC7WT126FU
 - IC9 : RS-171
 - IC10 : BA3830F
 - IC11 : 703107AGJ152
- Q1 : 2SB1188(O,R)
 - Q2 : 2SA1163
 - Q3 : 2SC2713
 - Q4 : DTA114EUA or UN5211
 - Q5 : 2SB1295
 - Q6 : 2SA1576A
 - Q7,8 : 2SC4081
 - Q10 : DTC114EUA or UN5211
- D1-6,8-12 : DA204U
 - D7 : B30-1564-05
 - D13 : FT25.8E
 - D14 : MA3062WA

CAUTION : For continued safety, replace safety critical components only with manufacturer's recommended parts (refer to parts list).
 ⚠ Indicates safety critical components. To reduce the risk of electric shock, leakage-current or resistance measurements shall be carried out (exposed parts are acceptably insulated from the supply circuit) before the appliance is returned to the customer.

- DC voltages are as measured with a high impedance voltmeter. Values may vary slightly due to variations between individual instruments or/and units

KDC-X969(K) (2/3)
 KDC-9023R(M) (2/3)
 KDC-PSW9524(E) (2/3)

NJM4565M-TE2

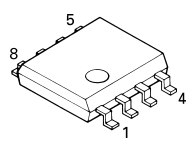

DAP202U
DA204K
DA204U
DTA114YUA

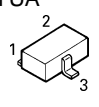

MA142WA
UN5212

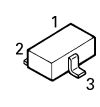

RD6.8M



TC74HCT7007AF
TC74HC02AF

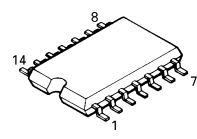

KDC-9023R /PSW9524/X969

SWITCH UNIT (X16-2170-10)

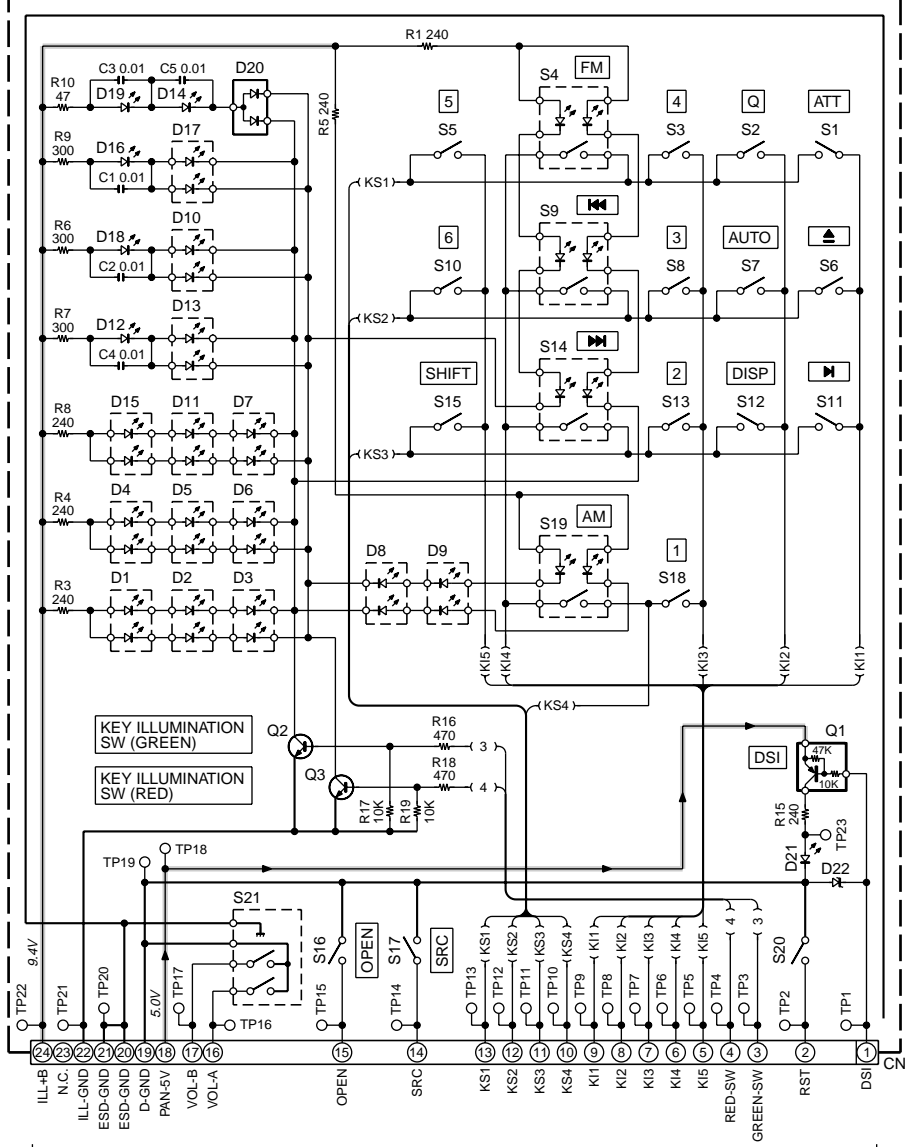

X16-
CN2
2/3
B

— GND LINE
— +B LINE

Q1 : DTA114YUA
Q2,3 : 2SC4081

D1-11,13,15,17 : B30-1605-05
D12,14,16,18,19 : B30-1564-05
D20 : DAP202U or MA142WA
D21 : B30-1566-05
D22 : MA8068-M

KDC-X969 (3/3)
KDC-9023R (3/3)
KDC-PSW9524 (3/3)

BA3830F

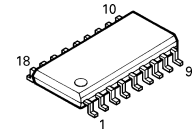

BR24C01AF-W

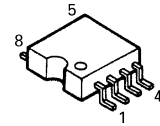

M5237ML

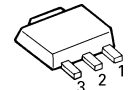

TC7SHU04FU

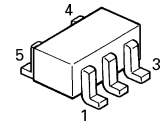

MCH6101

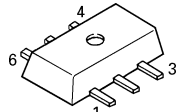

NJM4580V

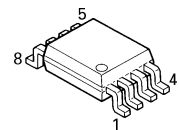

LB1930M

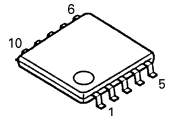
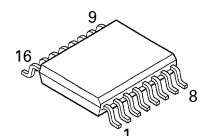
TC74HC4050AFT
TDA7479D

CAUTION : For continued safety, replace safety critical components only with manufacturer's recommended parts (refer to parts list).

⚠ Indicates safety critical components. To reduce the risk of electric shock, leakage-current or resistance measurements shall be carried out (exposed parts are acceptably insulated from the supply circuit) before the appliance is returned to the customer.

- DC voltages are as measured with a high impedance voltmeter. Values may vary slightly due to variations between individual instruments or/and units

KDC-9023R /PSW9524/X969

(X32-5440-00)

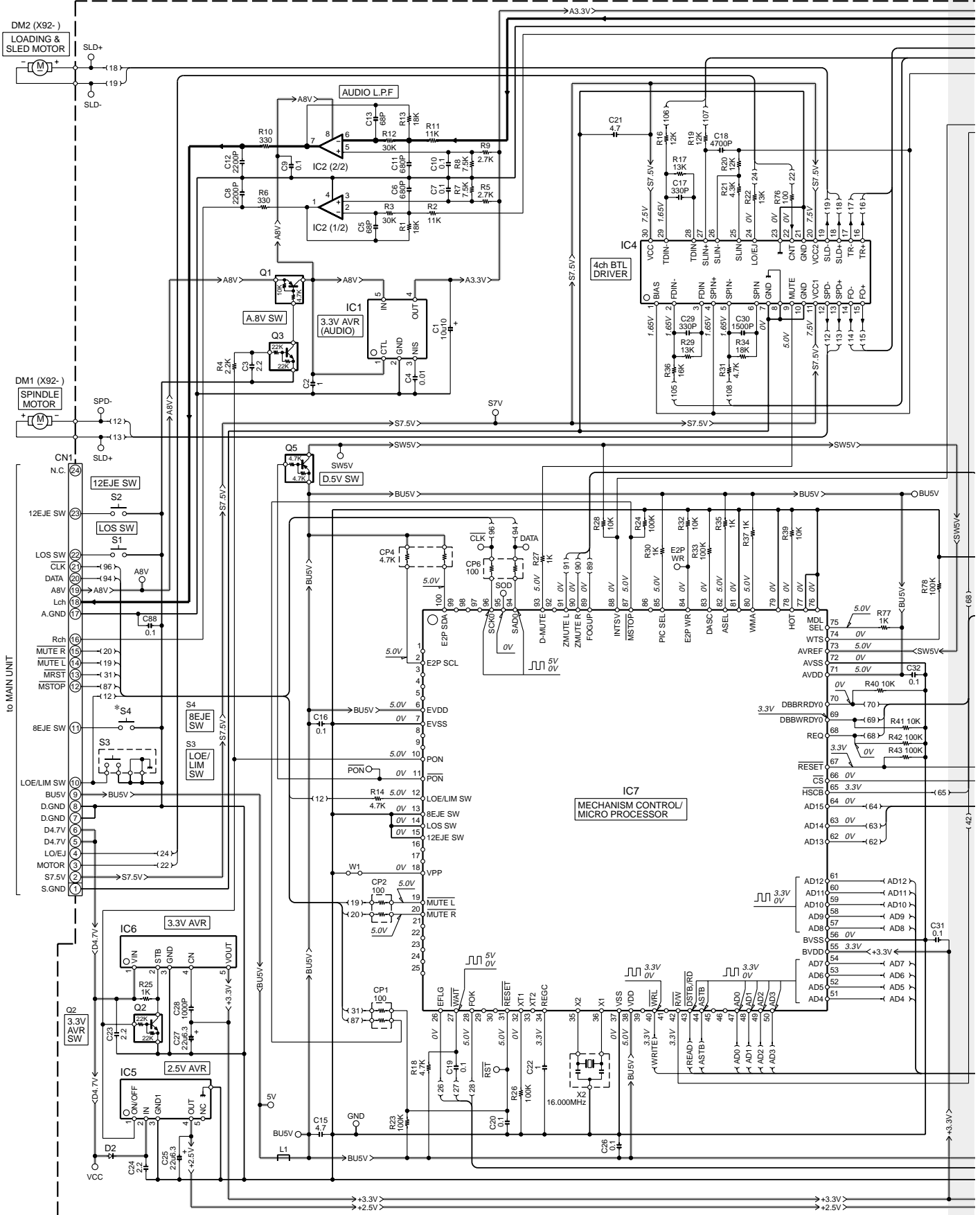

KDC-9023R /PSW9524/X969

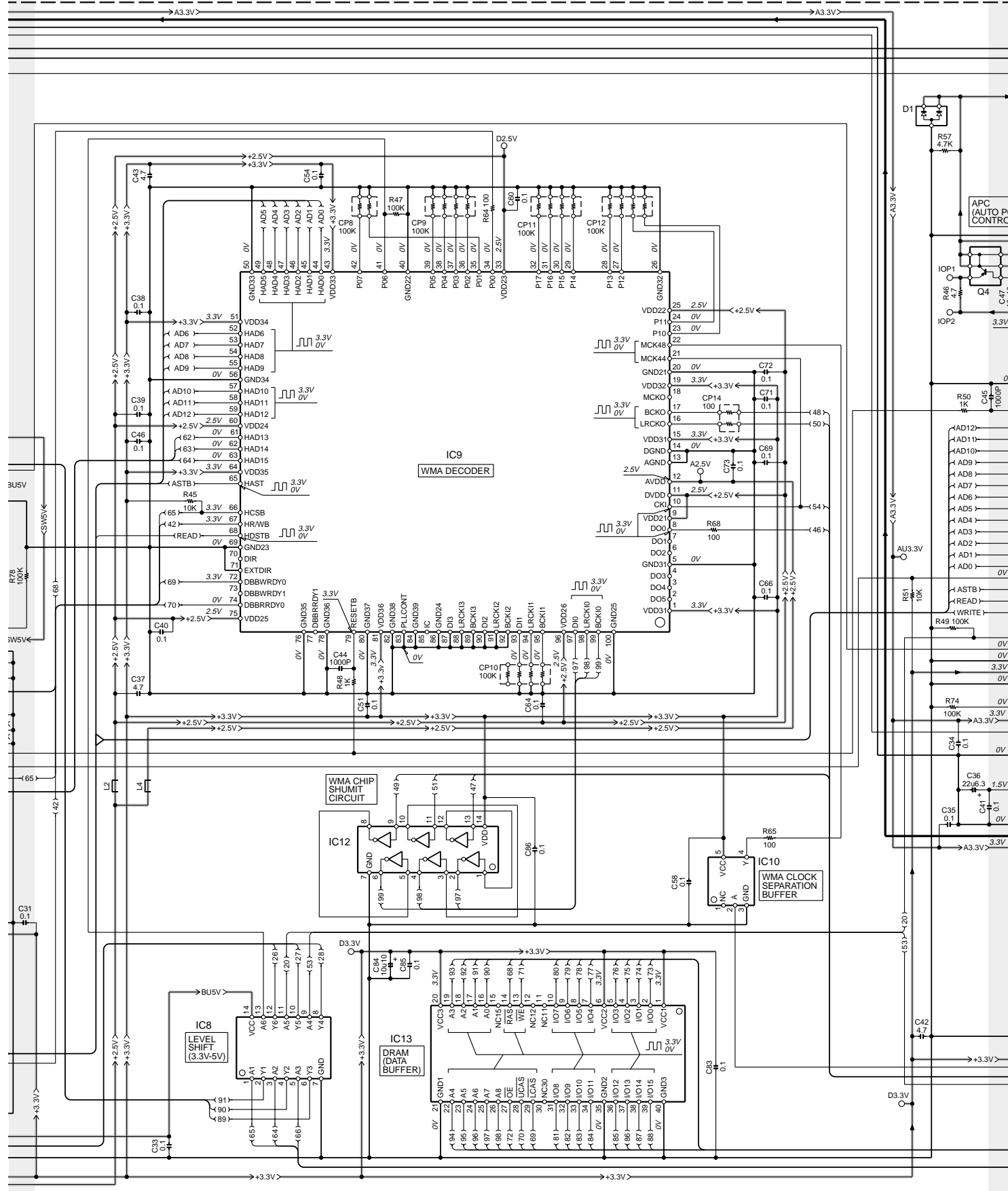

KDC-9023R /PSW9524/X969

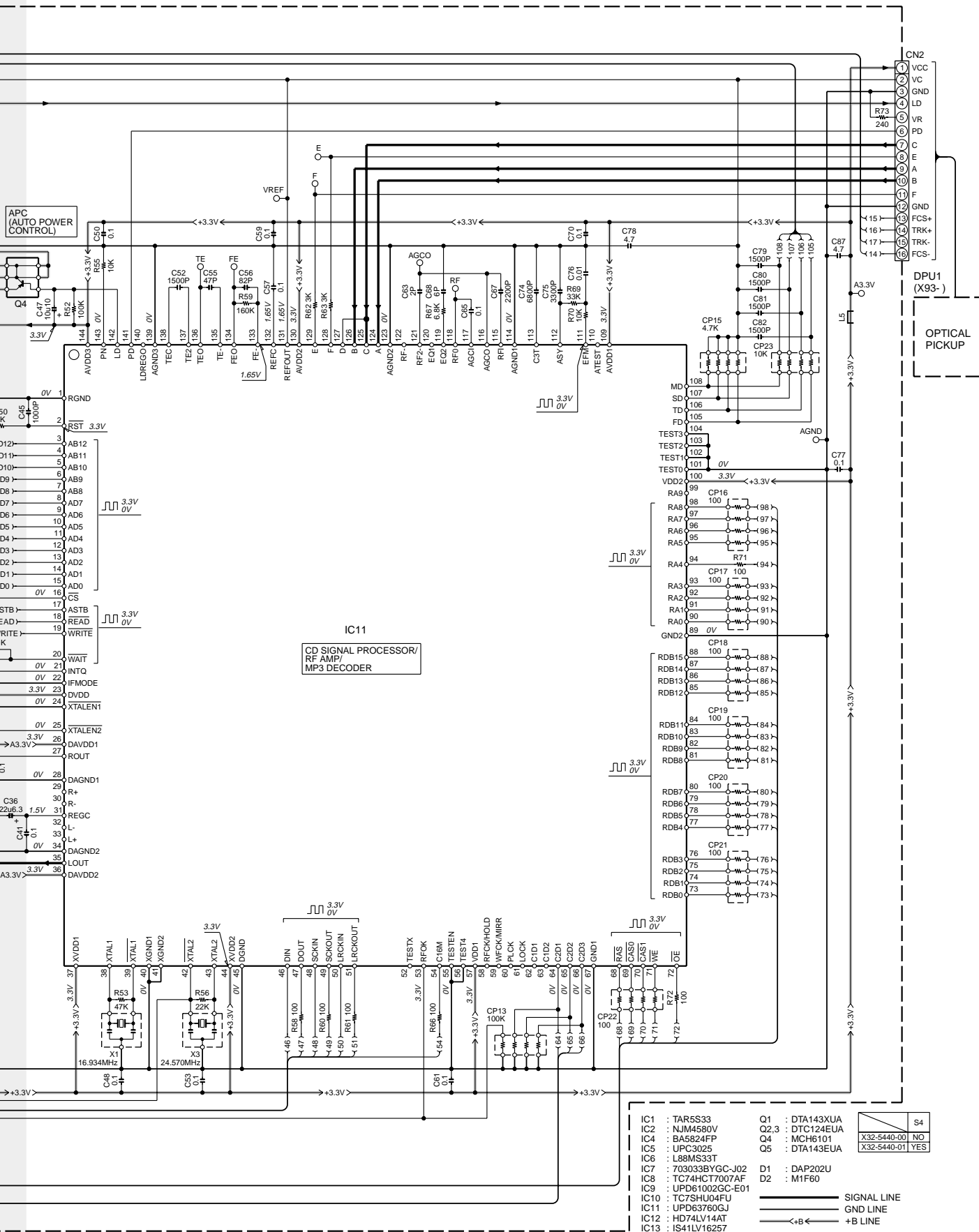

IC1 : TAR5S33	Q1 : DTA143XUA	S4 X32-5440-00 NO X32-5440-01 YES
IC2 : NJM4580V	Q2,3 : DTC124EUA	
IC4 : BA5824FP	Q4 : MCH6101	
IC5 : UPC3025	Q5 : DTA143EUA	
IC6 : L88MS33T		
IC7 : 703033BYGC-J02	D1 : DAP202U	
IC8 : TC74HC77007AF	D2 : M1F60	
IC9 : UPD61002GC-E01		
IC10 : TC7SHU04FU		
IC11 : UPD63760GJ		
IC12 : HD74LV14AT		
IC13 : IS41LV1625T		

CAUTION : For continued safety, replace safety critical components only with manufacturer's recommended parts (refer to parts list).
 ⚠ Indicates safety critical components. To reduce the risk of electric shock, leakage-current or resistance measurements shall be carried out (exposed parts are acceptably insulated from the supply circuit) before the appliance is returned to the customer.

EXPLODED VIEW (MECHANISM)

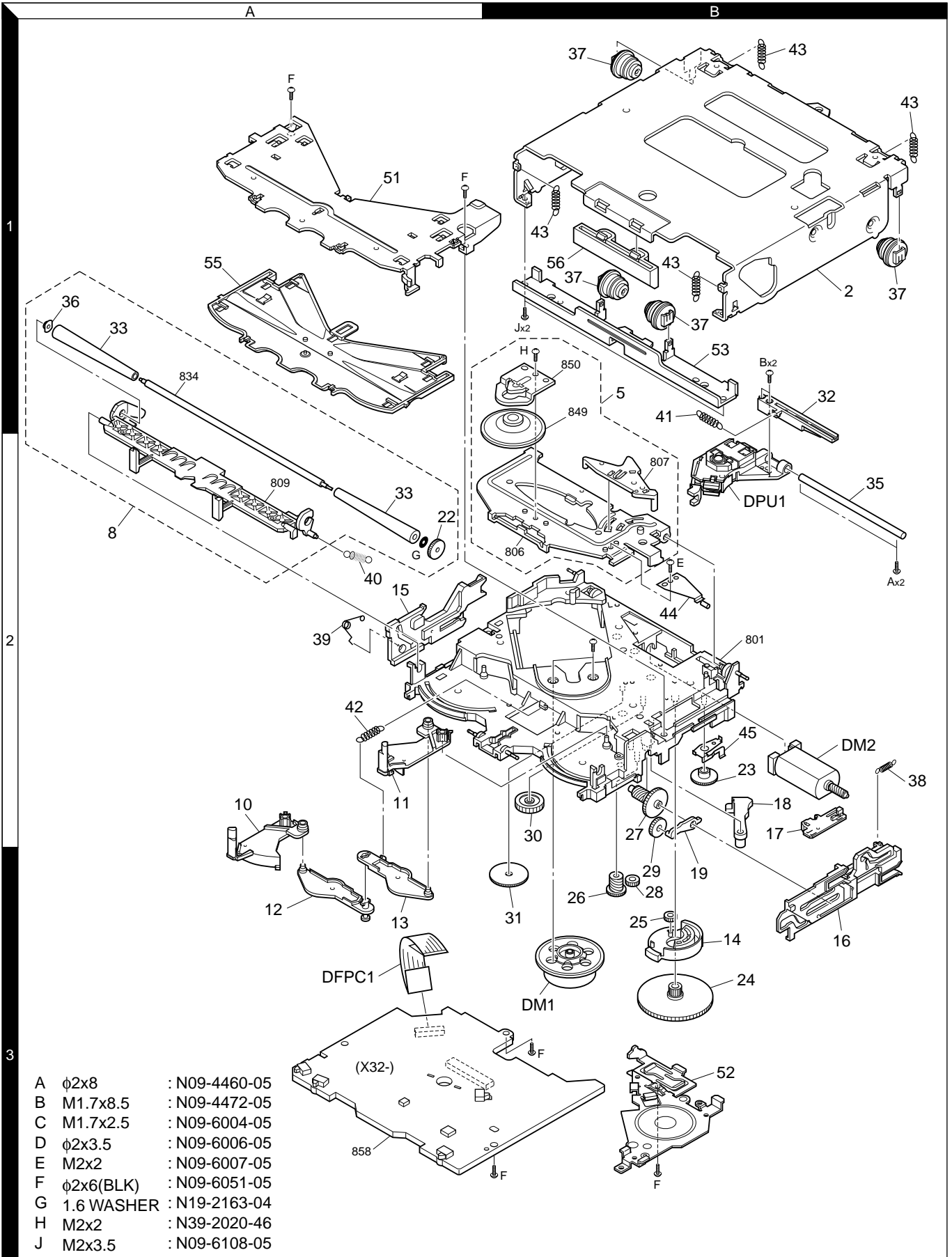

Parts with the exploded numbers larger than 700 are not supplied.

EXPLODED VIEW (UNIT)

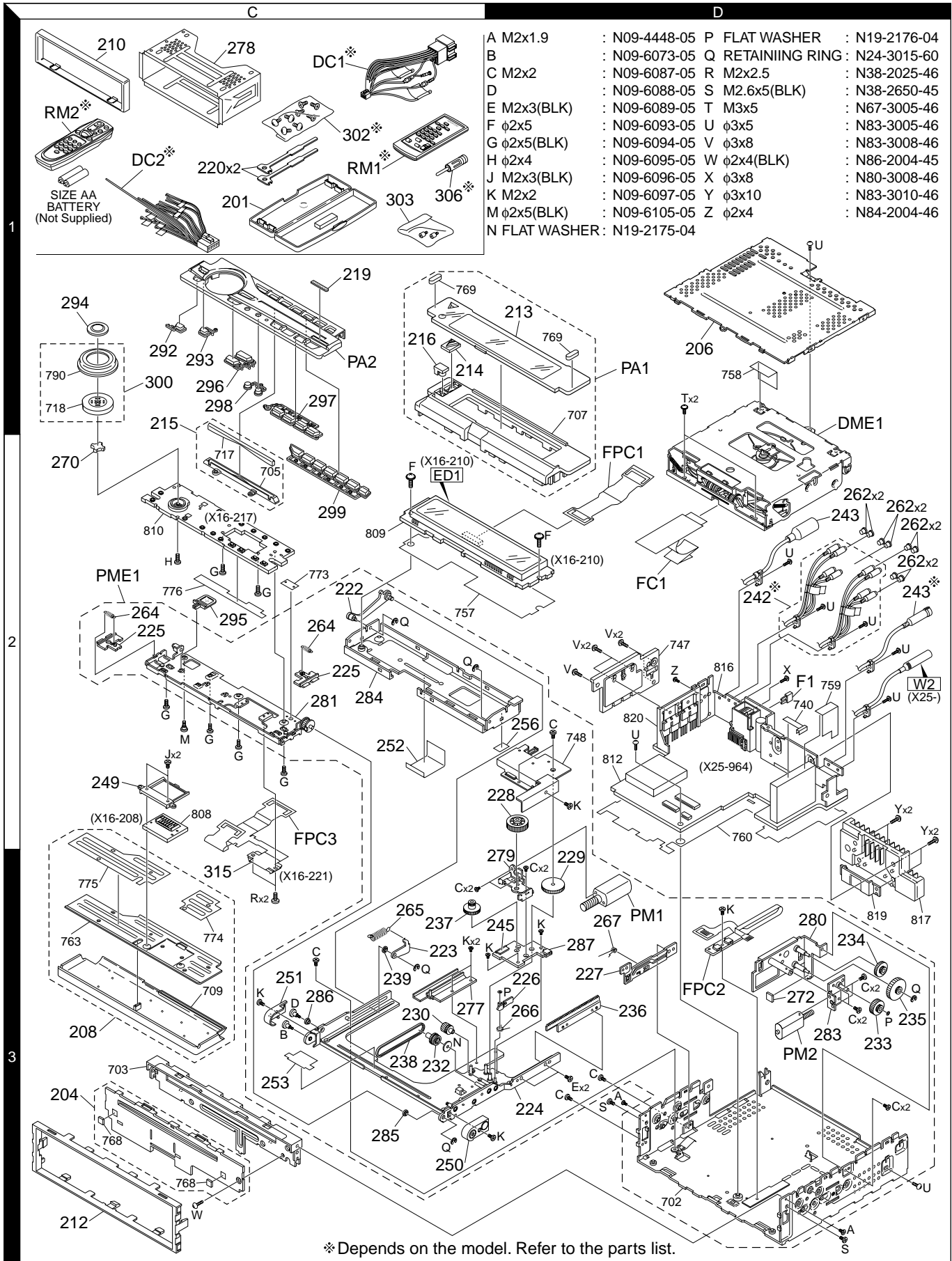

PARTS LIST

* New parts

Parts without **Parts No.** are not supplied.

Les articles non mentionnés dans le **Parts No.** ne sont pas fournis.

Teile ohne **Parts No.** werden nicht geliefert.

Ref. No.	A d d	N e w	Parts No.	Description	Desti- nation	Ref. No.	A d d	N e w	Parts No.	Description	Desti- nation
KDC-9023R/PSW9524/X969						242	2D	*	E30-6209-05	CORD WITH PINPLUG (3PR+1AUX)	KM1
201	1C	*	A02-2731-03	PLASTIC CABINET ASSY		242	2D	*	E30-6210-05	CORD WITH PINPLUG (3PR)	E1
204	3C	*	A22-2988-03	SUB PANEL ASSY		243	2D	*	E30-6216-05	CORD WITH DIN CONNECTOR (CH)	KM1
206	1D	*	A52-0831-02	TOP PLATE		243	2D	*	E30-6217-05	CORD WITH DIN CONNECTOR (CH+DIS)	E1
PA1	1D	*	A64-2975-01	PANEL ASSY	K	245	3D	*	E41-0351-05	FLAT CABLE CONNECTOR	
PA1	1D	*	A64-2982-01	PANEL ASSY	M1	Δ DC1	1C		E30-4942-05	DC CORD (ISO)	M1E1
PA1	1D	*	A64-2984-01	PANEL ASSY	E1	Δ DC2	1C		E30-6062-05	DC CORD	K
PA2	1C	*	A64-2993-02	PANEL ASSY	K	FC1	2D	*	E39-0565-05	FLAT CABLE (24P)	
PA2	1C	*	A64-3002-02	PANEL ASSY	M1E1	249	2C	*	F07-1121-03	COVER	
PME1	2C	*	A10-5029-11	CHASSIS ASSY		250	3C	*	F07-1122-03	COVER	
RM1	1C		A70-2026-05	REMOTE CONTROLLER ASSY (RC-420)	M1E1	251	3C	*	F07-1123-03	COVER	
RM2	1C		A70-2040-05	REMOTE CONTROLLER ASSY (RC-505)	K	252	2C	*	F09-1794-04	SHEET	
-			B46-0100-50	WARRANTY CARD		253	3C	*	F09-1798-04	SHEET	
-			B46-0606-04	ID CARD	K	256	2D	*	F09-1842-04	SHEET	
-			B46-0612-14	ID CARD	M1E1	262	2D		F29-0049-05	INSULATING COVER	
-		*	B46-0648-13	USER CARD	K	Δ F1	2D		F52-0006-05	FUSE (MINI BLADE TYPE) 10A	
-		*	B46-0653-03	USER CARD	K	264	2C	*	G01-3162-04	EXTENSION SPRING	
-		*	B64-2458-00	INSTRUCTION MANUAL (ENGLISH)	K	265	3C	*	G01-3188-04	EXTENSION SPRING	
-		*	B64-2459-00	INSTRUCTION MANUAL (FRE.SPA.)	K	266	3C	*	G01-3189-04	TORSION COIL SPRING	
-		*	B64-2462-00	INSTRUCTION MANUAL (ENG.T-CHI.)	M1	267	3D	*	G01-3199-04	TORSION COIL SPRING	
-		*	B64-2464-00	INSTRUCTION MANUAL (ENGLISH)	E1	270	2C	*	G11-3539-04	CUSHION (VOL)	
-		*	B64-2465-00	INSTRUCTION MANUAL (FRE.GER.)	E1	272	3D	*	G11-3559-04	CUSHION	
-		*	B64-2466-00	INSTRUCTION MANUAL (DUT.ITA.)	E1	-		*	H10-4854-12	POLYSTYRENE FOAMED FIXTURE	
-		*	B64-2467-00	INSTRUCTION MANUAL (SPA.POR.)	E1	-		*	H21-1151-04	PROTECTION SHEET	
208	3C	*	B03-5016-03	DRESSING PLATE ASSY		-		*	H25-0329-04	PROTECTION BAG (280X450X0.03)	KM1
210	1C	*	B07-3079-01	ESCUTCHEON		-		*	H25-0337-04	PROTECTION BAG (180X300X0.03)	
212	3C	*	B07-3080-02	ESCUTCHEON		-		*	H25-1111-04	PROTECTION BAG (280X450X0.03)	E1
213	1D	*	B10-4382-01	FRONT GLASS	K	-		*	H54-2715-03	ITEM CARTON CASE	K
213	1D	*	B10-4389-01	FRONT GLASS	M1	-		*	H54-2722-03	ITEM CARTON CASE	M1
213	1D	*	B10-4391-01	FRONT GLASS	E1	-		*	H54-2724-03	ITEM CARTON CASE	E1
214	1C	*	B12-1221-04	INDICATOR		277	3C	*	J19-5220-03	HOLDER	
215	1C	*	B12-1222-03	INDICATOR ASSY		278	1C	*	J21-9823-03	MOUNTING HARDWARE ASSY	
216	1C	*	B19-2201-04	LIGHTING BOARD		279	3D	*	J21-9951-03	MOUNTING HARDWARE ASSY	
219	1C	*	B43-1505-04	KENWOOD BADGE		280	3D	*	J21-9954-02	MOUNTING HARDWARE ASSY	
220	1C		D10-4674-04	LEVER		281	2C	*	J21-9956-12	MOUNTING HARDWARE ASSY	
222	2C	*	D10-4716-04	ARM ASSY		283	3D	*	J21-9997-03	MOUNTING HARDWARE ASSY	
223	3C	*	D10-4718-04	ARM ASSY		284	2C	*	J21-9999-02	MOUNTING HARDWARE ASSY	
224	3D	*	D10-4721-11	SLIDER ASSY		285	3C	*	J31-1055-04	COLLAR	
225	2C	*	D10-4749-03	LEVER		286	3C	*	J31-1056-04	COLLAR	
226	3D	*	D10-4750-04	LEVER		287	3D	*	J74-1444-04	RIGID PRINTED WIRING BOARD	
227	3D	*	D12-0637-03	CAM		FPC1	2D	*	J84-0153-05	FLEXIBLE PRINTED WIRING BOARD	
228	2D	*	D13-2270-04	GEAR		FPC2	3D	*	J84-0156-04	FLEXIBLE PRINTED WIRING BOARD	
229	3D	*	D13-2272-04	GEAR		292	1C	*	K24-4004-04	KNOB (PLAY)	
230	3C	*	D13-2273-14	GEAR		293	1C	*	K24-4005-04	KNOB (EJECT)	
232	3C	*	D13-2274-14	GEAR		294	1C	*	K24-4006-04	KNOB (ATT)	
233	3D	*	D13-2276-04	GEAR		295	2C	*	K24-4007-04	KNOB (OPEN)	
234	3D	*	D13-2277-04	GEAR		296	1C	*	K25-1527-03	KNOB (SRC,Q)	
235	3D	*	D13-2278-04	GEAR		297	1C	*	K25-1529-03	KNOB (AM/FM)	
236	3D	*	D13-2289-03	RACK (GEAR)		298	1C	*	K25-1530-04	KNOB (SCRL)	
237	3C	*	D13-2290-04	GEAR ASSY		299	2C	*	K25-1532-03	KNOB (1-6)	
238	3C	*	D16-0617-05	BELT		300	1C	*	K29-7031-03	KNOB ASSY (VOL)	
239	3C	*	D23-0958-04	RETAINER		302	1C		N99-1723-05	SCREW SET	KM1

E : Europe K : North America
M : Other Areas W : Without Europe

K : KDC-X969
M1 : KDC-9023R
E1 : KDC-PSW9524

Δ Indicates safety critical components.

PARTS LIST

* New parts

Parts without **Parts No.** are not supplied.

Les articles non mentionnés dans le **Parts No.** ne sont pas fournis.

Teile ohne **Parts No.** werden nicht geliefert.

KDC-9023R/PSW9524/X969

Ref. No.	A d d	N e w	Parts No.	Description	Desti- nation
303	1C	*	N99-1734-05	SCREW SET	
A	3D		N09-4448-05	MACHINE SCREW	
B	3C	*	N09-6073-05	STEPPED SCREW	
C	3D	*	N09-6087-05	MACHINE SCREW	
D	3C	*	N09-6088-05	STEPPED SCREW	
E	3D	*	N09-6089-05	MACHINE SCREW	
F	2C	*	N09-6093-05	TAPTITE SCREW	
G	2C	*	N09-6094-05	MACHINE SCREW	
H	2C	*	N09-6095-05	MACHINE SCREW	
J	2C	*	N09-6096-05	MACHINE SCREW	
K	3C	*	N09-6097-05	MACHINE SCREW	
M	2C	*	N09-6105-05	STEPPED SCREW	
N	2C	*	N19-2175-04	FLAT WASHER	
P	3D	*	N19-2176-04	FLAT WASHER	
Q	2C		N24-3015-60	E TYPE RETAINING RING	
R	3C		N38-2025-46	PAN HEAD MACHIN SCREW	
S	3D	*	N38-2650-45	PAN HEAD MACHIN SCREW	
T	2D		N67-3005-46	PAN HEAD SEMS SCREW	
U	2D		N83-3005-46	PAN HEAD TAPTITE SCREW	
V	2D		N83-3008-46	PAN HEAD TAPTITE SCREW	
W	3C		N86-2004-45	BINDING HEAD TAPTITE SCREW	
RLED			RK73GB2A102J	CHIP R 1.0K J 1/10W	
RPH			RK73GB2A104J	CHIP R 100K J 1/10W	
SW1			S68-0871-05	PUSH SWITCH (PANEL MECHA)	
SW2-3			S68-0863-05	PUSH SWITCH (PANEL MECHA)	
SW4			S68-0864-05	PUSH SWITCH (PANEL MECHA)	
306	1C		T90-0552-05	ANTENNA ADAPTOR	M1E1
PH			T95-0212-05	OPTO ISOLATOR (PANEL MECHA)	
PM1	3D	*	T42-1076-14	MOTOR ASSY	
PM2	3D	*	T42-1077-04	MOTOR ASSY	
DME1	2D	*	X92-4710-01	CD MECHANISM ASSY	
SUB-CIRCUIT UNIT (X16-2080-10)					
J1			E59-0833-15	RECTANGULAR PLUG	
CP1			R90-1019-05	MULTI-COMP 100 X2	
IC1		*	BR24C01AFV-W	MEMORY IC	
SUB-CIRCUIT UNIT (X16-2100-10)					
D7			B30-1564-05	LED (1608,BLUE)	
C1-3			CK73GB1C104K	CHIP C 0.10UF K	
C1-3			CK73GB1H104K	CHIP C 0.10UF K	
C4			CK73FB1A225K	CHIP C 2.2UF K	
C5			C93-1217-05	CHIP C 0.047UF K	
C6			CK73GB1C104K	CHIP C 0.10UF K	
C6			CK73GB1H104K	CHIP C 0.10UF K	
C7			CK73FB1A225K	CHIP C 2.2UF K	
C8			CK73EB0J106K	CHIP C 10UF K	
C9			CK73FB1A225K	CHIP C 2.2UF K	
C10			CC73GCH1H101J	CHIP C 100PF J	
C11			CK73GB1H103K	CHIP C 0.010UF K	
C20,21			CK73EB1A475K	CHIP C 4.7UF K	
C30,31			CK73GB1C104K	CHIP C 0.10UF K	

Ref. No.	A d d	N e w	Parts No.	Description	Desti- nation
C30,31			CK73GB1H104K	CHIP C 0.10UF K	
C32,33			CK73GB1H103K	CHIP C 0.010UF K	
C34,35			CK73GB1C104K	CHIP C 0.10UF K	
C34,35			CK73GB1H104K	CHIP C 0.10UF K	
C36			CK73GB0J105K	CHIP C 1.0UF K	
C37			CK73GB1C104K	CHIP C 0.10UF K	
C37			CK73GB1H104K	CHIP C 0.10UF K	
C38			CK73GB1H103K	CHIP C 0.010UF K	
C39-47			CK73GB1C104K	CHIP C 0.10UF K	
C39-47			CK73GB1H104K	CHIP C 0.10UF K	
C50-52			C92-0628-05	CHIP-TAN 10UF 10WV	
C57			CK73GB1C104K	CHIP C 0.10UF K	
C57			CK73GB1H104K	CHIP C 0.10UF K	
CN1			E40-9364-05	FLAT CABLE CONNECTOR	
CN2			E41-0166-05	FLAT CABLE CONNECTOR	
-		*	H30-0573-04	ADHESIVE DOUBLE-COATED TAPE	
L1			L92-0332-05	CHIP FERRITE	
L2,3			L40-1005-34	SMALL FIXED INDUCTOR	
L2,3			L40-1005-68	SMALL FIXED INDUCTOR	
L10			L92-0315-05	CHIP FERRITE	
L11-13			L92-0332-05	CHIP FERRITE	
X1			L78-0868-05	RESONATOR (5.00MHZ)	
CP1			R90-1502-05	MULTI-COMP 470 X4	
CP2			R90-1022-05	MULTI-COMP 470 X2	
CP3			R90-0726-05	MULTI-COMP 10K X2	
CP4			R90-1524-05	MULTI-COMP 220 X4	
CP5			R90-0726-05	MULTI-COMP 10K X2	
CP6			R90-1022-05	MULTI-COMP 470 X2	
CP7,8			R90-1094-05	MULTI-COMP 1K X4	
CP9,10			R90-1021-05	MULTI-COMP 3.3K X2	
CP11			R90-1094-05	MULTI-COMP 1K X4	
CP12			R90-1085-05	MULTI-COMP 22K X4	
CP13			R90-1019-05	MULTI-COMP 100 X2	
CP14-17			R90-1524-05	MULTI-COMP 220 X4	
CP18-21			R90-1502-05	MULTI-COMP 470 X4	
CP22			R90-1022-05	MULTI-COMP 470 X2	
CP23			R90-1502-05	MULTI-COMP 470 X4	
CP24-31			R90-1085-05	MULTI-COMP 22K X4	
CP32			R90-1020-05	MULTI-COMP 22K X2	
CP33			R90-1085-05	MULTI-COMP 22K X4	
CP34			R90-1502-05	MULTI-COMP 470 X4	
CP35			R90-1085-05	MULTI-COMP 22K X4	
CP37			R90-1085-05	MULTI-COMP 22K X4	
CP38			R90-1503-05	MULTI-COMP 47K X4	
CP39			R90-0723-05	MULTI-COMP 47K X2	
CP40,41			R90-1022-05	MULTI-COMP 470 X2	
R1			RK73GB2A471J	CHIP R 470 J 1/10W	
R2			RK73GB2A473J	CHIP R 47K J 1/10W	
R3			RK73GB2A104J	CHIP R 100K J 1/10W	
R4,5			RK73GB2A473J	CHIP R 47K J 1/10W	
R6			RK73GB2A104J	CHIP R 100K J 1/10W	
R7			RK73GB2A103J	CHIP R 10K J 1/10W	

E : Europe K : North America
M : Other Areas W : Without Europe

K : KDC-X969
M1 : KDC-9023R
E1 : KDC-PSW9524

△ Indicates safety critical components.

PARTS LIST

* New parts

Parts without **Parts No.** are not supplied.

Les articles non mentionnés dans le **Parts No.** ne sont pas fournis.

Teile ohne **Parts No.** werden nicht geliefert.

SUB-CIRCUIT UNIT (X16-2100-10)

Ref. No.	Add	New	Parts No.	Description	Destination
R8			RK73GB2A182J	CHIP R 1.8K J 1/10W	
R9			RK73GB2A220J	CHIP R 22 J 1/10W	
R10-12			RK73GB2A222J	CHIP R 2.2K J 1/10W	
R13			RK73GB2A101J	CHIP R 100 J 1/10W	
R14			RK73GB2A104J	CHIP R 100K J 1/10W	
R15			RK73GB2A102J	CHIP R 1.0K J 1/10W	
R16,17			RK73GB2A153J	CHIP R 15K J 1/10W	
R18,19			RK73GB2A274J	CHIP R 270K J 1/10W	
R20			RK73GB2A223J	CHIP R 22K J 1/10W	
R21			RK73GB2A333J	CHIP R 33K J 1/10W	
R22,23			RK73GB2A104J	CHIP R 100K J 1/10W	
R29			RK73GB2A104J	CHIP R 100K J 1/10W	
R30			RK73GB2A102J	CHIP R 1.0K J 1/10W	
R31			RK73GB2A471J	CHIP R 470 J 1/10W	
R32			RK73GB2A223J	CHIP R 22K J 1/10W	
R33-35			RK73GB2A102J	CHIP R 1.0K J 1/10W	
R36,37			RK73GB2A471J	CHIP R 470 J 1/10W	
R38			RK73GB2A101J	CHIP R 100 J 1/10W	
R39			RK73GB2A102J	CHIP R 1.0K J 1/10W	
R68			RK73GB2A100J	CHIP R 10 J 1/10W	
R69-72			RK73GB2A103J	CHIP R 10K J 1/10W	
R80			RK73GB2A101J	CHIP R 100 J 1/10W	
R81			RK73GB2A4R7J	CHIP R 4.7 J 1/10W	
R82			RK73GB2A102J	CHIP R 1.0K J 1/10W	
R83			RK73GB2A104J	CHIP R 100K J 1/10W	
D1-6			DA204U	DIODE	
D8-12			DA204U	DIODE	
D13			FTZ6.8E	ZENER DIODE	
D14			MA3062WA	ZENER DIODE	
ED1		*	CN2068M	FLUORESCENT INDICATOR TUBE	
IC2		*	MX23L3213TI112	MEMORY IC	
IC3		*	61LV641615TI	SRAM IC	
IC4			M25P20	ROM IC	
IC5			TC7SH08F	MOS-IC	
IC6			S-816A34AMC-T2	ANALOGUE IC	
IC7			TC74HC4050AFT	MOS-IC	
IC8			TC7WT126FU	MOS-IC	
IC9			RS-171	ANALOGUE IC	
IC10			BA3830F	ANALOGUE IC	
IC11		*	703107AGJ152	MI-COM IC	
Q1			2SB1188(Q,R)	TRANSISTOR	
Q2			2SA1163	TRANSISTOR	
Q3			2SC2713	TRANSISTOR	
Q4			DTA114EUA	DIGITAL TRANSISTOR	
Q4			UN5111	DIGITAL TRANSISTOR	
Q5			2SB1295	TRANSISTOR	
Q6			2SA1576A	TRANSISTOR	
Q7,8			2SC4081	TRANSISTOR	
Q10			DTC114EUA	DIGITAL TRANSISTOR	
Q10			UN5211	DIGITAL TRANSISTOR	
SWITCH UNIT (X16-2170-10)					
D1-11			B30-1605-05	LED (2COLOR PG/RED)	
D12			B30-1564-05	LED (1608, BLUE)	
D13			B30-1605-05	LED (2COLOR PG/RED)	
D14			B30-1564-05	LED (1608, BLUE)	

Ref. No.	Add	New	Parts No.	Description	Destination
D15			B30-1605-05	LED (2COLOR PG/RED)	
D16			B30-1564-05	LED (1608, BLUE)	
D17			B30-1605-05	LED (2COLOR PG/RED)	
D18,19			B30-1564-05	LED (1608, BLUE)	
D21			B30-1566-05	LED (1608, RED)	
C1-5			CK73GB1H103K	CHIP C 0.010UF K	
CN1		*	E41-0419-05	FLAT CABLE CONNECTOR	
R1			RK73FB2B241J	CHIP R 240 J 1/8W	
R3-5			RK73FB2B241J	CHIP R 240 J 1/8W	
R6,7			RK73FB2B301J	CHIP R 300 J 1/8W	
R8			RK73FB2B241J	CHIP R 240 J 1/8W	
R9			RK73FB2B301J	CHIP R 300 J 1/8W	
R10			RK73FB2B470J	CHIP R 47 J 1/8W	
R15			RK73GB2A241J	CHIP R 240 J 1/10W	
R16			RK73GB2A471J	CHIP R 470 J 1/10W	
R17			RK73GB2A103J	CHIP R 10K J 1/10W	
R18			RK73GB2A471J	CHIP R 470 J 1/10W	
R19			RK73GB2A103J	CHIP R 10K J 1/10W	
S1		*	S70-0901-05	TACT SWITCH	
S2,3			S70-0864-05	TACT SWITCH	
S4			S70-0856-05	TACT SWITCH	
S5-8			S70-0864-05	TACT SWITCH	
S9			S70-0856-05	TACT SWITCH	
S10-13			S70-0864-05	TACT SWITCH	
S14			S70-0856-05	TACT SWITCH	
S15-18			S70-0864-05	TACT SWITCH	
S19			S70-0856-05	TACT SWITCH	
S20			S70-0864-05	TACT SWITCH	
S21		*	T99-0445-05	ROTARY ENCODER	
D20			DAP202U	DIODE	
D20			MA142WA	DIODE	
D22			MA8068-M	ZENER DIODE	
Q1			DTA114YUA	DIGITAL TRANSISTOR	
Q2,3			2SC4081	TRANSISTOR	
SUB-CIRCUIT UNIT (X16-2210-10)					
315	2C	*	E58-0968-05	RECTANGULAR RECEPTACLE	
FPC3	2C	*	J84-0154-05	FLEXIBLE PRINTED WIRING BOARD	
ELECTRIC UNIT (X25-964x-xx)					
C2			CK73GB1H103K	CHIP C 0.010UF K	
C3			C90-2866-05	ELECTRO 220UF 16WV	
C4			CK73GB1H103K	CHIP C 0.010UF K	
C5			CE04NW1C100M	ELECTRO 10UF 16WV	
C6			CE04NW0J101M	ELECTRO 100UF 6.3WV	
C7			CK73FB1C105K	CHIP C 1.0UF K	
C8			CE04CW1A221M	ELECTRO 220UF 10WV	
C9			CE04CW1A101M	ELECTRO 100UF 10WV	
C10		*	CE32AZ1E221M	CHIP EL 220UF 25WV	
C11			CK73GB1H332K	CHIP C 3300PF K	
C12		*	CE32AZ1C221M	CHIP EL 220UF 16WV	
C13			CK73GB0J105K	CHIP C 1.0UF K	
C14			CK73EB1C225K	CHIP C 2.2UF K	

E : Europe K : North America
M : Other Areas W : Without Europe

K : KDC-X969
M1 : KDC-9023R
E1 : KDC-PSW9524

△ Indicates safety critical components.

PARTS LIST

* New parts

Parts without **Parts No.** are not supplied.

Les articles non mentionnés dans le **Parts No.** ne sont pas fournis.

Teile ohne **Parts No.** werden nicht geliefert.

ELECTRIC UNIT (X25-964x-xx)

Ref. No.	A d	N e w	Parts No.	Description	Desti- nation
C15			CK73GB1H103K	CHIP C 0.010UF K	
C16		*	CE32AZ1C101M	CHIP EL 100UF 16WV	
C17			CK73GB1H103K	CHIP C 0.010UF K	
C18		*	CE32AZ1C101M	CHIP EL 100UF 16WV	
C21			CK73FB1A225K	CHIP C 2.2UF K	
C22			C93-1218-05	CHIP C 0.010UF K	
C23			C90-5375-05	ELECTRO 33UF 63WV.	
C30			CE04NW1E4R7M	ELECTRO 4.7UF 25WV	
C31			C90-2962-05	ELECTRO 100UF 16WV	
C32-35			CK73EB1C225K	CHIP C 2.2UF K	
C36			CE04NW1C220M	ELECTRO 22UF 16WV	
C37			CK73GB1E223K	CHIP C 0.022UF K	
C37			CK73GB1H223K	CHIP C 0.022UF K	
C38			CK73GB1H103K	CHIP C 0.010UF K	
C39,40			CK73EB1C225K	CHIP C 2.2UF K	
C41			CK73GB1H103K	CHIP C 0.010UF K	M1E1
C42			CK73GB1E223K	CHIP C 0.022UF K	
C42			CK73GB1H223K	CHIP C 0.022UF K	
C43			CK73FB1C105K	CHIP C 1.0UF K	
C44,45			CK73GB1H103K	CHIP C 0.010UF K	
C46			CK73GB1H102K	CHIP C 1000PF K	
C48			CK73GB1H103K	CHIP C 0.010UF K	
C100			C90-2822-05	ELECTRO 3900UF 16WV	M1
C100			C90-5484-05	ELECTRO 3900UF 16WV	KE1
C101			CE04NW0J470M	ELECTRO 47UF 6.3WV	
C102			CC73GCH1H220J	CHIP C 22PF J	
C103			CC73GCH1H270J	CHIP C 27PF J	
C104			CK73GB0J105K	CHIP C 1.0UF K	
C106			CK73GB0J105K	CHIP C 1.0UF K	
C107			CK73GB1H103K	CHIP C 0.010UF K	
C109			CK73GB1H102K	CHIP C 1000PF K	
C110,111			CK73GB1H103K	CHIP C 0.010UF K	
C199			CK73GB1C104K	CHIP C 0.10UF K	
C199			CK73GB1H104K	CHIP C 0.10UF K	
C201,202			CE04NW1HR47M	ELECTRO 0.47UF 50WV	
C203,204			CK73FB1C474K	CHIP C 0.47UF K	KM1
C205,206			CE04NW0J470M	ELECTRO 47UF 6.3WV	KM1
C206			CE04NW0J470M	ELECTRO 47UF 6.3WV	E1
C207,208			CK73FB1C474K	CHIP C 0.47UF K	
C209			CK73GB1E223K	CHIP C 0.022UF K	
C209			CK73GB1H223K	CHIP C 0.022UF K	
C210			CK73GB1H103K	CHIP C 0.010UF K	
C211			CK73GB1A474K	CHIP C 0.47UF K	
C212			CC73GCH1H151J	CHIP C 150PF J	
C213			CK73GB1C104K	CHIP C 0.10UF K	
C213			CK73GB1H104K	CHIP C 0.10UF K	
C214			CK73GB1H103K	CHIP C 0.010UF K	
C215			CE04NW1C470M	ELECTRO 47UF 16WV	
C216-223			CK73FB1C105K	CHIP C 1.0UF K	
C224			CK73GB1C104K	CHIP C 0.10UF K	
C224			CK73GB1H104K	CHIP C 0.10UF K	
C225			CK73GB1H103K	CHIP C 0.010UF K	
C226-231			CK73GB1E473K	CHIP C 0.047UF K	
C226-231			CK73GB1H473K	CHIP C 0.047UF K	
C232			CK73FB1C105K	CHIP C 1.0UF K	

Ref. No.	A d	N e w	Parts No.	Description	Desti- nation
C233			C92-0667-05	ELECTRO 10UF 10WV	
C234			CK73GB1E333K	CHIP C 0.033UF K	
C234			CK73GB1H333K	CHIP C 0.033UF K	
C235			CK73GB1H103K	CHIP C 0.010UF K	
C236			CK73GB1A334K	CHIP C 0.33UF K	
C237			CK73GB1A474K	CHIP C 0.47UF K	
C238			CC73GCH1H221J	CHIP C 220PF J	
C239			CK73GB1H103K	CHIP C 0.010UF K	
C240,241			C92-0667-05	ELECTRO 10UF 10WV	
C250		*	CE32AT1H2R2M	CHIP EL 2.2UF 50WV	KE1
C250			C92-0687-05	ELECTRO 2.2UF 50WV	M1
C251			CK73FB1C334K	CHIP C 0.33UF K	
C252			CK73GB1A334K	CHIP C 0.33UF K	
C253			CK73FB1C334K	CHIP C 0.33UF K	
C254			CK73GB1A334K	CHIP C 0.33UF K	
C255			CK73FB1C334K	CHIP C 0.33UF K	
C256			CK73GB1A334K	CHIP C 0.33UF K	
C257			CK73FB1C334K	CHIP C 0.33UF K	
C258			CK73GB1A334K	CHIP C 0.33UF K	
C259		*	CE32AT1H010M	CHIP EL 1.0UF 50WV	KE1
C259			C92-0686-05	ELECTRO 1UF 50WV	M1
C260-263			CK73GB1C104K	CHIP C 0.10UF K	
C260-263			CK73GB1H104K	CHIP C 0.10UF K	
C264,265			CE04NW1C220M	ELECTRO 22UF 16WV	
C266,267			CE04NW1C100M	ELECTRO 10UF 16WV	
C268,269			CE04NW1C220M	ELECTRO 22UF 16WV	
C270,271			CE04NW1C100M	ELECTRO 10UF 16WV	
C272-275			C90-5296-05	NP-ELECT 0.22UF 50WV	
C276			CK73FB1C105K	CHIP C 1.0UF K	
C277			CE04NW1C330M	ELECTRO 33UF 16WV	
C278			C90-2935-05	ELECTRO 1.0UF 50WV	
C279			CE04NW1H010M	ELECTRO 1.0UF 50WV	
C280-285			CK73GB1H222K	CHIP C 2200PF K	
C286			CK73GB1H103K	CHIP C 0.010UF K	KM1
C287-289			CK73FB1H104K	CHIP C 0.10UF K	
C290,291			CK73GB1H103K	CHIP C 0.010UF K	
C292-296			CK73EB1A475K	CHIP C 4.7UF K	
C297,298			C92-0672-05	ELECTRO 22UF 16WV	
C299,300			CE04NW1C100M	ELECTRO 10UF 16WV	
C303-305			CK73GB1H103K	CHIP C 0.010UF K	
C307			CK73GB1H103K	CHIP C 0.010UF K	
C309,310			CC73GCH1H100D	CHIP C 10PF D	
C311			CC73GCH1H331J	CHIP C 330PF J	
C312			CK73FB1A225K	CHIP C 2.2UF K	
C313			CK73GB1H103K	CHIP C 0.010UF K	
C314			CE04NW1C100M	ELECTRO 10UF 16WV	
C316-319			CK73GB1A224K	CHIP C 0.22UF K	
C501			CK73FB1C105K	CHIP C 1.0UF K	M1E1
C502-504			CK73GB1H103K	CHIP C 0.010UF K	
C601,602			CK73GB1C104K	CHIP C 0.10UF K	
C601,602			CK73GB1H104K	CHIP C 0.10UF K	
C603			CK73GB1H103K	CHIP C 0.010UF K	
C701			CK73GB1A474K	CHIP C 0.47UF K	
CN1			E41-0224-05	PIN ASSY	

E : Europe K : North America
M : Other Areas W : Without Europe

K : KDC-X969
M1 : KDC-9023R
E1 : KDC-PSW9524

△ Indicates safety critical components.

PARTS LIST

* New parts

Parts without **Parts No.** are not supplied.

Les articles non mentionnés dans le **Parts No.** ne sont pas fournis.

Teile ohne **Parts No.** werden nicht geliefert.

ELECTRIC UNIT (X25-964x-xx)

Ref. No.	Add	New	Parts No.	Description	Destination
CN2			E40-3237-05	PIN ASSY	
CN3		*	E41-0384-05	PIN ASSY	
CN4			E40-9527-05	FLAT CABLE CONNECTOR	
CN4			E41-0213-05	FLAT CABLE CONNECTOR	
CN5			E40-9368-05	FLAT CABLE CONNECTOR	
CN6		*	E41-0399-05	FLAT CABLE CONNECTOR	
CN7			E41-0009-05	PIN ASSY	
△ J1			E58-0863-15	RECTANGULAR RECEPTACLE	
W2		*	E30-6218-05	CORD WITH PLUG	
L1			L33-1170-05	CHOKO COIL ASSY	
L2			L33-1126-05	CHOKO COIL	
L3			L33-1029-05	SMALL FIXED INDUCTOR	
L4			L40-2205-34	SMALL FIXED INDUCTOR (22UH)	
L7			L33-1039-05	LINE FILTER COIL	
L101			L40-4795-34	SMALL FIXED INDUCTOR	
L101			L40-4795-68	SMALL FIXED INDUCTOR (4.7UH)	
L102			L92-0075-05	CHIP FERRITE	
L201			L40-4795-34	SMALL FIXED INDUCTOR	
L201			L40-4795-68	SMALL FIXED INDUCTOR (4.7UH)	
L303-307			L40-4795-34	SMALL FIXED INDUCTOR	
L303-307			L40-4795-68	SMALL FIXED INDUCTOR (4.7UH)	
X1			L78-0821-05	RESONATOR	
X2			L77-2738-05	CRYSTAL RESONATOR	
X3			L77-2002-05	CRYSTAL RESONATOR	
U	2D		N83-3005-46	PAN HEAD TAPTITE SCREW	
X	2D		N80-3008-46	PAN HEAD TAPTITE SCREW	
Y	2D		N83-3010-46	PAN HEAD TAPTITE SCREW	
Z	2D		N84-2004-46	PAN HEAD TAPTITE SCREW	
R1			RK73FB2B223J	CHIP R 22K J 1/8W	
R2			RK73GB2A101J	CHIP R 100 J 1/10W	
R3			RK73GB2A223J	CHIP R 22K J 1/10W	
R4			RK73GB2A222J	CHIP R 2.2K J 1/10W	
R5			RK73FB2B221J	CHIP R 220 J 1/8W	
R6			RK73GB2A153J	CHIP R 15K J 1/10W	
R7			R92-3032-05	CHIP R 4.3K D 1/10W	
R8			R92-3047-05	CHIP R 24K D 1/10W	
R9			RK73FB2B152J	CHIP R 1.5K J 1/8W	
R10			R92-3022-05	METAL R 750 D 1/10W	
R11			R92-3028-05	CHIP R 2.2K D 1/10W	
R12			RK73GB2A103J	CHIP R 10K J 1/10W	
R13			R92-2104-05	CHIP R 2.2 J 1W	
R14			RK73FB2B751J	CHIP R 750 J 1/8W	
R15			RK73GB2A473J	CHIP R 47K J 1/10W	
R16			RK73FB2B103J	CHIP R 10K J 1/8W	
R17			RK73GB2A102J	CHIP R 1.0K J 1/10W	
R18			RK73GB2A750J	CHIP R 75 J 1/10W	
R19			RK73GB2A272J	CHIP R 2.7K J 1/10W	
R20			RK73GB2A470J	CHIP R 47 J 1/10W	
R21			RK73GB2A752J	CHIP R 7.5K J 1/10W	
R22			RK73GB2A274J	CHIP R 270K J 1/10W	
R23			RK73GB2A563J	CHIP R 56K J 1/10W	
R24			RK73GB2A470J	CHIP R 47 J 1/10W	
R25			RK73GB2A103J	CHIP R 10K J 1/10W	
R26,27			RK73GB2A913J	CHIP R 91K J 1/10W	

Ref. No.	Add	New	Parts No.	Description	Destination
R28			RK73FB2B472J	CHIP R 4.7K J 1/8W	
R29			RD14DB2H102J	SMALL-RD 1.0K J 1/2W	K
R30			RK73GB2A223J	CHIP R 22K J 1/10W	K
R31			RK73FB2B472J	CHIP R 4.7K J 1/8W	
R32			RK73FB2B561J	CHIP R 560 J 1/8W	
R33			RK73GB2A473J	CHIP R 47K J 1/10W	M1E1
R34			RK73GB2A223J	CHIP R 22K J 1/10W	M1E1
R34,35			RK73GB2A104J	CHIP R 100K J 1/10W	K
R35			RK73GB2A104J	CHIP R 100K J 1/10W	M1E1
R36			RK73FB2B103J	CHIP R 10K J 1/8W	
R37			RK73GB2A103J	CHIP R 10K J 1/10W	
R38			RK73GB2A822J	CHIP R 8.2K J 1/10W	
R41			RK73GB2A223J	CHIP R 22K J 1/10W	
R42			RD14DB2H332J	SMALL-RD 3.3K J 1/2W	
R43			RK73EB2E473J	CHIP R 47K J 1/4W	
R44			RK73GB2A183J	CHIP R 18K J 1/10W	
R45			RK73GB2A104J	CHIP R 100K J 1/10W	
R46			RK73EB2E103J	CHIP R 10K J 1/4W	K
R46,47			RK73EB2E103J	CHIP R 10K J 1/4W	M1E1
R48			RK73EB2E102J	CHIP R 1.0K J 1/4W	
R49			RD14DB2H102J	SMALL-RD 1.0K J 1/2W	K
R101			RK73GB2A103J	CHIP R 10K J 1/10W	
R102			RK73GB2A153J	CHIP R 15K J 1/10W	
R103			RK73GB2A104J	CHIP R 100K J 1/10W	
R106			RK73GB2A103J	CHIP R 10K J 1/10W	M1
R108,109			RK73GB2A103J	CHIP R 10K J 1/10W	KE1
R109			RK73GB2A103J	CHIP R 10K J 1/10W	M1
R110			RK73GB2A104J	CHIP R 100K J 1/10W	
R111,112			RK73GB2A103J	CHIP R 10K J 1/10W	
R115,116			RK73GB2A102J	CHIP R 1.0K J 1/10W	
R117			RK73GB2A103J	CHIP R 10K J 1/10W	
R118-120			RK73GB2A102J	CHIP R 1.0K J 1/10W	
R121			RK73GB2A222J	CHIP R 2.2K J 1/10W	
R122-126			RK73GB2A101J	CHIP R 100 J 1/10W	E1
R122,123			RK73GB2A101J	CHIP R 100 J 1/10W	KM1
R127			RK73GB2A102J	CHIP R 1.0K J 1/10W	
R128			RK73GB2A104J	CHIP R 100K J 1/10W	
R129			RK73GB2A102J	CHIP R 1.0K J 1/10W	
R130			RK73GB2A104J	CHIP R 100K J 1/10W	
R131			RK73GB2A102J	CHIP R 1.0K J 1/10W	
R132			RK73GB2A104J	CHIP R 100K J 1/10W	
R133-136			RK73GB2A222J	CHIP R 2.2K J 1/10W	
R137			RK73GB2A102J	CHIP R 1.0K J 1/10W	
R138-140			RK73GB2A222J	CHIP R 2.2K J 1/10W	
R141			RK73GB2A102J	CHIP R 1.0K J 1/10W	
R142,143			RK73GB2A222J	CHIP R 2.2K J 1/10W	
R144			RK73GB2A102J	CHIP R 1.0K J 1/10W	
R145,146			RK73GB2A473J	CHIP R 47K J 1/10W	
R150,151			RK73GB2A104J	CHIP R 100K J 1/10W	
R152,153			RK73GB2A222J	CHIP R 2.2K J 1/10W	
R156			RK73GB2A104J	CHIP R 100K J 1/10W	
R158			RK73GB2A104J	CHIP R 100K J 1/10W	
R159,160			RK73GB2A471J	CHIP R 470 J 1/10W	
R161			RK73GB2A104J	CHIP R 100K J 1/10W	
R162			RK73GB2A103J	CHIP R 10K J 1/10W	

E : Europe K : North America
M : Other Areas W : Without Europe

K : KDC-X969
M1 : KDC-9023R
E1 : KDC-PSW9524

△ Indicates safety critical components.

PARTS LIST

* New parts

Parts without **Parts No.** are not supplied.

Les articles non mentionnés dans le **Parts No.** ne sont pas fournis.

Teile ohne **Parts No.** werden nicht geliefert.

ELECTRIC UNIT (X25-964x-xx)

Ref. No.	A d	N e w	Parts No.	Description	Desti- nation
R163,164			RK73GB2A471J	CHIP R 470 J 1/10W	
R165,166			RK73GB2A472J	CHIP R 4.7K J 1/10W	
R167			RK73GB2A102J	CHIP R 1.0K J 1/10W	
R169			RK73GB2A102J	CHIP R 1.0K J 1/10W	
R170			RK73GB2A222J	CHIP R 2.2K J 1/10W	
R171,172			RK73GB2A471J	CHIP R 470 J 1/10W	
R173,174			RK73GB2A472J	CHIP R 4.7K J 1/10W	
R175			RK73GB2A333J	CHIP R 33K J 1/10W	
R176			RK73GB2A473J	CHIP R 47K J 1/10W	
R177			RK73GB2A222J	CHIP R 2.2K J 1/10W	
R178,179			RK73GB2A103J	CHIP R 10K J 1/10W	
R180			RK73GB2A222J	CHIP R 2.2K J 1/10W	
R181			RK73GB2A473J	CHIP R 47K J 1/10W	
R182			RK73GB2A104J	CHIP R 100K J 1/10W	
R183,184			RK73GB2A222J	CHIP R 2.2K J 1/10W	
R185			RK73GB2A103J	CHIP R 10K J 1/10W	M1E1
R186			RK73GB2A102J	CHIP R 1.0K J 1/10W	
R201			RK73GB2A103J	CHIP R 10K J 1/10W	
R202-204			RK73GB2A472J	CHIP R 4.7K J 1/10W	
R205			RK73GB2A134J	CHIP R 130K J 1/10W	
R206			RK73GB2A823J	CHIP R 82K J 1/10W	
R207			RK73GB2A473J	CHIP R 47K J 1/10W	
R208			RK73GB2A912J	CHIP R 9.1K J 1/10W	
R209			RK73GB2A363J	CHIP R 36K J 1/10W	
R210			RK73GB2A622J	CHIP R 6.2K J 1/10W	
R217			RK73GB2A682J	CHIP R 6.8K J 1/10W	
R218			RK73GB2A332J	CHIP R 3.3K J 1/10W	
R219			RK73GB2A392J	CHIP R 3.9K J 1/10W	
R220,221			RK73FB2B361J	CHIP R 360 J 1/8W	
R222,223			RK73FB2B222J	CHIP R 2.2K J 1/8W	
R224,225			RK73FB2B103J	CHIP R 10K J 1/8W	
R226,227			RK73FB2B223J	CHIP R 22K J 1/8W	
R228,229			RK73FB2B820J	CHIP R 82 J 1/8W	
R232,233			RK73FB2B361J	CHIP R 360 J 1/8W	
R234,235			RK73FB2B222J	CHIP R 2.2K J 1/8W	
R236,237			RK73FB2B103J	CHIP R 10K J 1/8W	
R238,239			RK73FB2B223J	CHIP R 22K J 1/8W	
R240,241			RK73FB2B820J	CHIP R 82 J 1/8W	
R244,245			RK73FB2B361J	CHIP R 360 J 1/8W	
R246,247			RK73FB2B222J	CHIP R 2.2K J 1/8W	
R248,249			RK73FB2B103J	CHIP R 10K J 1/8W	
R250,251			RK73FB2B223J	CHIP R 22K J 1/8W	
R252,253			RK73FB2B820J	CHIP R 82 J 1/8W	
R256			RK73GB2A221J	CHIP R 220 J 1/10W	
R257			RK73GB2A223J	CHIP R 22K J 1/10W	
R259			RK73GB2A432J	CHIP R 4.3K J 1/10W	
R260			RK73GB2A100J	CHIP R 10 J 1/10W	
R261			RK73GB2A752J	CHIP R 7.5K J 1/10W	
R262			RK73EB2E4R7J	CHIP R 4.7 J 1/4W	KM1
R263,264			RK73EB2E100J	CHIP R 10 J 1/4W	KM1
R265,266			RK73GB2A102J	CHIP R 1.0K J 1/10W	KM1
R266			RK73GB2A102J	CHIP R 1.0K J 1/10W	E1
R267			RK73EB2E100J	CHIP R 10 J 1/4W	
R268			RK73EB2E4R7J	CHIP R 4.7 J 1/4W	
R269			RK73EB2E100J	CHIP R 10 J 1/4W	

Ref. No.	A d	N e w	Parts No.	Description	Desti- nation
R270			RK73GB2A473J	CHIP R 47K J 1/10W	
R271			RK73GB2A821J	CHIP R 820 J 1/10W	
R272,273			RK73GB2A103J	CHIP R 10K J 1/10W	
R274			RK73GB2A153J	CHIP R 15K J 1/10W	
R275			RK73GB2A473J	CHIP R 47K J 1/10W	
R276			RK73GB2A102J	CHIP R 1.0K J 1/10W	
R277			RK73GB2A473J	CHIP R 47K J 1/10W	
R278			RK73GB2A333J	CHIP R 33K J 1/10W	
R279,280			RK73GB2A334J	CHIP R 330K J 1/10W	
R303			RK73FB2B102J	CHIP R 1.0K J 1/8W	
R304			RK73GB2A223J	CHIP R 22K J 1/10W	
R305			RK73GB2A472J	CHIP R 4.7K J 1/10W	
R306-308			RK73GB2A222J	CHIP R 2.2K J 1/10W	
R501,502			RK73EB2E101J	CHIP R 100 J 1/4W	
R503-507			RK73EB2E472J	CHIP R 4.7K J 1/4W	
R508			RK73EB2E101J	CHIP R 100 J 1/4W	E1
R509-511			RK73EB2E471J	CHIP R 470 J 1/4W	E1
R512			RK73EB2E102J	CHIP R 1.0K J 1/4W	
R513			RK73GB2A223J	CHIP R 22K J 1/10W	
R514-516			RK73GB2A472J	CHIP R 4.7K J 1/10W	
R517,518			RK73EB2E101J	CHIP R 100 J 1/4W	
R519			RK73EB2E471J	CHIP R 470 J 1/4W	
R520			RK73EB2E472J	CHIP R 4.7K J 1/4W	
R522-524			RK73GB2A222J	CHIP R 2.2K J 1/10W	
R525			RK73GB2A102J	CHIP R 1.0K J 1/10W	
R526,527			RK73GB2A473J	CHIP R 47K J 1/10W	
R601,602			RK73GB2A104J	CHIP R 100K J 1/10W	
R603			RK73GB2A222J	CHIP R 2.2K J 1/10W	
R604,605			RK73GB2A103J	CHIP R 10K J 1/10W	
R606			RK73GB2A222J	CHIP R 2.2K J 1/10W	
R607			RK73GB2A911J	CHIP R 910 J 1/10W	
R608,609			RK73GB2A104J	CHIP R 100K J 1/10W	
R610			RK73GB2A222J	CHIP R 2.2K J 1/10W	
R611,612			RK73GB2A103J	CHIP R 10K J 1/10W	
R613			RK73GB2A222J	CHIP R 2.2K J 1/10W	
R614			RK73GB2A911J	CHIP R 910 J 1/10W	
R615-618			RK73GB2A102J	CHIP R 1.0K J 1/10W	
R620			RK73EB2E102J	CHIP R 1.0K J 1/4W	
R621			RK73GB2A472J	CHIP R 4.7K J 1/10W	
R623,624			RK73GB2A332J	CHIP R 3.3K J 1/10W	
R625,626			RK73GB2A102J	CHIP R 1.0K J 1/10W	
R701			RK73GB2A104J	CHIP R 100K J 1/10W	
W3			R92-1252-05	CHIP R 0 OHM J 1/16W	M1E1
D1			1N5393G-M5	DIODE	
D2			RB160L-40	DIODE	
D3			MA8056-M	ZENER DIODE	
D4			MA8082-L	ZENER DIODE	
D5			SFPB-54V	DIODE	
D6			MA8100-L	ZENER DIODE	
D7			MA4062(N)-L	ZENER DIODE	
D8			MA8110-M	ZENER DIODE	
D9			MA8056-M	ZENER DIODE	
D16			MA3056-M	ZENER DIODE	
D17			MA3047-M	ZENER DIODE	M1E1

E : Europe K : North America
M : Other Areas W : Without Europe

K : KDC-X969
M1 : KDC-9023R
E1 : KDC-PSW9524

△ Indicates safety critical components.

PARTS LIST

* New parts

Parts without **Parts No.** are not supplied.

Les articles non mentionnés dans le **Parts No.** ne sont pas fournis.

Teile ohne **Parts No.** werden nicht geliefert.

ELECTRIC UNIT (X25-964x-xx)

Ref. No.	Add	New	Parts No.	Description	Destination	Ref. No.	Add	New	Parts No.	Description	Destination
D18			MA8068-M	ZENER DIODE		Q15			2SB1443	TRANSISTOR	
D19			MA8062-M	ZENER DIODE		Q16,17			2SC4081	TRANSISTOR	
D20,21			DAP202U	DIODE		Q18,19			2SA1576A	TRANSISTOR	
D20,21			MA142WA	DIODE		Q20			2SC4081	TRANSISTOR	
D101			DAP202U	DIODE		Q21			2SA1576A	TRANSISTOR	
D101			MA142WA	DIODE		Q22			2SC4081	TRANSISTOR	
D201,202			RD6.8M(B2)	ZENER DIODE		Q23			DTC114YUA	DIGITAL TRANSISTOR	K
D203			RD6.8MW	ZENER DIODE	KM1	Q23			UN5214	DIGITAL TRANSISTOR	K
D204,205			RD6.8M(B2)	ZENER DIODE	KM1	Q24			2SB1240	TRANSISTOR	K
D205			RD6.8M(B2)	ZENER DIODE	E1	Q25			DTA123JK	DIGITAL TRANSISTOR	
D206			RD6.8MW	ZENER DIODE		Q25			KRA105S	DIGITAL TRANSISTOR	
D207,208			DAP202U	DIODE		Q26			DTC144EUA	DIGITAL TRANSISTOR	
D207,208			MA142WA	DIODE		Q26			UN5213	DIGITAL TRANSISTOR	
D209-216			S1J	DIODE		Q27			2SC4081	TRANSISTOR	
D209-216			1SR154-400	DIODE		Q29			2SC4081	TRANSISTOR	
D217			DA204K	DIODE		Q30,31			DTA124EUA	DIGITAL TRANSISTOR	
D301			IMSA-6801	SURGE ABSORBER		Q30,31			UN5112	DIGITAL TRANSISTOR	
D501-505			MA3062WA	ZENER DIODE	E1	Q201			DTC143TUA	DIGITAL TRANSISTOR	
D503-505			MA3062WA	ZENER DIODE	KM1	Q201			UN5216	DIGITAL TRANSISTOR	
D506-509			DA204K	DIODE		Q202			DTC124EUA	DIGITAL TRANSISTOR	
D601			DA204K	DIODE		Q202			UN5212	DIGITAL TRANSISTOR	
IC1		*	703033BGC020	MI-COM IC		Q203-208			DTC143TUA	DIGITAL TRANSISTOR	
IC2			TDA7411	ANALOGUE IC		Q203-208			UN5216	DIGITAL TRANSISTOR	
IC3			M5237ML	ANALOGUE IC		Q210			2SC4081	TRANSISTOR	
IC4			TDA7560	ANALOGUE IC		Q303			DTC124EUA	DIGITAL TRANSISTOR	
IC5			TDA7401	ANALOGUE IC		Q303			UN5212	DIGITAL TRANSISTOR	
IC6		*	NJM2195FJ1	ANALOGUE IC		Q304			2SB1188(Q,R)	TRANSISTOR	
IC7			ICL7660SIBA	ANALOGUE IC		Q305			DTC143TUA	DIGITAL TRANSISTOR	
IC8			S-80837CNNB	MOS-IC		Q305			UN5216	DIGITAL TRANSISTOR	
IC9			TC74HC02AF	MOS-IC		Q501			DTA124EUA	DIGITAL TRANSISTOR	
IC10-13			NJM4565M-TE2	ANALOGUE IC		Q501			UN5112	DIGITAL TRANSISTOR	
IC14			TDA7479D	ANALOGUE IC		Q502			2SB1427	TRANSISTOR	
IC15,16			LB1930M	ANALOGUE IC		Q503			DTC124EUA	DIGITAL TRANSISTOR	
IC17			BR24C01AF-W	ROM IC		Q503			UN5212	DIGITAL TRANSISTOR	
IC18			L9820D013TR	ANALOGUE IC		Q601			DTC124EUA	DIGITAL TRANSISTOR	
IC19			LM2672M-ADJ	ANALOGUE IC		Q601			UN5212	DIGITAL TRANSISTOR	
IC20		*	TC7W66FK	MOS-IC		Q602			2SC4081	TRANSISTOR	
Q1			2SA2057	TRANSISTOR		Q603			DTC124EUA	DIGITAL TRANSISTOR	
Q2			2SC4081	TRANSISTOR		Q603			UN5212	DIGITAL TRANSISTOR	
Q3			2SA1576A	TRANSISTOR		TH1			PTH9C42BD471Q	POSITIVE RESISTOR	
Q4			DTA124EUA	DIGITAL TRANSISTOR		A2		*	W02-3430-05	ELECTRIC CIRCUIT MODULE	
Q4			UN5112	DIGITAL TRANSISTOR		A1		*	X86-3730-11	FRONT-END UNIT	K
Q5			DTC124EUA	DIGITAL TRANSISTOR		A1		*	X86-3732-70	FRONT-END UNIT	M1E1
Q5			UN5212	DIGITAL TRANSISTOR		CD PLAYER UNIT (X32-5440-00)					
Q6			DTC144EUA	DIGITAL TRANSISTOR		C1			C92-0628-05	CHIP-TAN 10UF 10WV	
Q6			UN5213	DIGITAL TRANSISTOR		C2			CK73FB1A105K	CHIP C 1.0UF K	
Q7			DTA124EUA	DIGITAL TRANSISTOR		C3			CK73FB1A225K	CHIP C 2.2UF K	
Q7			UN5112	DIGITAL TRANSISTOR		C4			CK73GB1H103K	CHIP C 0.010UF K	
Q8,9			2SA2057	TRANSISTOR		C5			CC73GCH1H680J	CHIP C 68PF J	
Q11			DTC124EUA	DIGITAL TRANSISTOR		C6			CC73GCH1H681J	CHIP C 680PF J	
Q11			UN5212	DIGITAL TRANSISTOR		C7			CK73GB1H104K	CHIP C 0.10UF K	
Q12			DTA124EUA	DIGITAL TRANSISTOR		C8			CK73GB1H222K	CHIP C 2200PF K	
Q12			UN5112	DIGITAL TRANSISTOR		C9,10			CK73GB1H104K	CHIP C 0.10UF K	
Q13			2SA2057	TRANSISTOR		C11			CC73GCH1H681J	CHIP C 680PF J	
Q14			2SC4081	TRANSISTOR							

E : Europe K : North America
M : Other Areas W : Without Europe

K : KDC-X969
M1 : KDC-9023R
E1 : KDC-PSW9524

△ Indicates safety critical components.

PARTS LIST

* New parts

Parts without **Parts No.** are not supplied.

Les articles non mentionnés dans le **Parts No.** ne sont pas fournis.

Teile ohne **Parts No.** werden nicht geliefert.

CD PLAYER UNIT (X32-5440-00)

Ref. No.	A d	N e w	Parts No.	Description	Desti- nation
C12			CK73GB1H222K	CHIP C 2200PF K	
C13			CC73GCH1H680J	CHIP C 68PF J	
C15			CK73EB1A475K	CHIP C 4.7UF K	
C16			CK73GB1H104K	CHIP C 0.10UF K	
C17			CK73GB1H331K	CHIP C 330PF K	
C18			CK73GB1H472K	CHIP C 4700PF K	
C19,20			CK73GB1H104K	CHIP C 0.10UF K	
C21			CK73EB1A475K	CHIP C 4.7UF K	
C22			CK73GB0J105K	CHIP C 1.0UF K	
C23,24			CK73FB1A225K	CHIP C 2.2UF K	
C25			C92-0712-05	CHIP-TAN 22UF 6.3WV	
C26			CK73GB1H104K	CHIP C 0.10UF K	
C27			C92-0712-05	CHIP-TAN 22UF 6.3WV	
C28			CK73GB1H102K	CHIP C 1000PF K	
C29			CK73GB1H331K	CHIP C 330PF K	
C30			CK73GB1H152K	CHIP C 1500PF K	
C31-35			CK73GB1H104K	CHIP C 0.10UF K	
C36			C92-0712-05	CHIP-TAN 22UF 6.3WV	
C37			CK73EB1A475K	CHIP C 4.7UF K	
C38-41			CK73GB1H104K	CHIP C 0.10UF K	
C42,43			CK73EB1A475K	CHIP C 4.7UF K	
C44,45			CK73GB1H102K	CHIP C 1000PF K	
C46			CK73GB1H104K	CHIP C 0.10UF K	
C47			C92-0628-05	CHIP-TAN 10UF 10WV	
C48			CK73GB1H104K	CHIP C 0.10UF K	
C50,51			CK73GB1H104K	CHIP C 0.10UF K	
C52			CK73GB1H152K	CHIP C 1500PF K	
C53,54			CK73GB1H104K	CHIP C 0.10UF K	
C55			CC73GCH1H470J	CHIP C 47PF J	
C56			CC73GCH1H820J	CHIP C 82PF J	
C57-61			CK73GB1H104K	CHIP C 0.10UF K	
C63			CC73GCH1H020C	CHIP C 2.0PF C	
C64-66			CK73GB1H104K	CHIP C 0.10UF K	
C67			CK73GB1H222K	CHIP C 2200PF K	
C68			CC73GCH1H060D	CHIP C 6.0PF D	
C69-73			CK73GB1H104K	CHIP C 0.10UF K	
C74			CK73GB1H682K	CHIP C 6800PF K	
C75			CK73GB1H332K	CHIP C 3300PF K	
C76			CK73GB1H103K	CHIP C 0.010UF K	
C77			CK73GB1H104K	CHIP C 0.10UF K	
C78			CK73EB1A475K	CHIP C 4.7UF K	
C79-82			CK73GB1H152K	CHIP C 1500PF K	
C83			CK73GB1H104K	CHIP C 0.10UF K	
C84			C92-0628-05	CHIP-TAN 10UF 10WV	
C85,86			CK73GB1H104K	CHIP C 0.10UF K	
C87			CK73EB1A475K	CHIP C 4.7UF K	
C88			CK73GB1H104K	CHIP C 0.10UF K	
CN1			E41-0213-05	FLAT CABLE CONNECTOR	
CN2			E40-9536-05	FLAT CABLE CONNECTOR	
L1,2			L92-0329-05	CHIP FERRITE	
L4,5			L92-0329-05	CHIP FERRITE	
X1			L78-0851-05	RESONATOR (16.93MHZ)	
X2			L78-0862-05	RESONATOR (16.00MHZ)	
X3			L78-0861-05	RESONATOR (24.57MHZ)	

Ref. No.	A d	N e w	Parts No.	Description	Desti- nation
CP1,2			R90-1019-05	MULTI-COMP 100 X2	
CP4			R90-0719-05	MULTI-COMP 4.7K X2	
CP6			R90-1019-05	MULTI-COMP 100 X2	
CP8			R90-0737-05	MULTI-COMP 100K X2	
CP9-13			R90-0720-05	MULTI-COMP 100K X4	
CP14			R90-1019-05	MULTI-COMP 100 X2	
CP15			R90-0718-05	MULTI-COMP 4.7K X4	
CP16-22			R90-1014-05	MULTI-COMP 100 X4	
CP23			R90-0714-05	MULTI-COMP 10K X4	
R1			R92-3044-05	CHIP R 18K D 1/10W	
R2			R92-3041-05	CHIP R 11K D 1/10W	
R3			RK73FB2B303J	CHIP R 30K J 1/8W	
R4			RK73GB2A222J	CHIP R 2.2K J 1/10W	
R5			RK73FB2B272J	CHIP R 2.7K J 1/8W	
R6			RK73FB2B331J	CHIP R 330 J 1/8W	
R7,8			RK73FB2B752J	CHIP R 7.5K J 1/8W	
R9			RK73FB2B272J	CHIP R 2.7K J 1/8W	
R10			RK73FB2B331J	CHIP R 330 J 1/8W	
R11			R92-3041-05	CHIP R 11K D 1/10W	
R12			RK73FB2B303J	CHIP R 30K J 1/8W	
R13			R92-3044-05	CHIP R 18K D 1/10W	
R14			RK73GB2A472J	CHIP R 4.7K J 1/10W	
R16			RK73GB2A123J	CHIP R 12K J 1/10W	
R17			RK73GB2A133J	CHIP R 13K J 1/10W	
R18			RK73GB2A472J	CHIP R 4.7K J 1/10W	
R19,20			RK73GB2A123J	CHIP R 12K J 1/10W	
R21			RK73GB2A432J	CHIP R 4.3K J 1/10W	
R22			RK73GB2A133J	CHIP R 13K J 1/10W	
R23,24			RK73GB2A104J	CHIP R 100K J 1/10W	
R25			RK73GB2A102J	CHIP R 1.0K J 1/10W	
R26			RK73GB2A104J	CHIP R 100K J 1/10W	
R27			RK73GB2A102J	CHIP R 1.0K J 1/10W	
R28			RK73GB2A103J	CHIP R 10K J 1/10W	
R29			RK73GB2A133J	CHIP R 13K J 1/10W	
R30			RK73GB2A102J	CHIP R 1.0K J 1/10W	
R31			RK73GB2A472J	CHIP R 4.7K J 1/10W	
R32			RK73GB2A103J	CHIP R 10K J 1/10W	
R33			RK73GB2A104J	CHIP R 100K J 1/10W	
R34			RK73GB2A183J	CHIP R 18K J 1/10W	
R35			RK73GB2A102J	CHIP R 1.0K J 1/10W	
R36			RK73GB2A163J	CHIP R 16K J 1/10W	
R37			RK73GB2A102J	CHIP R 1.0K J 1/10W	
R39-41			RK73GB2A103J	CHIP R 10K J 1/10W	
R42,43			RK73GB2A104J	CHIP R 100K J 1/10W	
R45			RK73GB2A103J	CHIP R 10K J 1/10W	
R46			RK73GB2A4R7J	CHIP R 4.7 J 1/10W	
R47			RK73GB2A104J	CHIP R 100K J 1/10W	
R48			RK73GB2A102J	CHIP R 1.0K J 1/10W	
R49			RK73GB2A104J	CHIP R 100K J 1/10W	
R50			RK73GB2A102J	CHIP R 1.0K J 1/10W	
R51			RK73GB2A103J	CHIP R 10K J 1/10W	
R52			RK73GB2A104J	CHIP R 100K J 1/10W	
R53			RK73GB2A473J	CHIP R 47K J 1/10W	
R55			RK73GB2A103J	CHIP R 10K J 1/10W	
R56			RK73GB2A223J	CHIP R 22K J 1/10W	

E : Europe K : North America
M : Other Areas W : Without Europe

K : KDC-X969
M1 : KDC-9023R
E1 : KDC-PSW9524

△ Indicates safety critical components.

PARTS LIST

* New parts

Parts without **Parts No.** are not supplied.

Les articles non mentionnes dans le **Parts No.** ne sont pas fournis.

Teile ohne **Parts No.** werden nicht geliefert.

CD PLAYER UNIT (X32-5440-00)

Ref. No.	A d d	N e w	Parts No.	Description	Desti- nation	Ref. No.	A d d	N e w	Parts No.	Description	Desti- nation
R57			RK73GB2A472J	CHIP R 4.7K J 1/10W		24			D13-2153-04	GEAR	
R58			RK73GB2A101J	CHIP R 100 J 1/10W		25			D13-2154-04	GEAR	
R59			RK73GB2A164J	CHIP R 160K J 1/10W		26			D13-2155-04	WORM	
R60,61			RK73GB2A101J	CHIP R 100 J 1/10W		27			D13-2156-14	GEAR	
R62,63			RK73GB2A302J	CHIP R 3.0K J 1/10W		28			D13-2157-04	GEAR	
R64-66			RK73GB2A101J	CHIP R 100 J 1/10W		29			D13-2158-04	GEAR	
R67			RK73GB2A682J	CHIP R 6.8K J 1/10W		30			D13-2168-04	GEAR	
R68			RK73GB2A101J	CHIP R 100 J 1/10W		31			D13-2171-04	GEAR	
R69			RK73GB2A333J	CHIP R 33K J 1/10W		32			D13-2172-03	RACK (GEAR)	
R70			RK73GB2A103J	CHIP R 10K J 1/10W		33			D14-0759-04	ROLLER	
R71,72			RK73GB2A101J	CHIP R 100 J 1/10W		35			D21-2382-04	SHAFT	
R73			RK73GB2A241J	CHIP R 240 J 1/10W		36			D23-0954-04	RETAINER	
R74			RK73GB2A104J	CHIP R 100K J 1/10W		37			D39-0246-05	DAMPER	
R76			RK73GB2A101J	CHIP R 100 J 1/10W		38			G01-3072-04	EXTENSION SPRING	
R77			RK73GB2A102J	CHIP R 1.0K J 1/10W		39			G01-3073-04	TORSION COIL SPRING	
R78			RK73GB2A104J	CHIP R 100K J 1/10W		40			G01-3074-04	EXTENSION SPRING	
W1			R92-1252-05	CHIP R 0 OHM J 1/16W		41			G01-3075-04	EXTENSION SPRING	
S1,2			S68-0863-05	PUSH SWITCH		42			G01-3076-04	EXTENSION SPRING	
S3			S68-0862-05	PUSH SWITCH		43			G01-3077-04	EXTENSION SPRING	
D1			DAP202U	DIODE		44			G02-1399-04	FLAT SPRING	
D2			M1F60	DIODE		45			G02-1408-04	FLAT SPRING	
IC1			TAR5S33	ANALOGUE IC		51			J21-9676-22	MOUNTING HARDWARE	
IC2			NJM4580V	ANALOGUE IC		52			J21-9677-02	MOUNTING HARDWARE	
IC4			BA5824FP	ANALOGUE IC		53			J21-9678-03	MOUNTING HARDWARE	
IC5			UPC3025	ANALOGUE IC		55			J90-1001-11	GUIDE	
IC6			L88MS33T	ANALOGUE IC		56			J90-1023-03	GUIDE	
IC7		*	703030BYGC-J02	MI-COM IC		A			N09-4460-05	TAPTITE SCREW (OVAL P TAPTIT)	
IC8			TC74HCT7007AF	MOS-IC		B			N09-4472-05	MACHINE SCREW (M1.7X8.5)	
IC9			UPD61002GC-E01	MOS-IC		C			N09-6004-05	MACHINE SCREW (M1.7X2.5 IB-L)	
IC10			TC7SHU04FU	MOS-IC		E			N09-6007-05	MACHINE SCREW (PAN M2X2)	
IC11			UPD63760GJ	MOS-IC		F			N09-6051-05	TAPTITE SCREW (BIND P 2X5)	
IC12			HD74LV14AT	MOS-IC		G			N19-2163-04	FLAT WASHER	
IC13			IS41LV16257	DRAM IC		H			N39-2020-46	PAN HEAD MACHIN SCREW	
Q1			DTA143XUA	DIGITAL TRANSISTOR		J			N09-6108-05	MACHINE SCREW (M2*3.5TYPE3)	
Q2,3			DTC124EUA	DIGITAL TRANSISTOR		DM1			T42-1066-04	DC MOTOR ASSY (SP)	
Q4			MCH6101	TRANSISTOR		DM2			T42-1067-04	DC MOTOR ASSY (LO)	
Q5			DTA143EUA	DIGITAL TRANSISTOR		DPU1			X93-2010-00	OPTICAL PICKUP ASSY	
CD MECHANISM ASSY (X92-4710-01)											
2	1B		A10-4827-12	CHASSIS							
5	1B		D10-4576-33	ARM ASSY							
8	2A		D10-4579-03	LEVER ASSY							
10	3A		D10-4581-13	ARM							
11	2A		D10-4582-13	ARM							
12	3A		D10-4583-03	ARM							
13	3A		D10-4584-03	ARM							
14	3B		D10-4585-03	ARM							
15	2A		D10-4586-13	SLIDER							
16	3B		D10-4587-22	SLIDER							
17	3B	*	D10-4588-13	SLIDER							
18	3B		D10-4595-04	ARM							
19	3B		D10-4596-14	ARM							
22	2A		D13-2151-04	GEAR							
23	2B		D13-2152-04	GEAR							

E : Europe K : North America
M : Other Areas W : Without Europe

K : KDC-X969
M1 : KDC-9023R
E1 : KDC-PSW9524

△ Indicates safety critical components.

SPECIFICATIONS

		KDC-9023R	KDC-PSW9524	KDC-X969
FM	Frequency Range (Frequency step)	87.5MHz~108.0MHz (50kHz)	87.5MHz~108.0MHz (50kHz)	87.9MHz~107.9MHz (200kHz)
	Channel Space Selection	-	-	50kHz/200kHz
	Usable Sensitivity (S/N 26dB)	0.7μV/75Ω	0.7μV/75Ω	-
	Usable Sensitivity (S/N 30dB)	-	-	9.3dBf (0.8μV/75Ω)
	Quieting Sensitivity (S/N 46dB)	1.6μV/75Ω	1.6μV/75Ω	-
	Quieting Sensitivity (S/N 50dB)	-	-	15.2dBf (1.6μV/75Ω)
	Frequency Response (±3.0dB)	30Hz~15kHz	30Hz~15kHz	30Hz~15kHz
	S/N	65dB (MONO)	65dB (MONO)	70dB (MONO)
	Selectivity (DIN)	≥ 80dB (±400kHz)	≥ 80dB (±400kHz)	-
	Selectivity	-	-	≥ 80dB (±400kHz)
Stereo Separation	35dB (1kHz)	35dB (1kHz)	40dB (1kHz)	
AM (MW)	Frequency Range (Frequency step)	531kHz~1611kHz (9kHz)	531kHz~1611kHz (9kHz)	530kHz~1700kHz (10kHz)
	Channel Space Selection	-	-	9kHz/10kHz
	Usable Sensitivity (S/N 20dB)	25μV	25μV	28dBμ (25μV)
LW	Frequency Range	153kHz~281kHz	153kHz~281kHz	-
	Usable Sensitivity (S/N 20dB)	45μV	45μV	-
CD	Laser Diode	GaAlAs (λ=780nm)	GaAlAs (λ=780nm)	GaAlAs (λ=780nm)
	Digital Filter (D/A)	8 Times Over Sampling	8 Times Over Sampling	8 Times Over Sampling
	D/A Converter	1 Bit	1 Bit	1 Bit
	Spindle Speed (CD-DA) (MP3) (WMA)	1000~400rpm (CLV. 2 times)	1000~400rpm (CLV. 2 times)	1000~400rpm (CLV. 2 times)
	Wow & Flutter	Below Measurable Limit	Below Measurable Limit	Below Measurable Limit
	Frequency Response	10Hz~20kHz (±1dB)	10Hz~20kHz (±1dB)	10Hz~20kHz (±1dB)
	Total Harmonic Distortion	0.01% (1kHz)	0.01% (1kHz)	0.01% (1kHz)
	S/N Ratio	105dB (1kHz)	105dB (1kHz)	105dB (1kHz)
	Dynamic Range	93dB	93dB	93dB
	Channel Separation	95dB	95dB	95dB
	MP3 Decode	Compliant with MPEG-1.0/2.0/2.5 Audio Layer-3	Compliant with MPEG-1.0/2.0/2.5 Audio Layer-3	Compliant with MPEG-1.0/2.0/2.5 Audio Layer-3
	WMA Decode	Compliant with Windows Media Audio 8	Compliant with Windows Media Audio 8	Compliant with Windows Media Audio 8
Preout Level/Load (Unbalanced)		500mV/10kΩ (CD/CD-CH)	500mV/10kΩ (CD/CD-CH)	500mV/10kΩ (CD/CD-CH)
Preout Impedance		80Ω	80Ω	80Ω
AUX Input	Frequency Response	20Hz~20kHz±1dB	-	20Hz~20kHz±1dB
	Input Maximum Voltage	1200mV	-	1200mV
	Input impedance	100kΩ	-	100kΩ
Amplifier	Maximum Power	50Wx4	50Wx4	50Wx4
	Full Bandwidth Power (at less than 1% THD)	22Wx4	-	22Wx4
	PWR DIN45324, +B=14.4V	-	30Wx4	-
Tone	Bass	100Hz±10dB	100Hz±10dB	100Hz±10dB
	Middle	1kHz±10dB	1kHz±10dB	1kHz±10dB
	Treble	10kHz±10dB	10kHz±10dB	10kHz±10dB
General	Operating Voltage (11V~16V allowable)	14.4V	14.4V	14.4V
	Current Consumption	10A	10A	10A
	Installation Size (WxHxD)	178x50x165 (mm)	178x50x165 (mm)	178x50x165 (mm) 7x1-15/16x6-1/2 (in)
	Weight	1.70kg	1.70kg	3.75lbs (1.70kg)

KENWOOD follows a policy of continuous advancements in development. For this reason specifications may be changed without notice.

KENWOOD CORPORATION

2967-3, Ishikawa-machi, Hachioji-shi, Tokyo 192-8525, Japan

KENWOOD USA CORPORATION
P.O. BOX 22745, 2201 East Dominguez Street, Long Beach, CA90801-5745, U.S.A.

KENWOOD ELECTRONICS CANADA INC.
6070 Kestrel Road, Mississauga, Ontario, Canada L5T 1S8

KENWOOD ELECTRONICS LATIN AMERICA S.A.
P.O. Box 55-2791 Paillilla, Plaza Credicorp Bank Panama,
Piso 9, Oficina 901, Calle 50, Panama, Rep. de Panama

KENWOOD ELECTRONICS BRASIL LTDA.
Alameda Ministro Rocha Azevedo No. 456,
Edifício Jaú, 10o Andar, Cerqueira César, Cep 0140-001,
São Paulo-SP-Brasil

KENWOOD ELECTRONICS UK LIMITED
Kenwood House, Dwight Road, Watford, Herts, WD18 9EB, United Kingdom

KENWOOD ELECTRONICS DEUTSCHLAND GMBH
Rembrücker-Str. 15, 63150 Heusenstamm, Germany

KENWOOD ELECTRONICS FRANCE S.A.
13, Boulevard Ney, 75018 Paris, France

KENWOOD ELECTRONICS BELGIUM N.V.
Leuvensesteenweg 248 J, 1800 Vilvoorde, Belgium

KENWOOD ELECTRONICS ITALIA S.p.A.
Via G. Sirtori 7/9, 20129 Milano, Italy

KENWOOD IBÉRICA S.A.
Bolivia, 239-08020 Barcelona, Spain

KENWOOD ELECTRONICS AUSTRALIA PTY. LTD. (A.C.N. 001 499 074)
16 Giffnock Avenue, Centrecourt Estate, North Ryde,
N.S.W. 2113, Australia

KENWOOD ELECTRONICS (HONG KONG) LTD.
Unit 3712-3724, Level 37, Tower 1, Metroplaza, 223 Hing Fong Road, Kwai Fong, N.T.,
Hong Kong

KENWOOD ELECTRONICS GULF FZE
P.O. Box 61318, Jebel Ali, Dubai, U.A.E.

KENWOOD ELECTRONICS (THAILAND) CO., LTD.
2019 New Pechburi Road, Bangkok, Huaykwang, Bangkok, 10320 Thailand

KENWOOD ELECTRONICS SINGAPORE PTE. LTD.
1 Genting Lane, #07-00, Kenwood Building, Singapore, 349544

KENWOOD ELECTRONICS (MALAYSIA) SDN BHD
#4.01 Level 4, Wisma Academy Lot 4A, Jalan 19/1, 46300 Petaling Jaya, Selangor Darul Ehsan,
Malaysia