

# EXPLODED VIEW

## DISPENSER RELATED PARTS

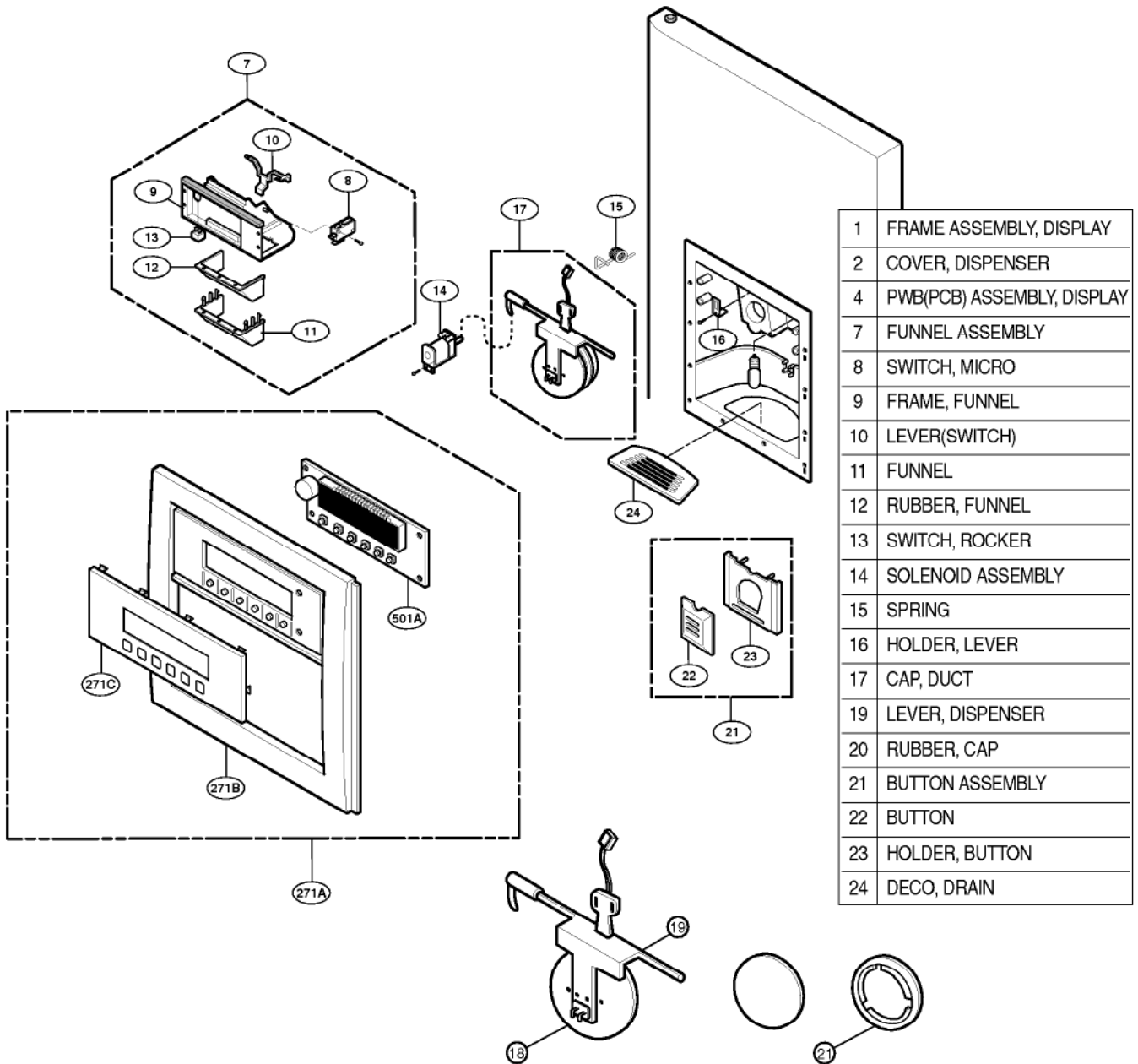

< 17 Cap Assembly, Duct Detailed Drawings >





# EXPLODED VIEW

## FREEZER COMPARTMENT

\* : Optional part

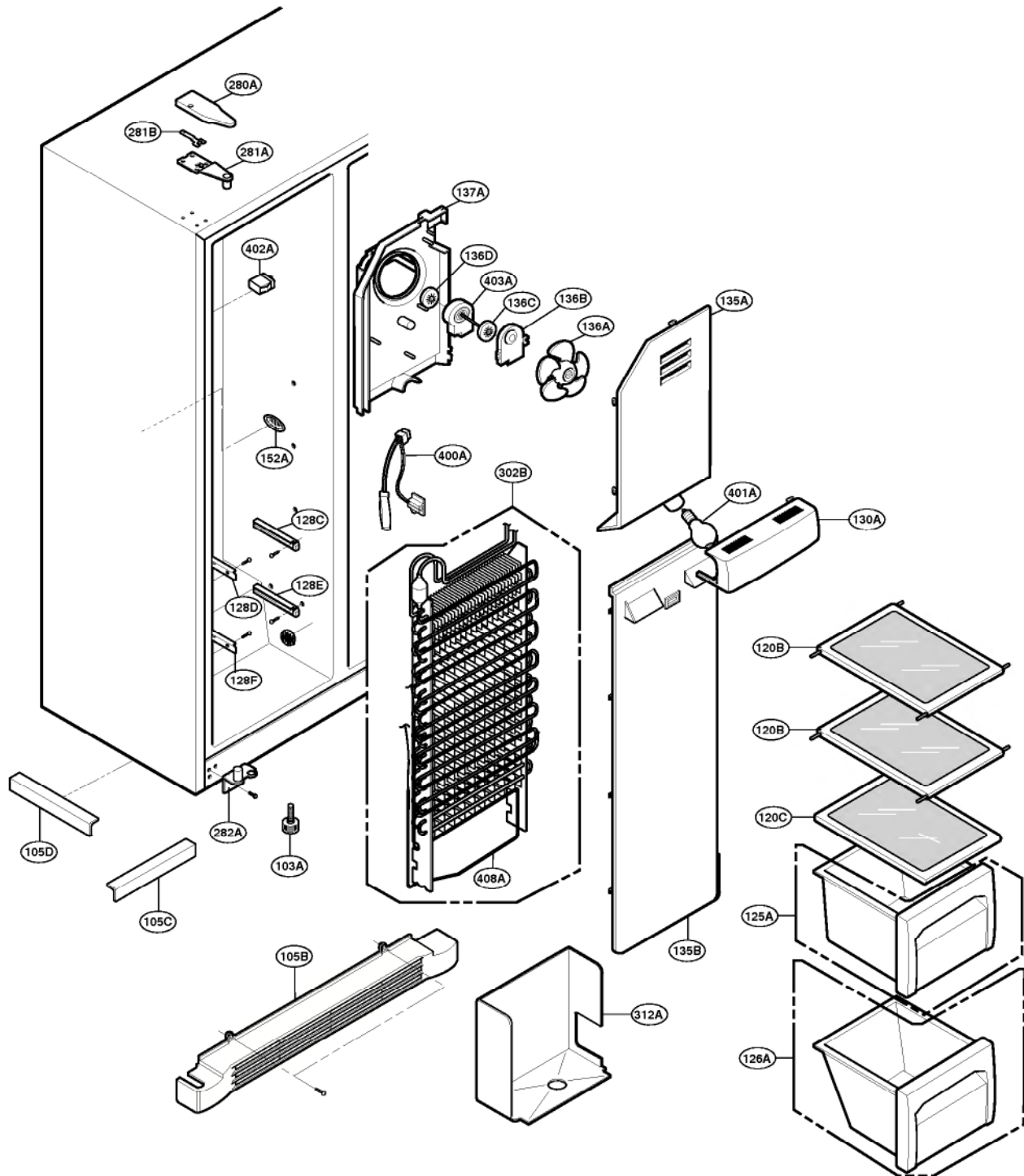

# EXPLODED VIEW

## FREEZER COMPARTMENT

\* : Optional part

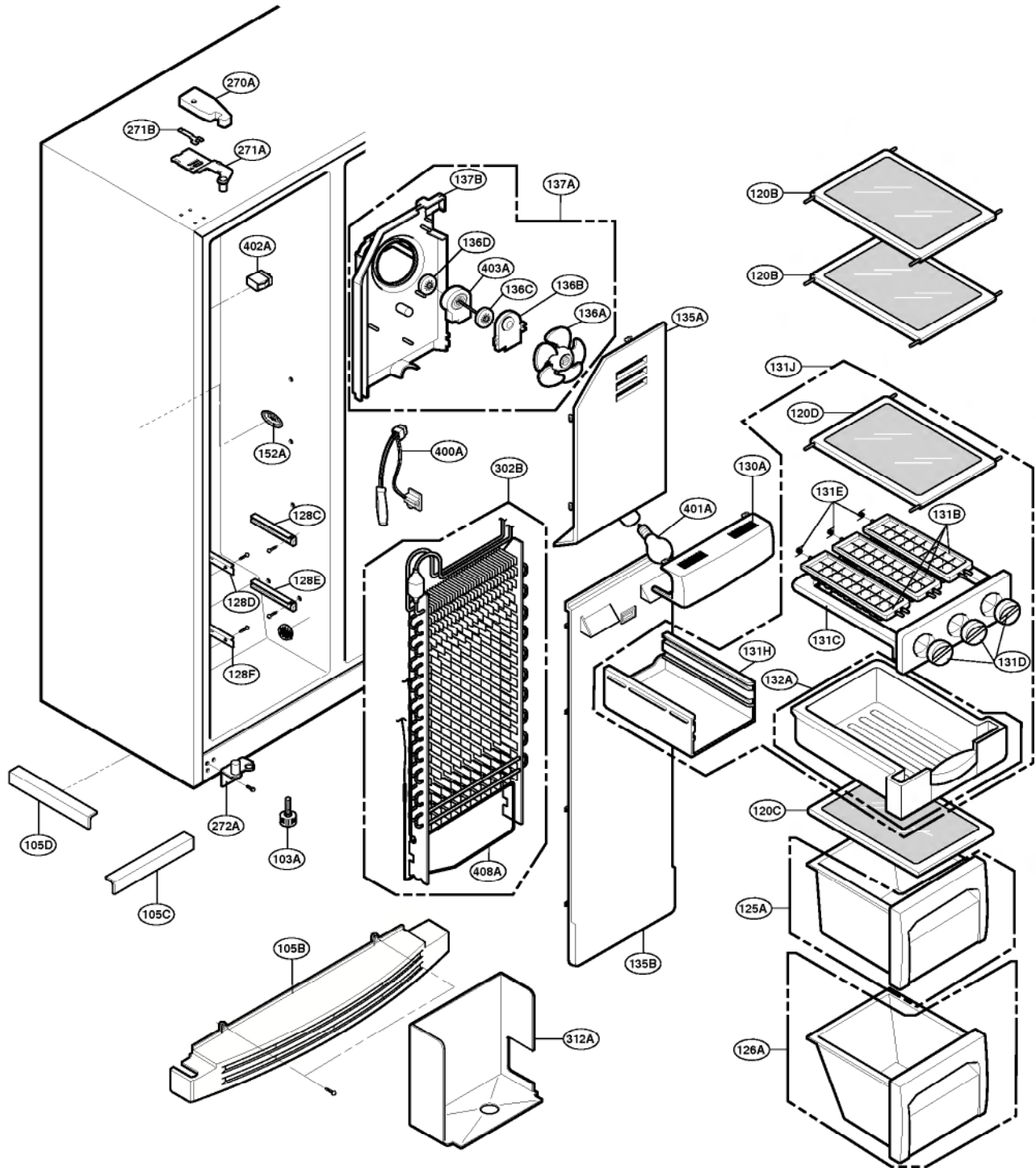





# EXPLODED VIEW

## MACHINE COMPARTMENT

\* : Optional part

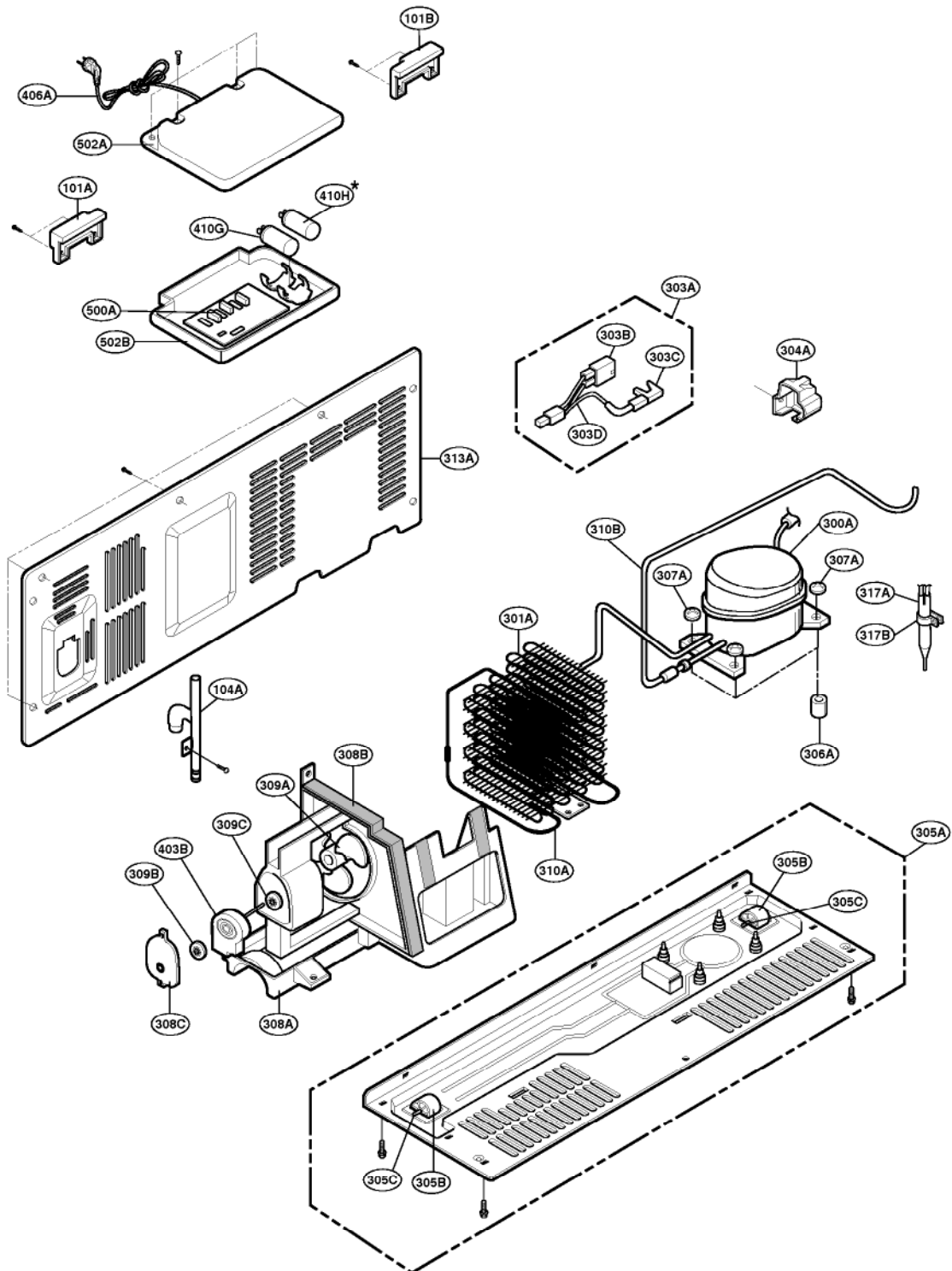



# EXPLODED VIEW

## DISPENSER PART

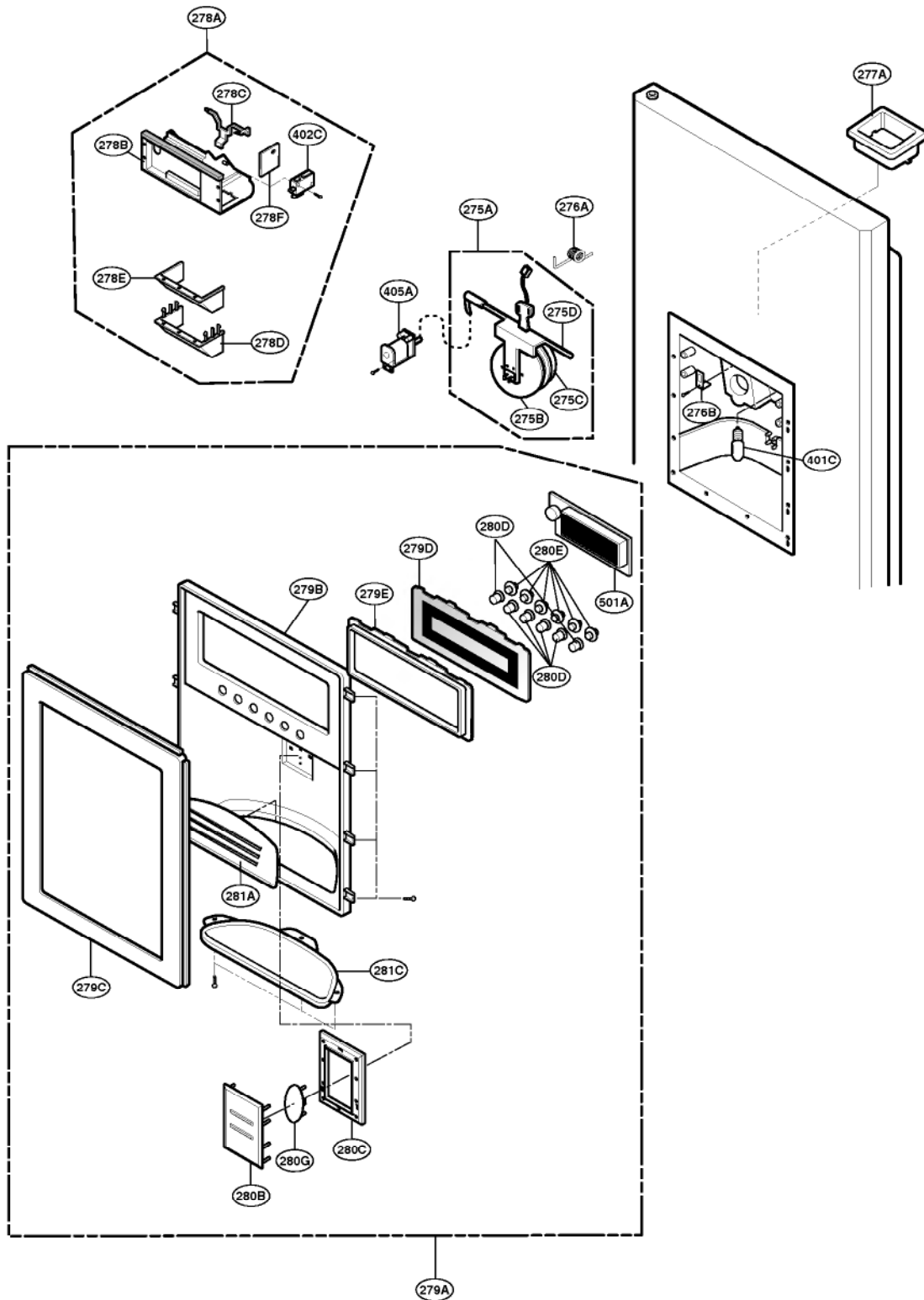

# EXPLODED VIEW

## LCD TV PART

