



DISHWASHER

SERVICE MANUAL

NOTE

BEFORE SERVICING THE UNIT, PLEASE READ THIS MANUAL CAREFULLY FOR SAFETY AND CORRECT SERVICES.

MODEL : LD-2120W(M)HU
LD-2140W(M)HU
LD-2143W(T)HU

CONTENTS

1. CAUTION.....	4
2. SPECIFICATIONS	5
3. FEATURES & TECHNICAL EXPLANATION	6
4. PARTS NAME	10
5. WIRING DIAGRAM	11
6. PROGRAM CHART (SCHEMATIC DIAGRAM).....	12
7. HOW TO DISASSEMBLE	13
8. TROUBLE SHOOTING METHODS.....	23
A. TROUBLE SHOOTING ACCORDING TO DISPLAYED ERROR MESSAGE	23
B. TROUBLE DIAGNOSES AND REPAIR BY SYMPTOM.....	25
9. INSTALLATION INSTRUCTION	29
10. EXPLODED VIEW	33

CAUTION !

- DISCONNECT POWER CORD BEFORE SERVICING
- RECONNECT ALL GROUNDING DEVICES

IMPORTANT SAFETY NOTICE !

This service information is intended for individuals possessing adequate backgrounds of electrical, electronic and mechanical experience.

Any attempt to repair this appliance may result in personal injury and property damage.

The manufacturer or seller can not be responsible for the interpretation of this information, nor can it assume any liability in connection with its use.

2. SPECIFICATION

ITEM	SPECIFICATION
Rated Voltage / Frequency	AC 230V/50Hz
Installation	Built-under
Place Settings	12
Product Dimension(mm)	598(W) × 580(D) × 817(H)
Product Weight(Kg)	48
Door Colour	White / Silver / Titanium
Tub Material	Stainless Steel
Control	Electronic
Rated Power(Watt)	2,210
Heater Power(Watt)	2,100
Programs	212 series : 4 / 214 series : 5
Upper Rack Position	Adjustable
Lower Rack	50% Fold down
Water Consumption (ℓ)	15 (Eco)
Power Consumption (kWh)	1.05 (Eco)
Operating Time (min)	115(Except Drying):Eco
Fan Dry System	Yes
Delay Start Function	Yes
Auto-Off Power Switch	Yes
Process Monitor	No
Wash Level	5
Racks	Nylon Coating
Operating Water Pressure (Bar)	0.5 ~ 8

3. FEATURES & TECHNICAL EXPLANATION

3-1 New Technology Introduction

3-1-1. High Temperature Rinsing (LD-213/214 series only)

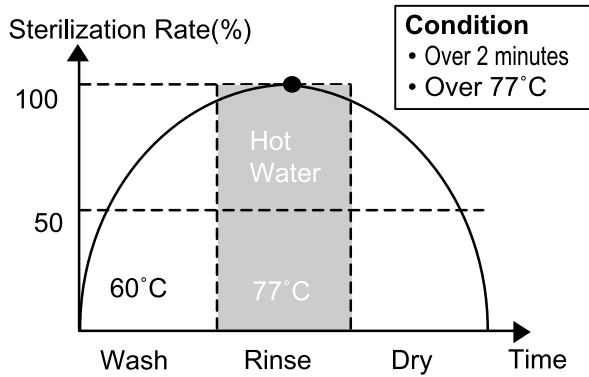

- During the high temp. Rinse course, water temperature in an dishwasher reaches 77°C, considerably higher than the average rinse temperature in conventional dishwashers(65°C). This is how Rinse 77°C can eliminate some bacteria such as salmonella.

3-1-2. Turbo Spray System

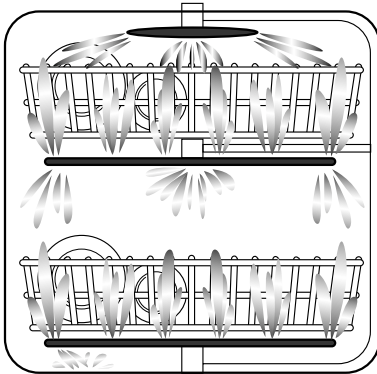

- Turbo Spray System is elaborately designed to achieve a more powerful and efficient wash. You can see the excellent 3 rotating spray arm with 5 directional waterjet.

3-2. Display Panel

3-2-1. LD-212 Series

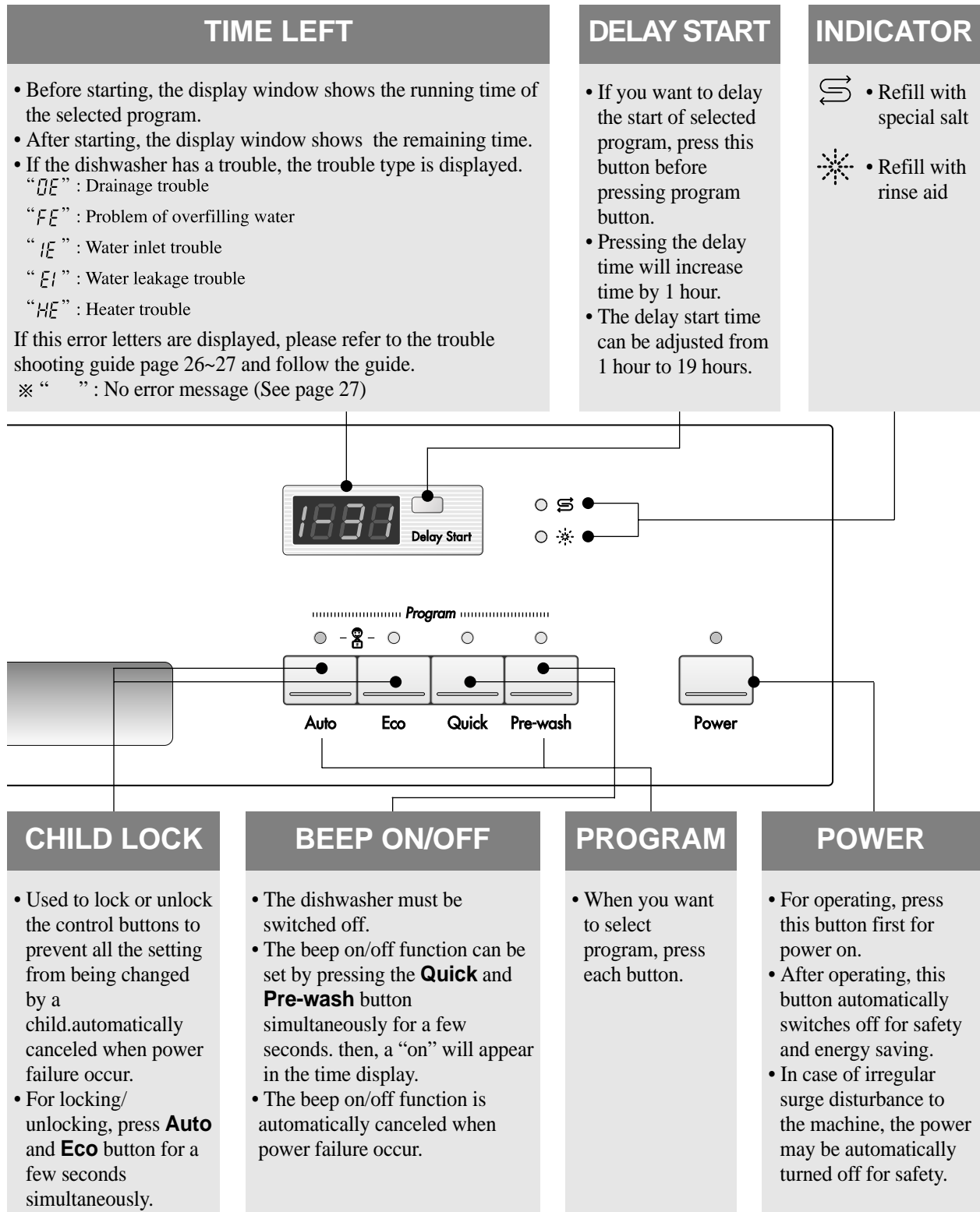

3-2-2. LD-214 Series

TIME LEFT	DELAY START	INDICATOR	POWER	
<ul style="list-style-type: none"> • Before starting, the display window shows the running time of the selected program. • After starting, the display window shows the remaining time. • If the dishwasher has a trouble, the trouble type is displayed. <ul style="list-style-type: none"> “DE” : Drainage trouble “FE” : Problem of overfilling water “IE” : Water inlet trouble “EI” : Water leakage trouble “HE” : Heater trouble <p>If this error letters are displayed, please refer to the trouble shooting guide page 26~27 and follow the guide.</p> <p>※ “Ld” : No error message (See page 27)</p>	<ul style="list-style-type: none"> • If you want to delay the start of selected program, press this button before pressing program button. • Pressing the delay time will increase time by 1 hour. • The delay start time can be adjusted from 1 hour to 19 hours. 	<ul style="list-style-type: none"> • Refill with special salt • Refill with rinse aid 	<ul style="list-style-type: none"> • For operating, press this button first for power on. • After operating, this button automatically switches off for safety and energy saving. • In case of irregular surge disturbance to the machine, the power may be automatically turned off for safety. 	
SPRAY INTENSITY	EXTRA HOT	CHILD LOCK	BEEP ON/OFF	PROGRAM
<ul style="list-style-type: none"> • With each press, the level of water jet is changed to “Strong-☉” and “Soft-☼” 	<ul style="list-style-type: none"> • When select Extra Hot function, the operating temperature will be up to 77℃. 	<ul style="list-style-type: none"> • Used to lock or unlock the control buttons to prevent all the setting from being changed by a child.automatically canceled when power failure occur. • For locking/ unlocking, press Intensive and Auto button for a few seconds simultaneously. 	<ul style="list-style-type: none"> • The dishwasher must be switched off. • The beep on/off function can be set by pressing the Quick and Pre-wash button simultaneously for a few seconds. then, a “on” will appear in the time display. • The beep on/off function is automatically canceled when power failure occur. 	<ul style="list-style-type: none"> • When you want to select program, press each button.

3.3 TEST MODE

CHECK PROGRAM(START IN THE STATE OF THE CLOSED DOOR)

BUTTON	The number of pushing button	DISPLAY	Load and Checking points	
Auto + Quick + POWER S/W	1 TIME	n : 0H	All LEDs are lighting	
Half Load KEY (Spray Intensity Key)	1 TIME	11 : 11	All LEDs are lighting	
Extra Hot KEY	1 TIME	12 : 22	All LEDs are lighting	
Intensive	1 TIME	13 : 33	All LEDs are lighting	
Auto KEY	1 TIME	14 : 44	All LEDs are lighting	
Eco KEY	1 TIME	15 : 55	All LEDs are lighting	
Quick KEY	1 TIME	16 : 66	All LEDs are lighting	
Pre-wash KEY	1 TIME	17 : 77	All LEDs are lighting	
Time Delay Key	1 TIME	n : 01	None	Salt Refill
	2 TIME	n : 02	Washing motor	Rinse Refill
	3 TIME	n : 03	Drain pump	Upper(Strong)
	4 TIME	Frequency	Inlet valve	Lower(Soft)
	5 TIME	n : 05	Dispenser	Extra Hot
	6 TIME	n : 06	Heater(for 10 sec.)	Intensive
	7 TIME	Temperature	Fan motor	Auto
	8 TIME	n : 08	Regeneration Valve	Eco
	9 TIME	n : 09	Lower Nozzle	Quick
	10 TIME	n : 0A	Upper Nozzle	Pre-wash
	11 TIME	n : 0b	Auto OFF S/W	

※ Micro S/W must be ON to operate HEATER

4. PARTS NAME

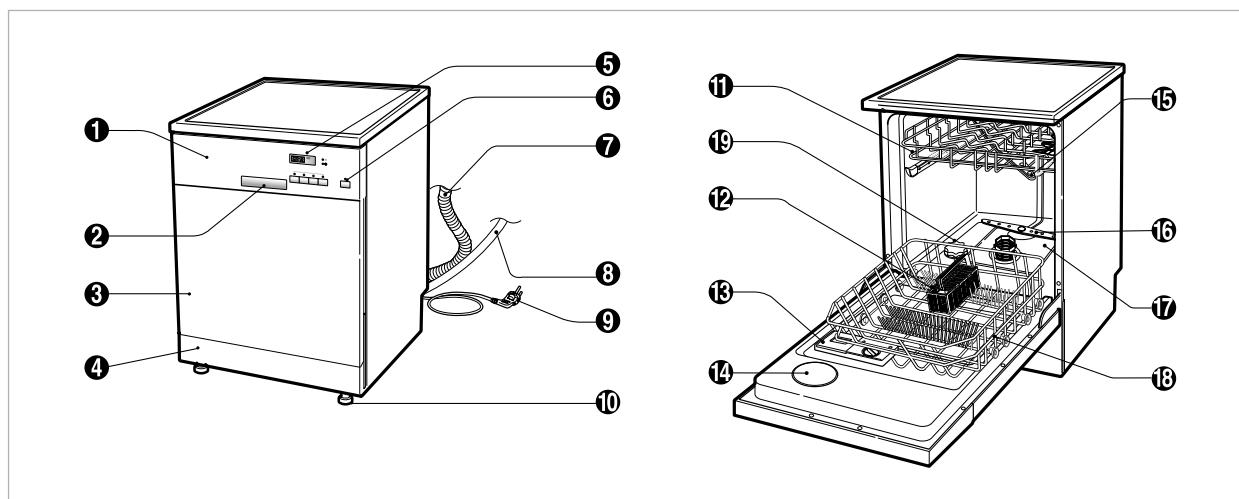

1. Control Panel
2. Door Handle
3. Front Cover
4. Lower Cover
5. Process Monitor
6. Power Switch
7. Drain hose
8. Inlet hose
9. Power Cord

10. Adjust Leg
11. Upper Rack
12. Cutlery Rack
13. Detergent & Rinse Aid Dispenser
14. Vapor Vent Cover
15. Upper Spray Arm
16. Lower Spray Arm
17. Filter ASM
18. Lower Rack
19. Salt Container Cap

Accessories



Funnel

※ The appearance and specifications may be varied without notice according to localities.

7. HOW TO DISASSEMBLE

BEFORE DISASSEMBLING THE DISHWASHER ;

- 1) Remove the plug from electric outlet to avoid electric shock.
- 2) Close the Water Tap(faucet).
- 3) Remove all dishes and items in the dishwasher.
- 4) Remove the Lower Rack and the Upper Rack.
- 5) In case of the water softner assembly model, open the water softner cap to flow out the water to sump and drain to avoid the floor wet.
- 6) If necessary, remove the inlet hose and drain hose to avoid the hose damages.
- 7) Prepare some towels to avoid floor wet by the water left in the dishwasher.

7-1. FULL DISASSEMBLE

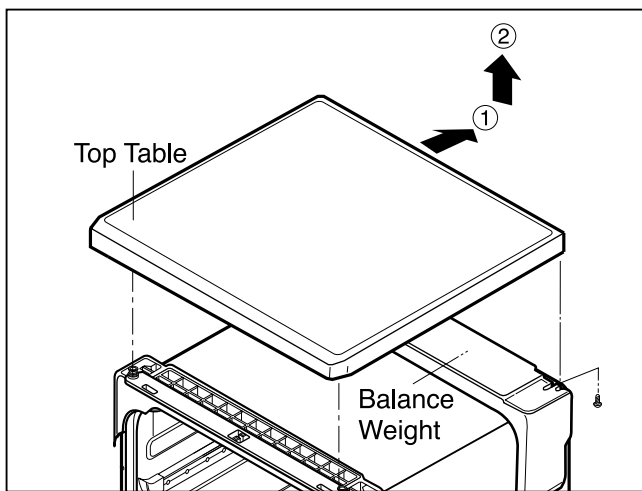

1. Top Table

- 1) Remove the rear 2 screws.
- 2) Pull and lift the top table.

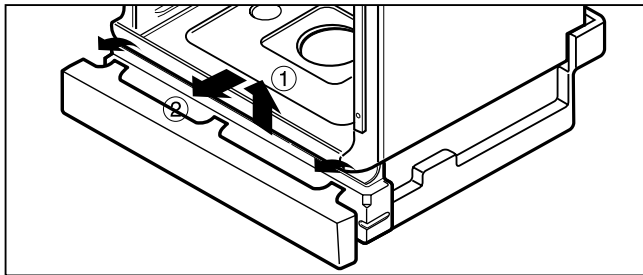

2. Low Cover

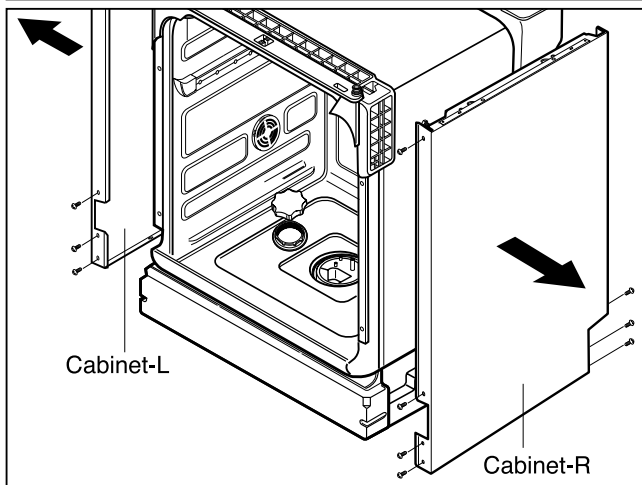

3. Cabinet-R/L

- 1) **Cabinet-R**
 - ① Remove front 4 screws.
 - ② Remove rear 3 screws.
- 2) **Cabinet-L**
 - ① Remove front 4 screws.
 - ② Remove rear 3 screws.

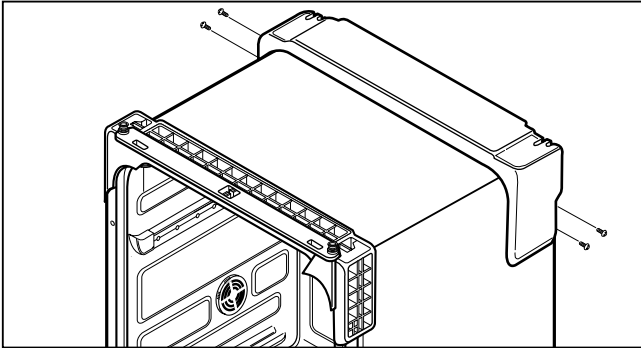

4. Balance weight

- 1) Remove side 4 screws.
- 2) Lift the balance weight.

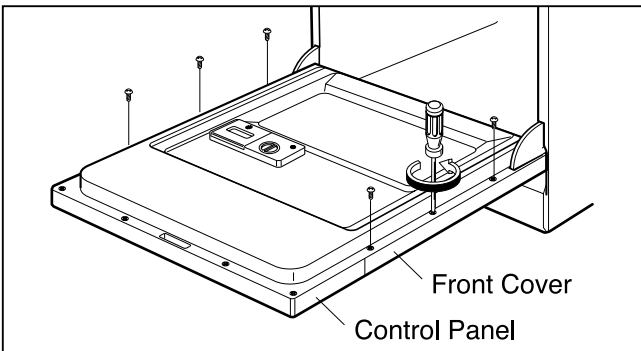

5. Door Assembly

1) Front Cover

- ① Open the door.
- ② Remove 6 screws(stainless).
- ③ Close the door slowly and remove front cover downwards.

2) Control Panel Assembly

- ① Open the door.
 - ② Remove 4 screws(stainless).
 - ③ Remove wire connection.
- Be sure the wiring should not be changed in reassembling.
- ④ Remove 3 screws for Latch assembly
 - ⑤ Remove 3 screws for Controller.

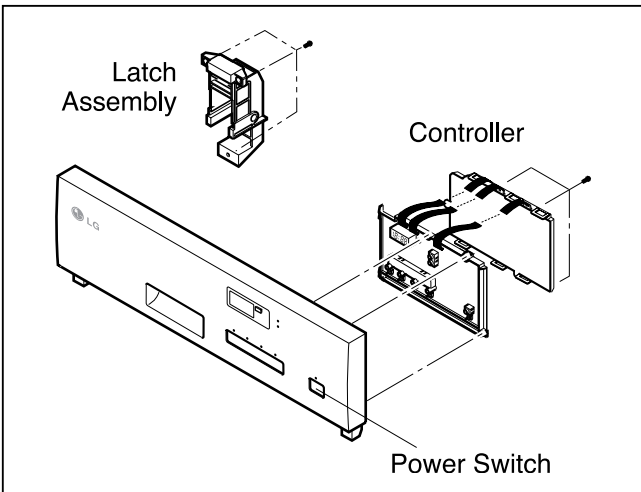

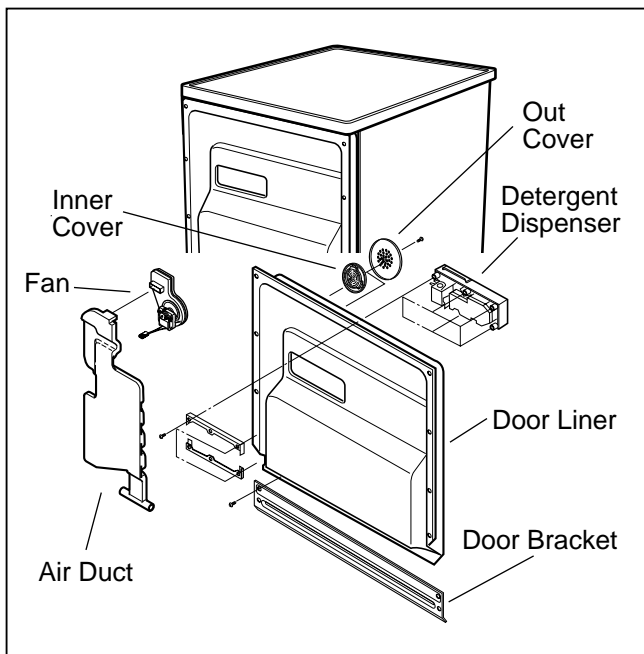

3) Fan

- ① Open the door.
- ② Remove the air duct.
- ③ Remove the wire connections.
- ④ Remove the outer cover by removing 1 screw.
- ⑤ Remove 2 fixing screws inside and turn the Inner Cover counterclockwise.

4) Detergent Dispenser

- ① Close the door.
- ② Remove the wire connections.
- ③ Remove 6 screws with brackets.

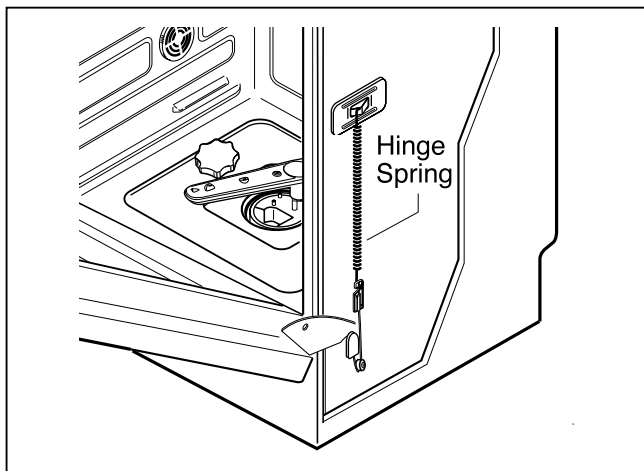

5) Door Spring (Right & Left)

- ① Push the Spring upwards and take it off from the Frame.
- Be careful not to be injured by the sharp edge of Tub.
- ② Take the Hinge Link off from the Hinge.

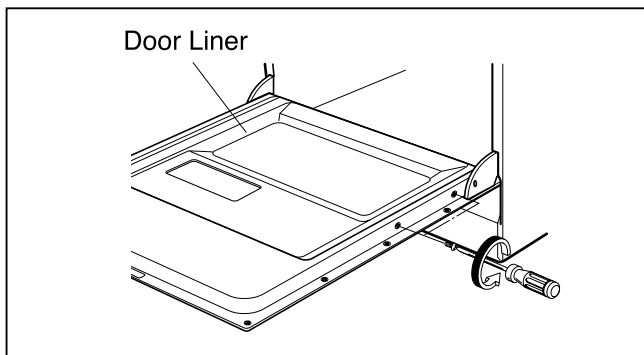

6) Door Liner

- ① Open the door.
 - ② Remove 4 screws.
- Do not use other screws for assembling.

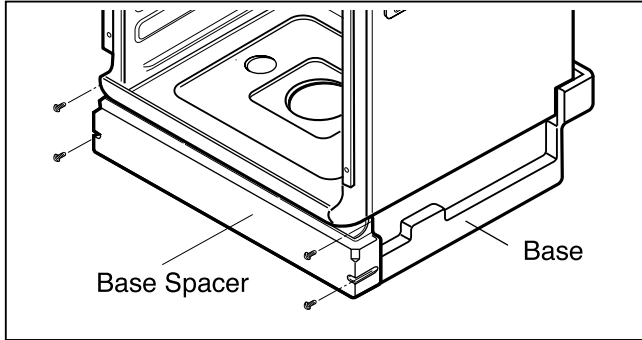

6. Base spacer

- ① Remove 4 screws.
- ② Lift the front side of dishwasher and pull the base spacer forward.

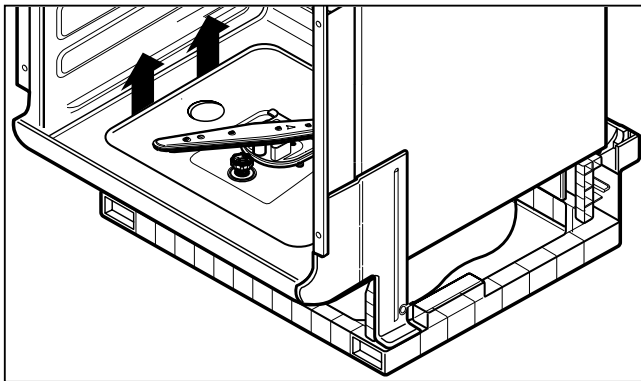

7. Tub assembly

1) Nozzle

- ① Pull up the nozzle.

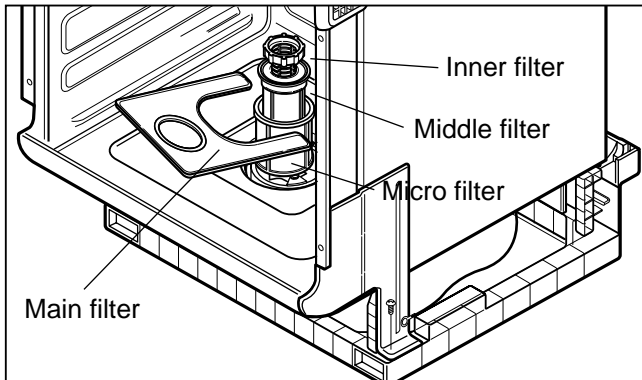

2) Filter Assembly

- ① Turn inner filter counterclockwise and lift inner filter and middle filter.

You can disassemble inner filter and middle filter by pulling opposite direction.

- ② Lift up main filter.
- ③ Lift up micro filter.

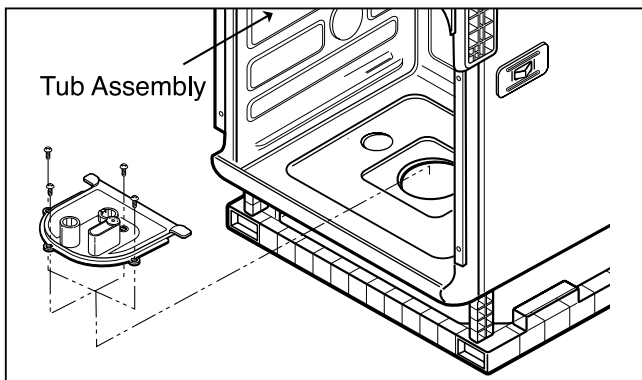

3) Nozzle Holder

- ① Disconnect the water guide
- ② Remove 4 screws and lift it up

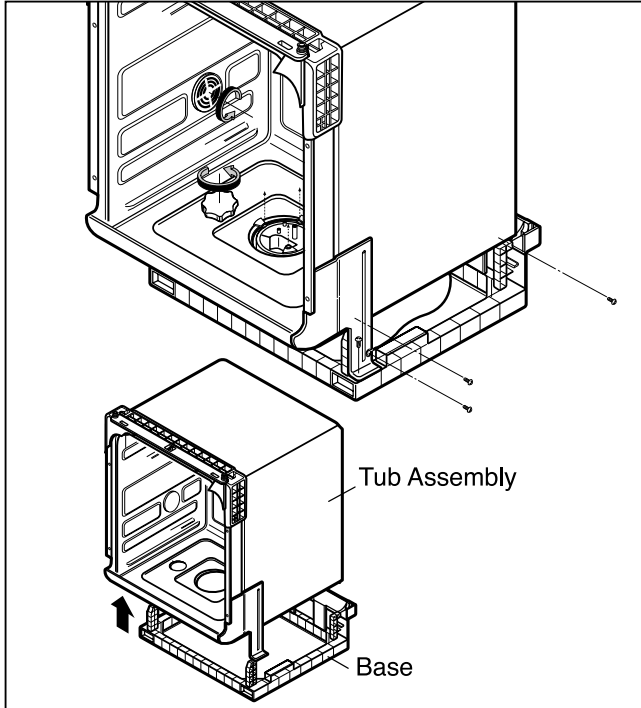

4) Tub

- ① Turn the air guide nut counter-clockwise.
(Special tool might be needed.)

Be careful the rubber packing of air guide assembly should not be lost.

- ② Turn the softner cap and nut counter-clockwise.
- ③ Remove 4 screws for sump holder .
- ④ Remove side 8 screws.
- ⑤ Remove 2 Earth screw of right side.
- ⑥ Lift tub assembly upward.
(Be sure water softner is not blocked.)

Be careful not to be injured or scratch floor by the sharp edge of tub.

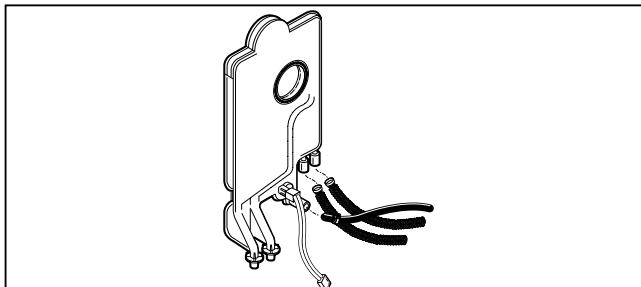

8. Air Guide Assembly

- ① Disconnect the wiring connection.
- ② Remove 3 hoses assembly.

Be careful the o-ring should not be lost.

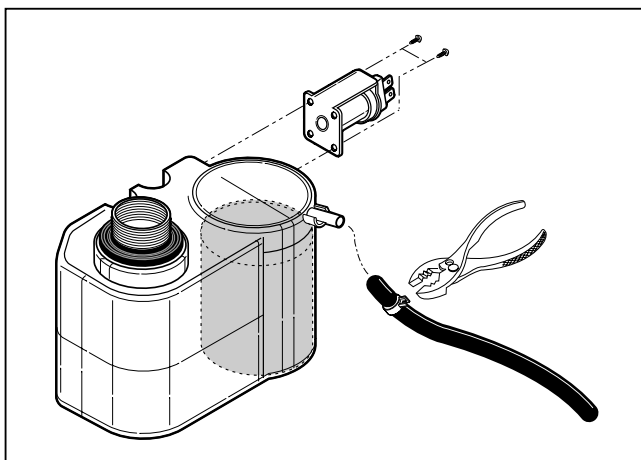

9. Water softner

- 1) Remove the hose assembly.
- 2) Lift it upward.

Be careful not to wet the floor by the water left in the water softner.

- 3) You can disassemble the regeneration valve by unscrew the 2 screw.

Be sure not to lost the spring and bobbin.

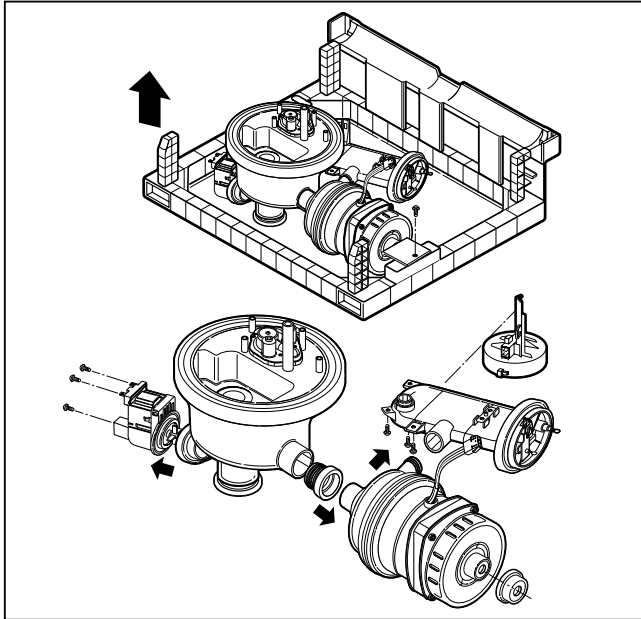

10. C-Base Assembly

- 1) Remove the screw which tighten washing motor and base.
- 2) Lift them upward.

Be careful not to wet the floor by the water left in the sump.

- 3) Pull out the float switch with pressing downward softly.(not on all models)
- 4) Detach the washing motor and heater assembly by pulling opposite direction to sump.
- 5) Remove the 3 screw for drain motor.

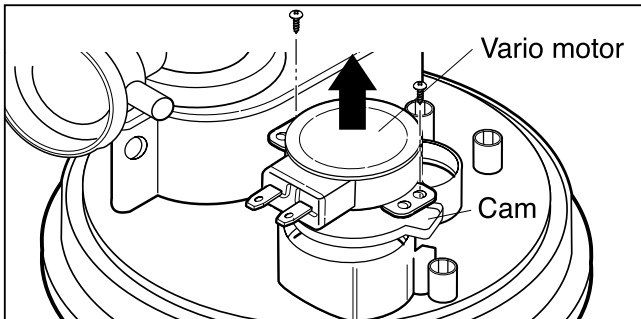

6) synchronous motor

- ① Remove the 2 screws.
 - ② Lift the cam upward.
- ※ Be careful not to install upside down.
(part number on the cam should face the motor.)

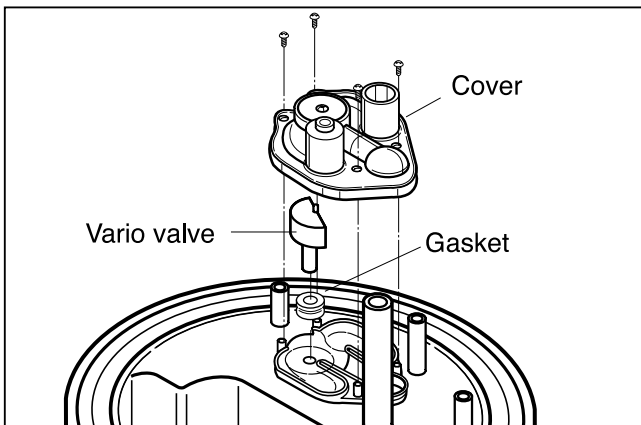

7) Vario valve

- ① Remove 4 screws and lift the cover upward.
- ② Lift the vario valve upward.

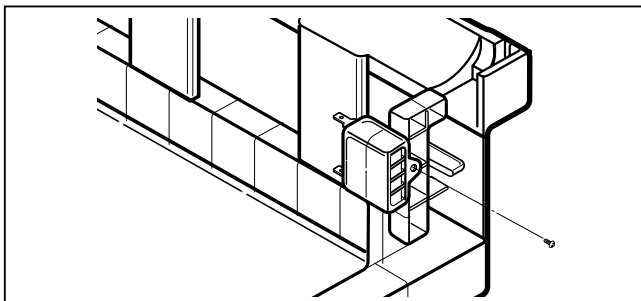

8) Capacitor

- ① Remove 1 screw.

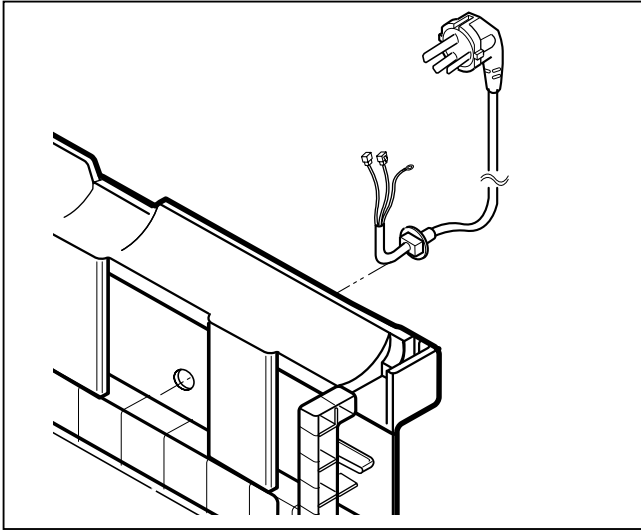

8) Power cord assembly

- ① Turn the power cord assembly 90° and take it off.

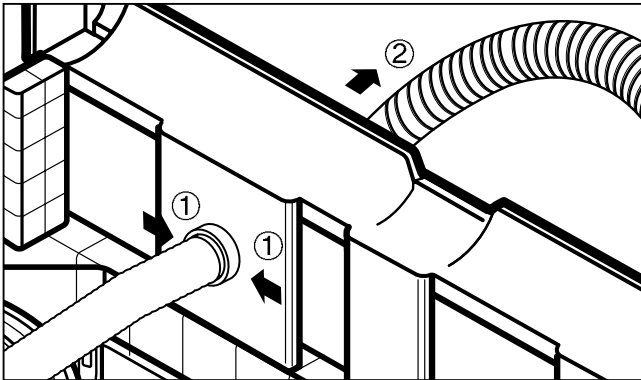

9) Aquastop(Not on all models)

- ① Press the holder hook as shown in figure.
- ② Pull the hose assembly.

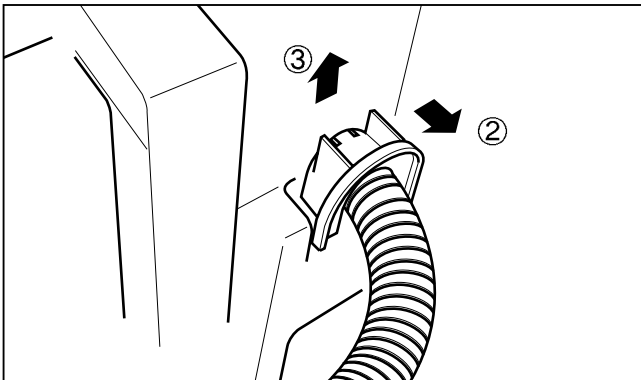

10) Drain Hose

- ① Press the rear side hook.
- ② Pull the holder forward.
- ③ Pull the holder upward.

7-2. DISASSEMBLE C-BASE ASSEMBLY

Be careful not to be injured by the sharp edge of tub.

1. Top Plate

- See 7-1. 1. (Page 16)

2. Low Cover

- See 7-1. 2. (Page 16)

3. Cabinet-R/L

- See 7-1. 3. (Page 16)

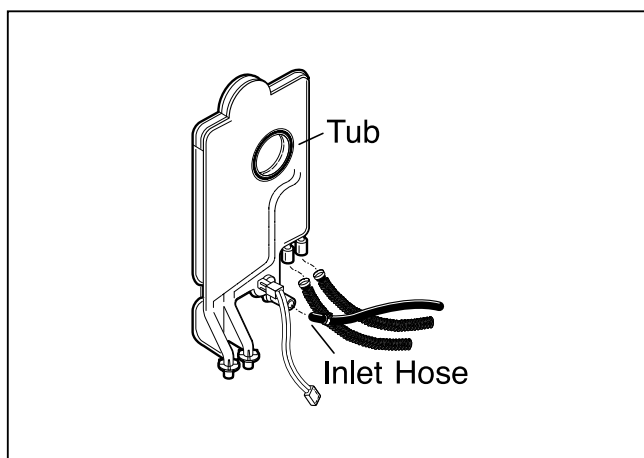

4. Air Guide

- ① Disconnect 3 hoses assembly.
- ※ You need not to unscrew the air guide nut.

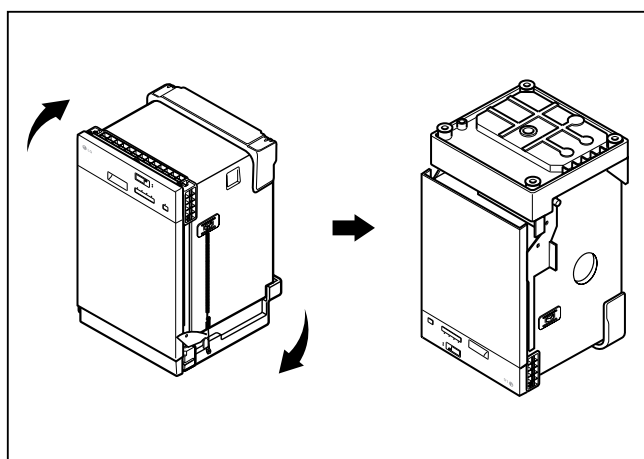

5. Put the Dishwasher upside down.

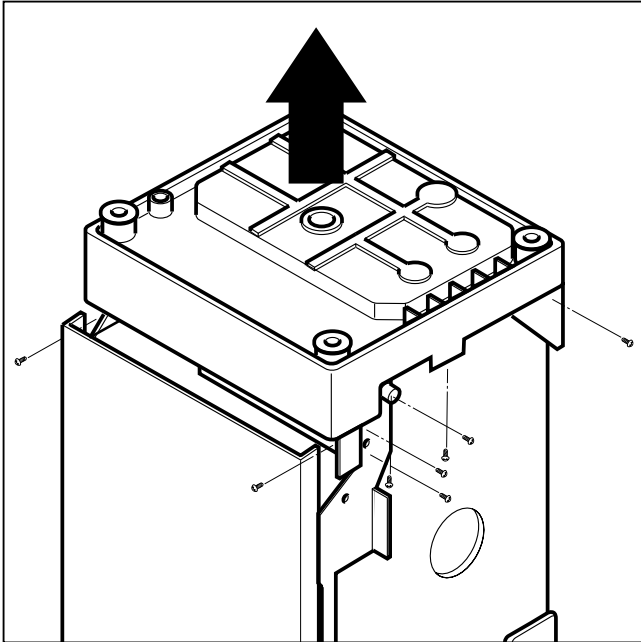

6. Remove the side screws

- 1) Remove side 8 screws.
- 2) Remove 2 Earth screws of right side.
- 3) Remove 1 motor bracket screw.
- 4) Lift base upward slightly.
(You can't lift up base perfectly because of some parts connecting to base.)

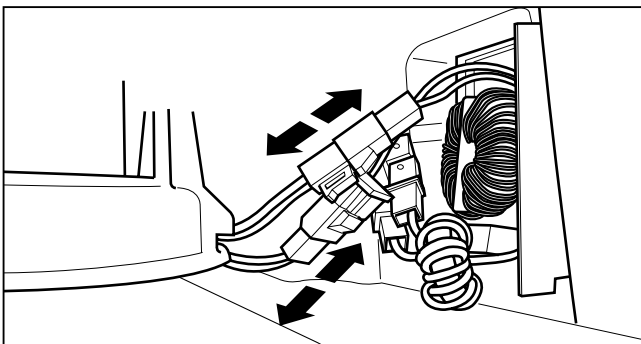

7. Disconnect the connecting points between tub and base

- 1) Disconnect noise filter.
(Not on all models)
- 2) Disconnect of powercord assembly.

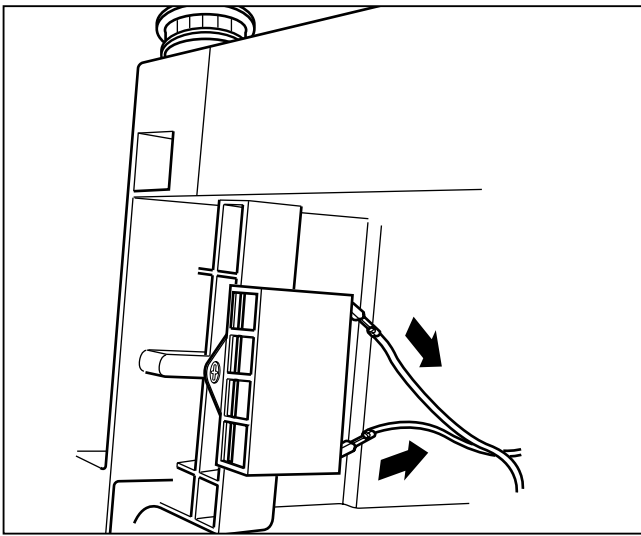

- 3) Disconnect wire from the capacitor.

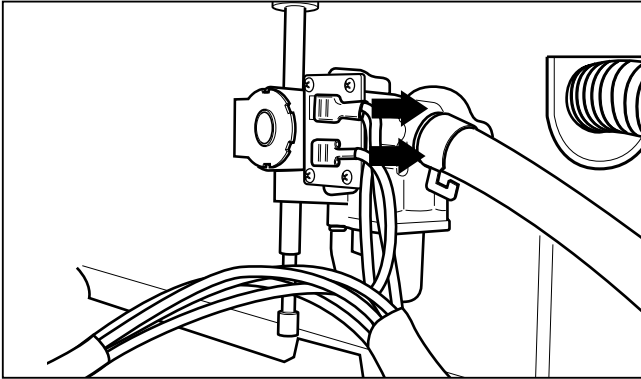

4) Disconnect wire from the inlet valve or Aquastop

※ Now, you can remove the base from the tub perfectly.

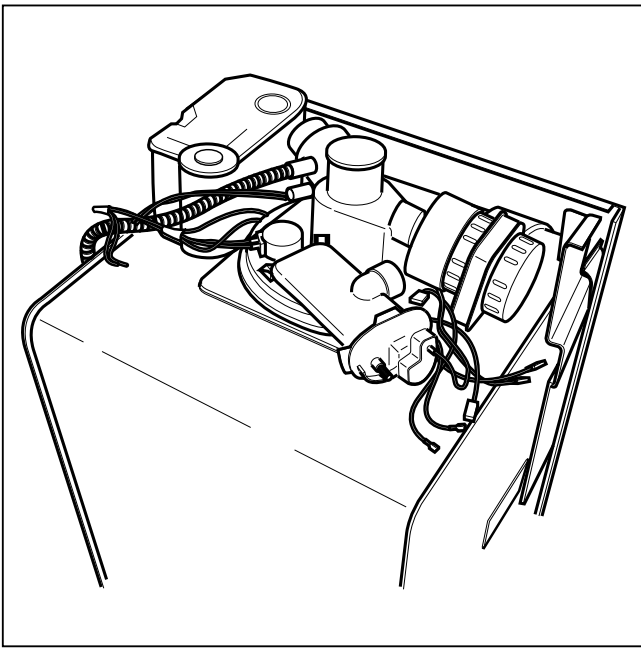

8. C-Base Assembly



※ You can repair the parts in the C-Base like heater case, washing pump, drain motor etc. you may refer to 7-1. 10. 2)~10) (Page 20~24)





※ Don't disassemble sump by 7-2.

If you want to disassemble the sump, follow 7-1.

8.TROUBLE SHOOTING METHODS

A. TROUBLE SHOOTING ACCORDING TO DISPLAYED ERROR MESSAGE

ERROR MESSAGE	POSSIBLE CAUSE FOR ERROR OCCURRENCE	REMEDY
<p>INLET ERROR</p>  <p>displayed</p> <p>Condition Not reached to the normal water level in spite of 10 min. water supply</p>	<ul style="list-style-type: none"> • The Water Tap is not opened. • The Inlet Hose is kinked. • The Filter of inlet valve clogged by impure water. • The Inlet Water Valve is normal ? • The water pressure is very low. (below 0.5 kgf/cm²) • Inlet valve is blocked by safety device for leakage sensing.(In case of Inlet Valve) 	<ul style="list-style-type: none"> • Open the Water Tap. • Repair the Inlet Hose. • a) Close the Water Tap. • b) Unscrew the Inlet Hose (Inlet Valve side) • c) Clean the Filter of Inlet Valve. • Replace or repair the Inlet Valve. • Check the water remain on the base. <ol style="list-style-type: none"> 1) Check the point of damages and repair or replace the related parts. 2) Disconnect the inlet hose to dishwasher to unlock the safety valve.
<p>DRAIN ERROR</p>  <p>displayed</p> <p>Condition Not fully drained out in spite of 5 min. drain operation</p>	<ul style="list-style-type: none"> • The Filter clogged. • The Drain Hose kinked or blocked. • The Drain Pump/Motor or circuit is troubled. 	<ul style="list-style-type: none"> • Clean the Filter. • Remove the cause of kink or block. • Replace the Drain Pump/Motor or repair the Circuit.
<p>LEAKAGE ERROR</p>  <p>displayed</p> <p>Condition The water level in Tub goes down during operation</p>	<ul style="list-style-type: none"> • Water leakage in Hose connections. • Water is leaked by damages. • Impeller of the washing Pump is worn away. • The Thermal Protector of the washing motor is functioned. 	<ul style="list-style-type: none"> • Replace the connections of Hose. • Check the point of damages and repair or replace the related parts. • Replace the washing pump. • Check the applied voltage.

ERROR MESSAGE	POSSIBLE CAUSE FOR ERROR OCCURRENCE	REMEDY
<p>EXCESS ERROR</p>  <p>displayed</p> <p>Condition</p> <p>Excessive water is supplied than normal water level.(Automatically drain Pump operated.)</p>	<ul style="list-style-type: none"> • The Inlet Valve is troubled. • The Air Break is troubled. • The Sensor Assembly is troubled. • The Controller is troubled. 	<ul style="list-style-type: none"> • Replace the Inlet Valve. • Replace the air breaker. • Replace the sensor assembly. • Repair or replace the Controller.
<p>THERMAL ERROR</p>  <p>displayed</p> <p>Condition</p> <p>The resistance of thermistor not normally out put.</p>	<ul style="list-style-type: none"> • The Circuit of thermistor is troubled. • Thermistor is troubled. • The Controller is troubled. 	<ul style="list-style-type: none"> • Repair the Circuit of thermistor. • Replace the Thermistor. • Repair or replace the Controller.
<p>HEATER ERROR</p>  <p>displayed</p> <p>Condition</p> <p>The water is not heated or the temperature in the Tub is overheated to over 95°C</p>	<ul style="list-style-type: none"> • The Circuit of Heater is troubled. • The Thermistor is troubled. • The Heater is shorted. • The Relay Circuit is troubled. 	<ul style="list-style-type: none"> • Repair the Circuit of Heater. • Replace the Thermistor. • Replace the Heater. • Repair the Relay Circuit..
<p>COOL DRY</p>  <p>displayed</p> <p>Condition</p> <p>No error message</p>	<ul style="list-style-type: none"> • This process is not part of the program. At this time, the fan will operate for a few more minutes to diminish any remaining moisture. If you want, you can now open and unload the dishwasher. Otherwise the dishwasher automatically switches off for safety and energy saving later. 	

B. TROUBLE DIAGNOSES AND REPAIR BY SYMPTOM

No Power on when the power button pressed.

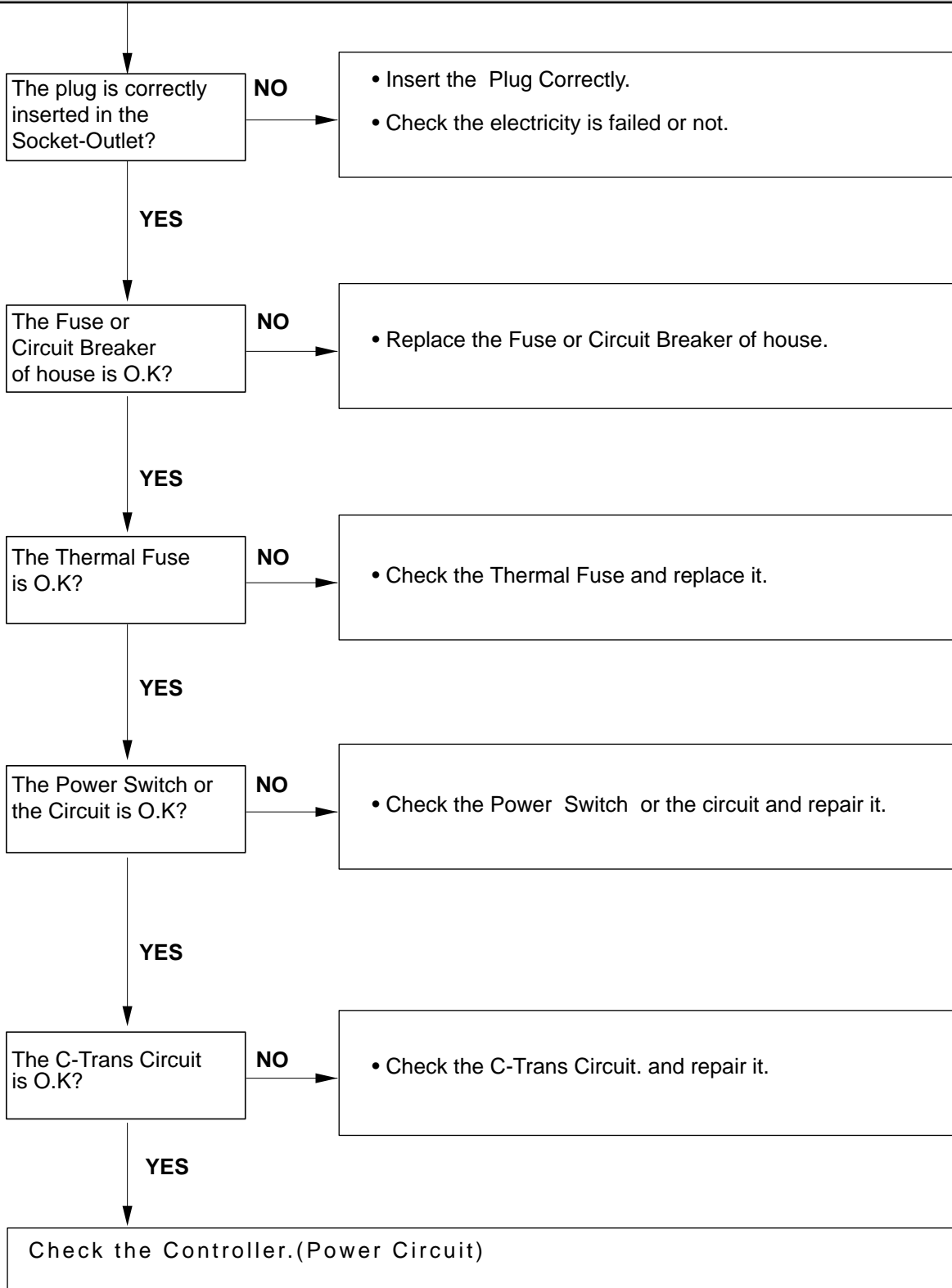

The Wash Pump/Motor does not run.

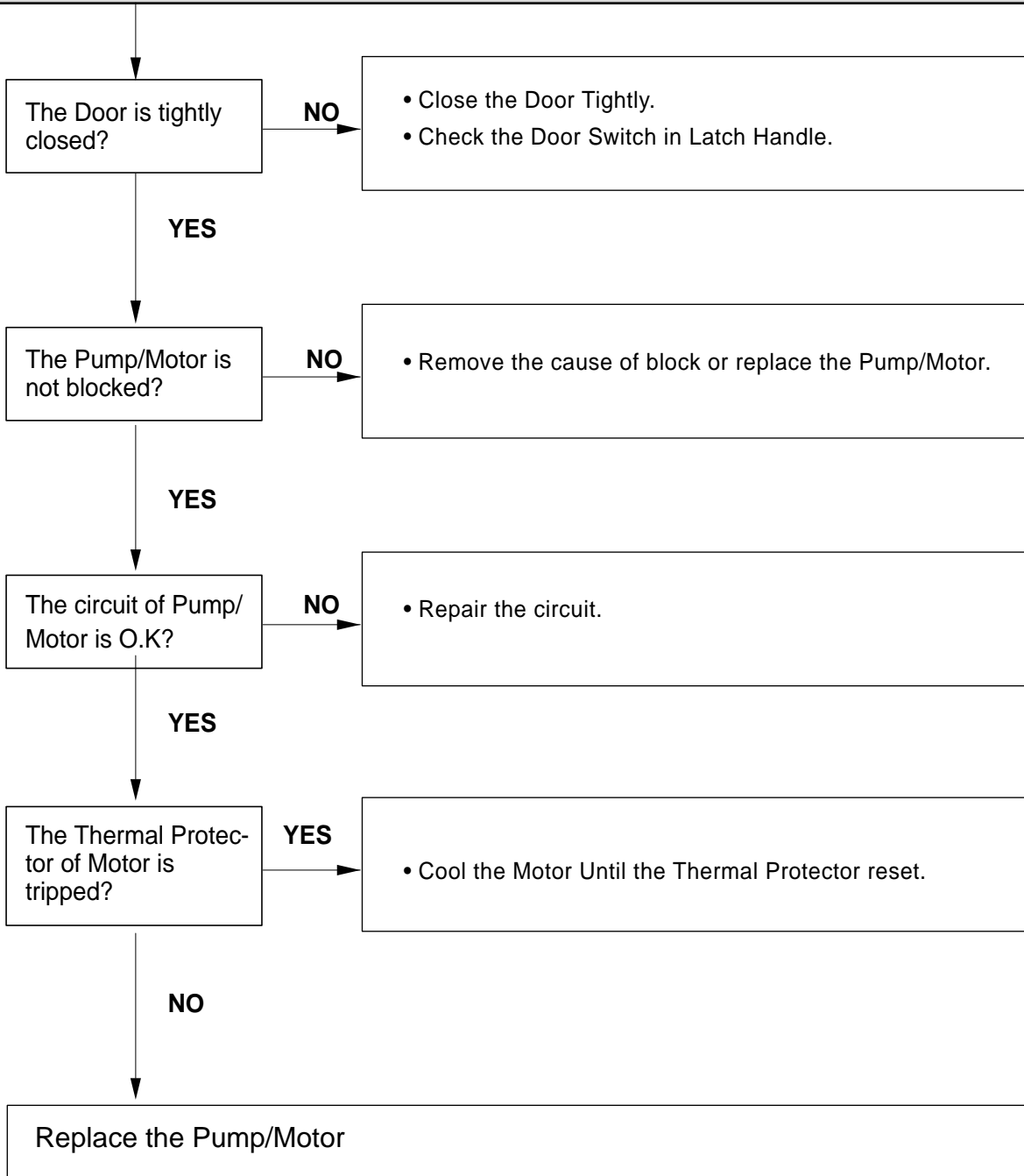

Washing Results are not Satisfactory

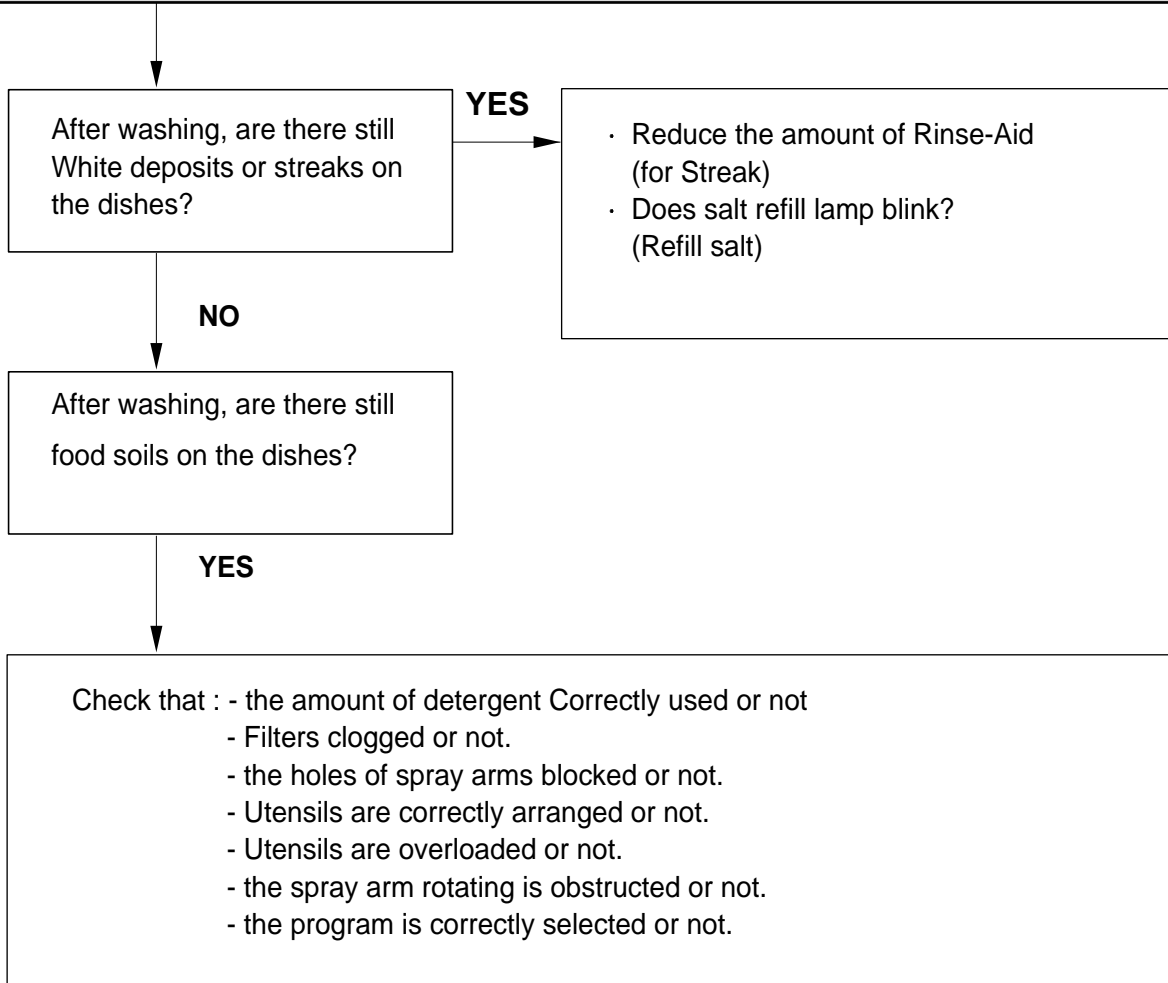

Dry Results are not satisfactory

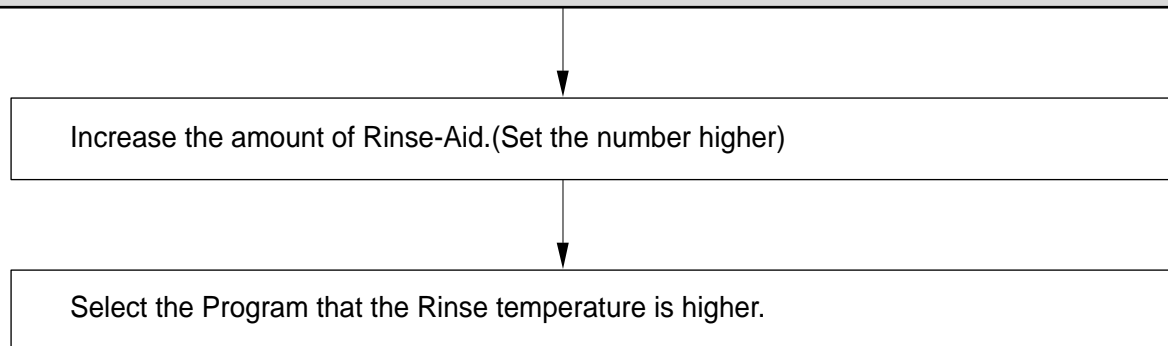

Power Button not automatically off after operation.

Check the button is blocked by foreign materials.

Check the Power Switch.(Replace it, if necessary.)

Check the Controller.(Replace it, if necessary.)

9. INSTALLATION INSTRUCTION

Step1: Prepare Cupboard opening

1. This dishwasher is designed to fit to the size shown as below.
2. Select a location as close to sink as possible for easy connections to water and drain lines.
3. The dishwasher should not be installed more than 3 meters from sink for proper drainage.
4. If dishwasher is to be installed in corner, minimum 5 cm of space is required between the washer and an adjacent cabinet or a wall.

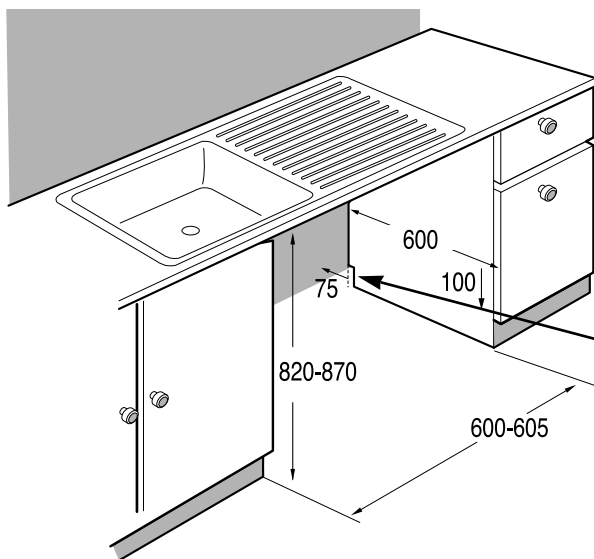

If bare chipboard is adjacent to or above the dishwasher, it should be sealed with a waterproofing paint or sealant to prevent swelling due to steam.

Cut out for hoses and electrical cables on either side.
(approx.. 100 X 75)

Cupboard Opening Dimension
(mm)

- Ensure the floor under the dishwasher is at the same level as the rest of the room to allow for any service requirements.

Step 2 : PREPARE ELECTRICAL WIRING

CAUTION

For personal safety, remove house fuse or open circuit breaker before installation.

Do not use an extension cord or adapter plug with this appliance.

Electrical and grounding connections must comply with the national electrical code/provincial and municipal code and/or other local codes.

1. This appliance must be supplied with correct rating voltage and hertz as shown on instruction manual, and connected to an individual, properly grounded branch circuit, protected by minimum 15 amp circuit breaker or time delay fuse.
Wiring must be 2 wires with ground.
2. The power point must be in a accessible location adjacent to and not behind the dishwasher and within 1.2 meters of the dishwasher side. A correctly rated, wired and earthed extension cord may be used if necessary.
(See Fig. A)
3. The power point must be correctly earthed, if in doubt, have it checked by a qualified Electrician. No other appliance shall be connected to the same plug outlet by a double adapter or similar plug.

Step 3 : PREPARE DISHWASHER FOR INSTALLATION

1. Lay the dishwasher on its back.
2. Adjust the legs to the needed height of cabinet as shown at below.

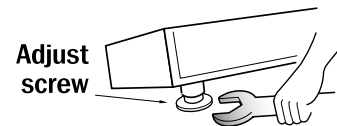

Step 4 : INSTALL THE DISHWASHER IN CUPBOARD

1. Before sliding the dishwasher into the cupboard opening, all necessary final height adjustment and balancing adjustment should be done using the spanner.
2. Slide the dishwasher into the cabinet opening carefully. Make sure that the drain hose inside the cabinet should not be kinked or exceeded.

CAUTION

If the height of cupboard is below 850mm, you should remove the top table by unscrewing the 2 screws. (Two of front and two of rear)

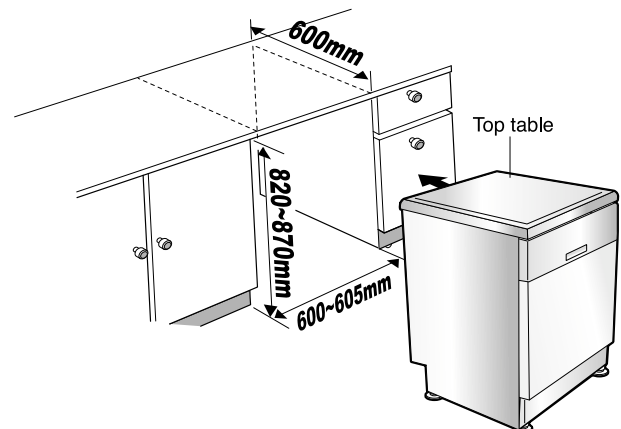

Step 5 : DRAIN LINE CONNECTION

1. If the end drain hose does not fit to the drain line, use a piece of rubber connector (not supplied) that must be resistant to heat and detergent and may be obtained from a plumbing shop.
2. There are 2 typical connections as shown in Figure A, B

¥The recommended methods of drain hose connection must be adhered to within the areas of Water Board Authority. Several other options are commonly used outside this area and local council or plumbers should be able to advise of these.

¥The S trap spigot must be drilled out cleanly and free of obstruction to its maximum internal diameter, if used for drainage.

¥To prevent syphoning, one of the following instruction methods must be followed :

- When the drainage hose is connected to a sink S trap or waste disposal unit, the hose must be looped up to the under side of the bench top and secured.

Fig. A

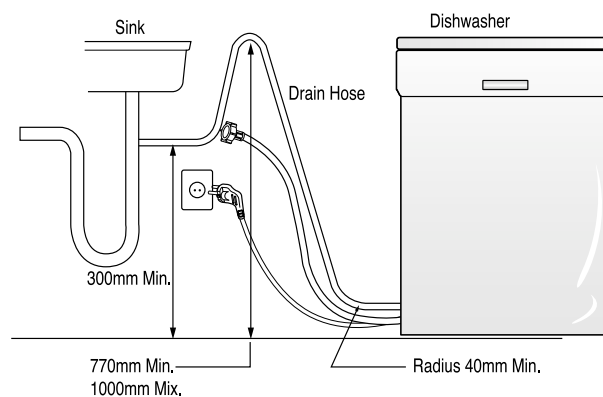

- When the drain hose is connected to a separate stand pipe, it is essential that an air tight connection is made. Refer to Fig. B

Fig. B . Drainage connection-stand pipe

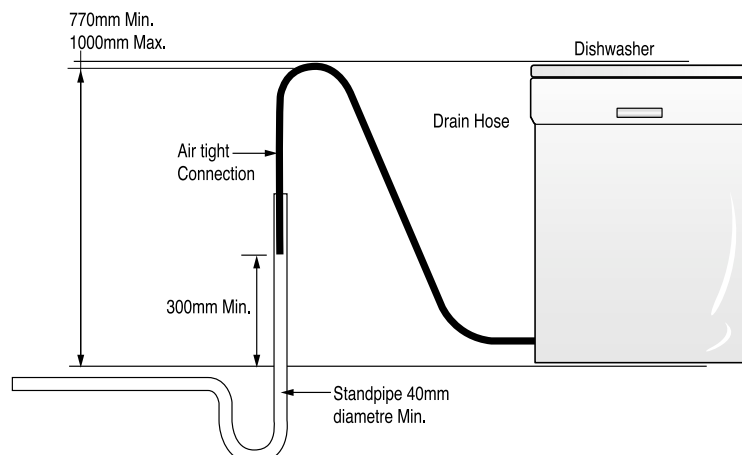

Drain Hose Extension

- Drain Hose extension kits are available from through your local service centre.

Extend drain Hose as shown below.

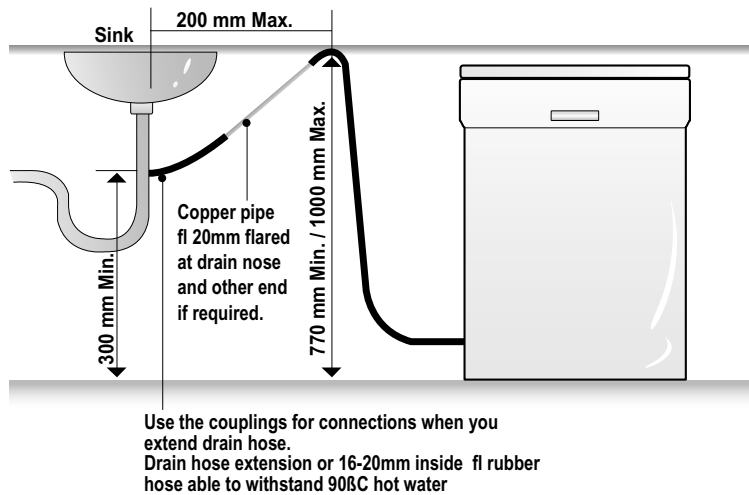

Step 6 : WATER SUPPLY CONNECTION

1. Connect the water supply hose to the valve behind dishwasher and the water tap as shown in figure.
This dishwasher may be fed with either hot or cold water. If the water can not be maintained below 65°C, the dishwasher must be connected to cold water.
2. When connecting, the sealing tape or sealing compound should be used to avoid water leaks.

Make sure that the line is not kinked or sharply bent.

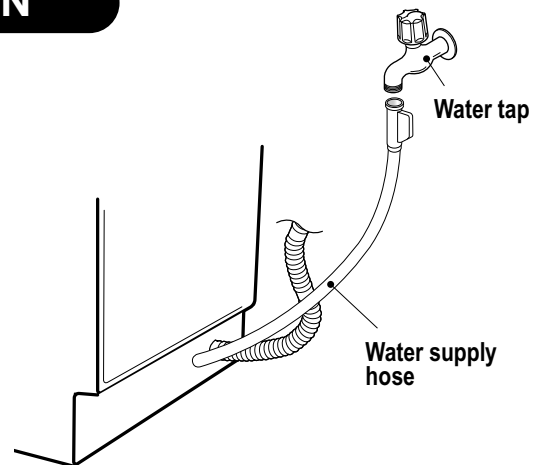

Step 7 : FINAL CHECK AND ASSEMBLING

1. Securely hand tighten supply hose to water supply.
Plug power cord into an earthed power point and switch on.
2. Operate the dishwasher through one cycle (Quick cycle is recommended) to check for water leak and operating conditions.

10. EXPLODED VIEW

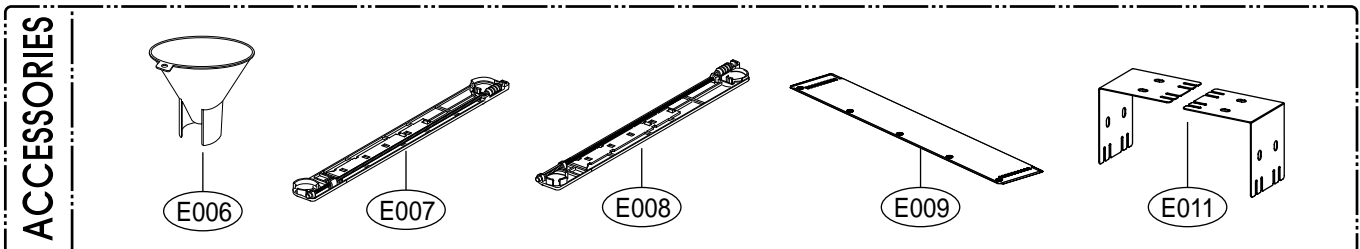
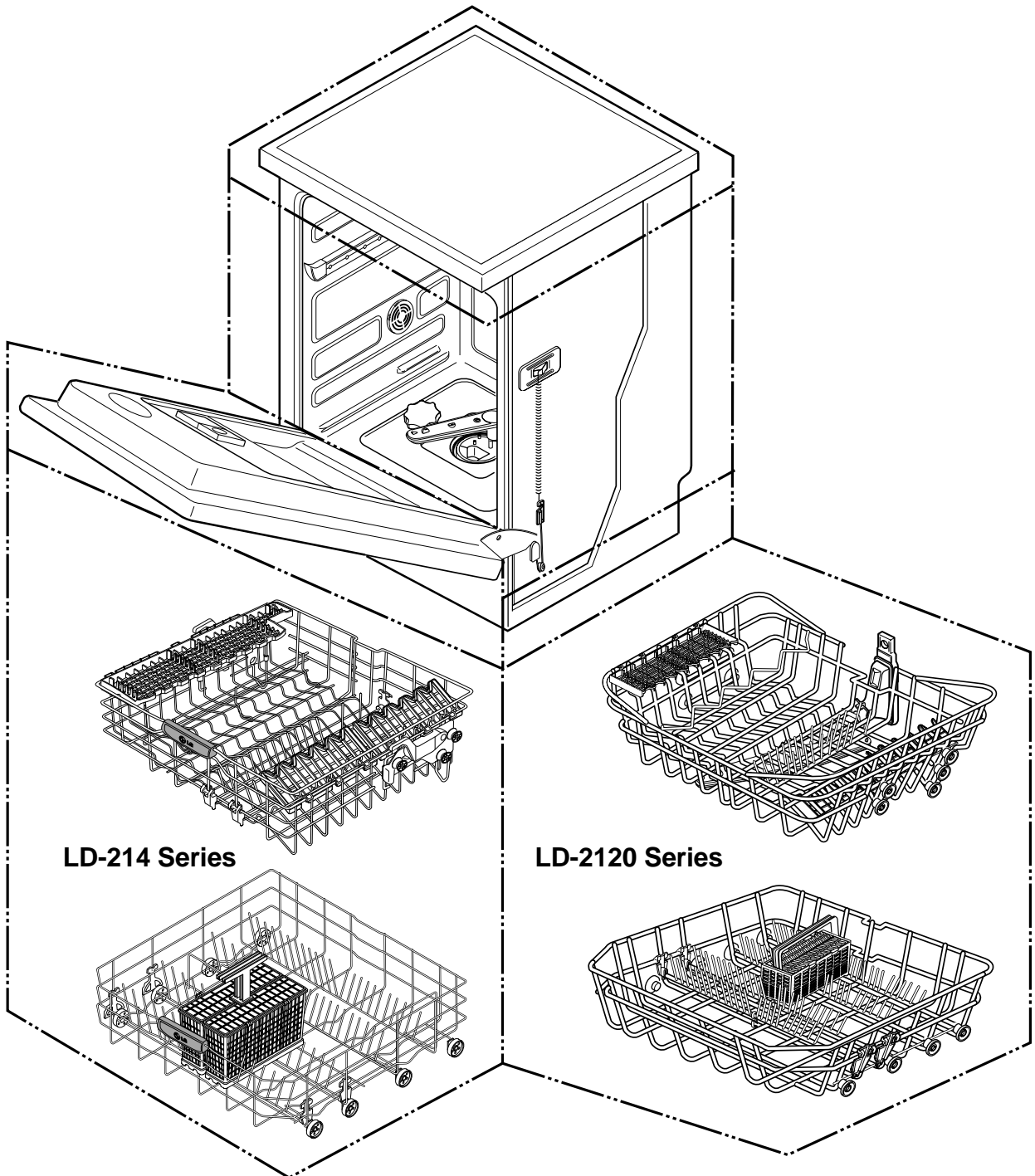

EXPLODED VIEW

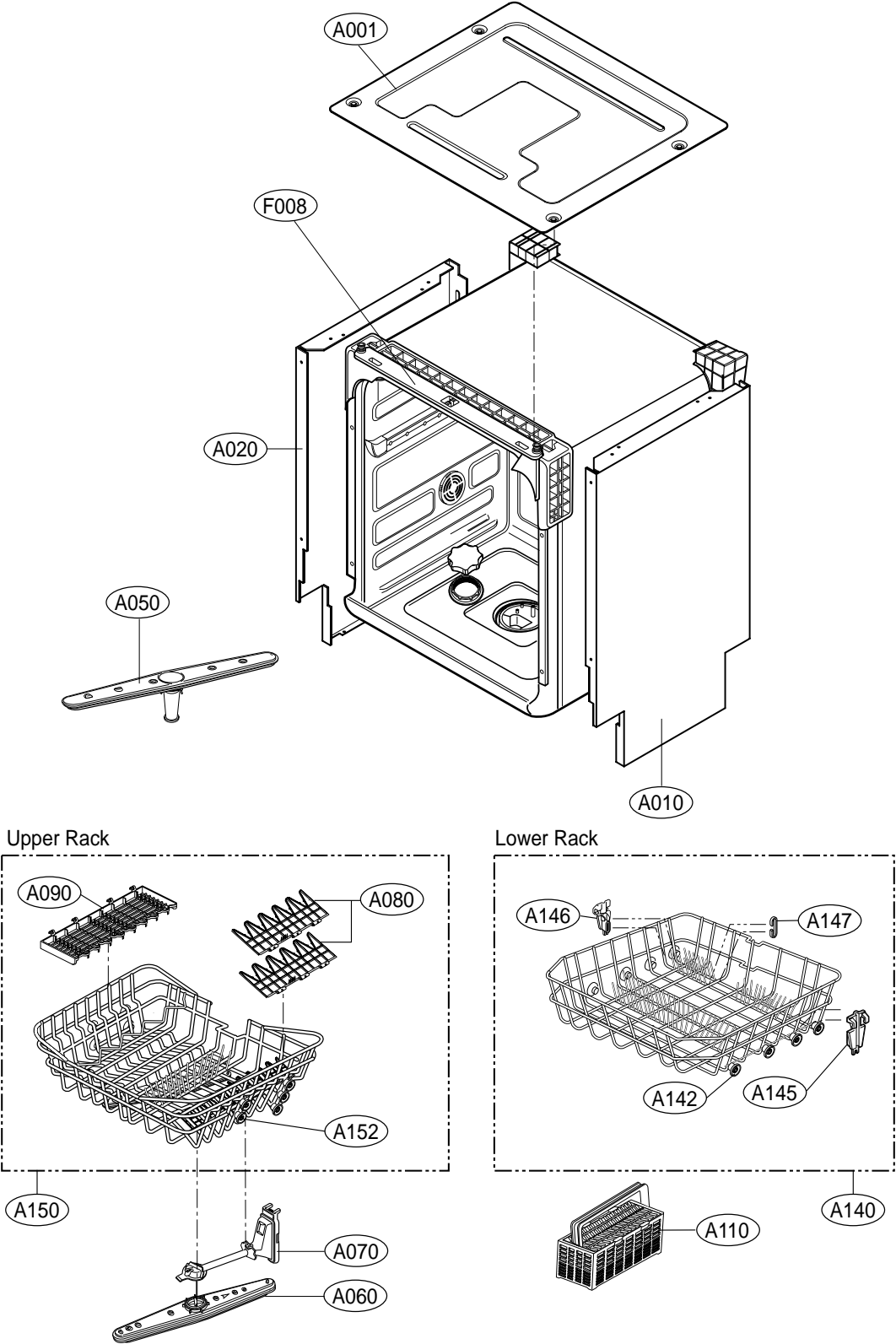

EXPLODED VIEW

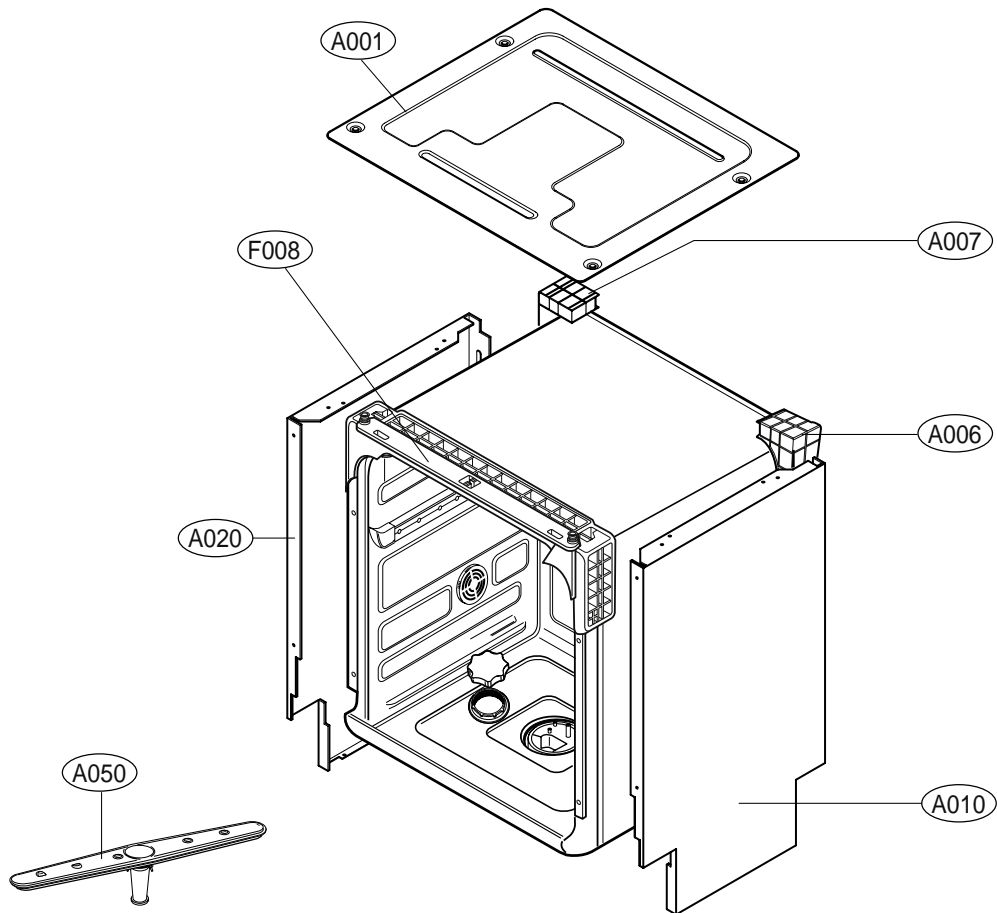

Upper Rack

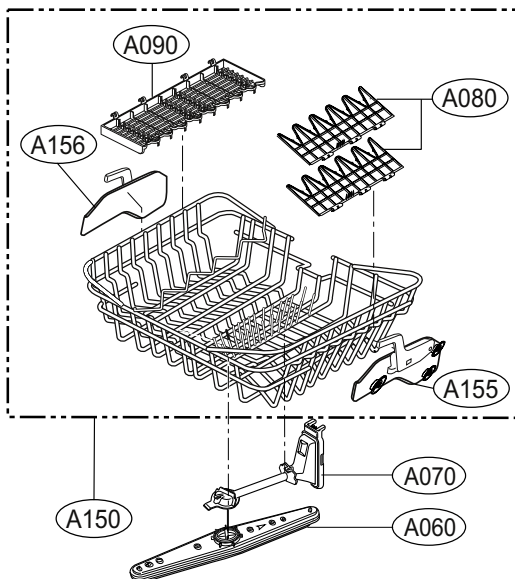

Lower Rack

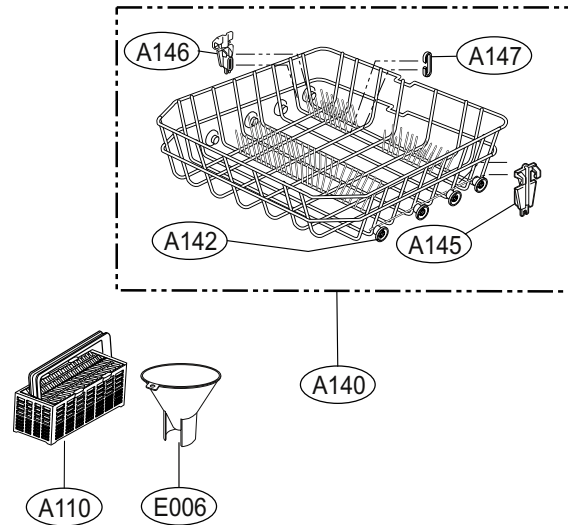

EXPLODED VIEW

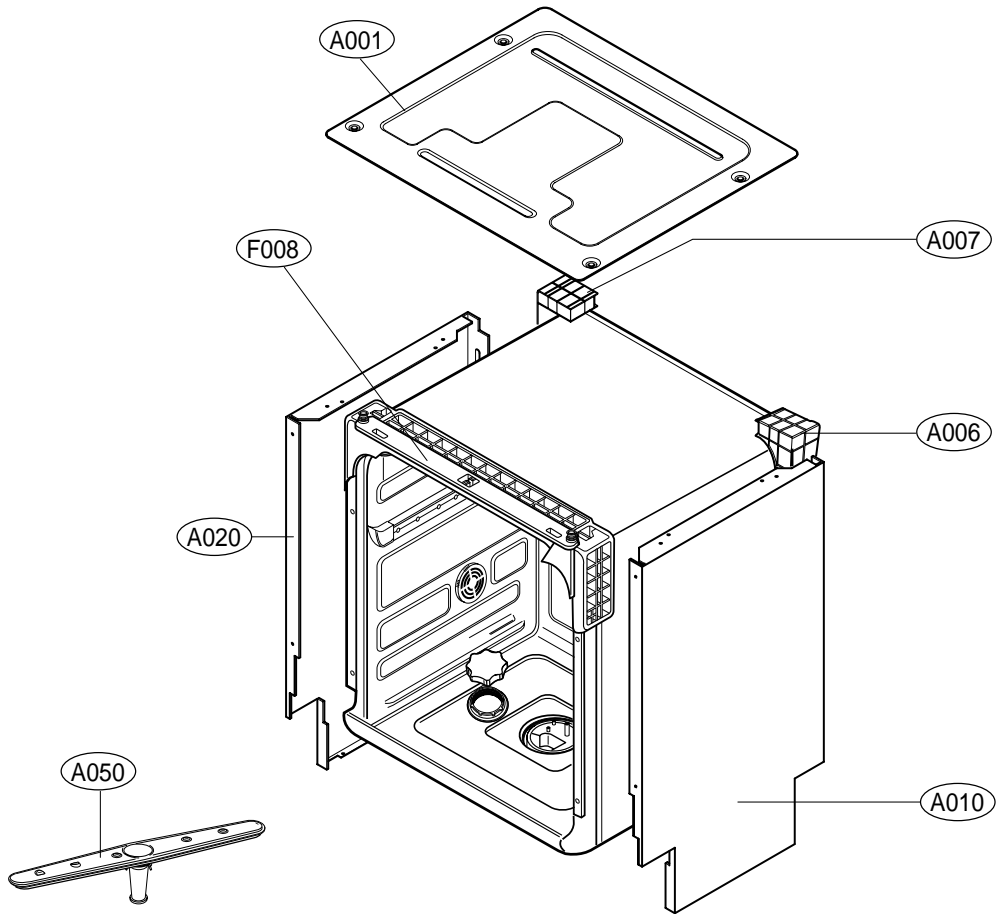

Upper Rack

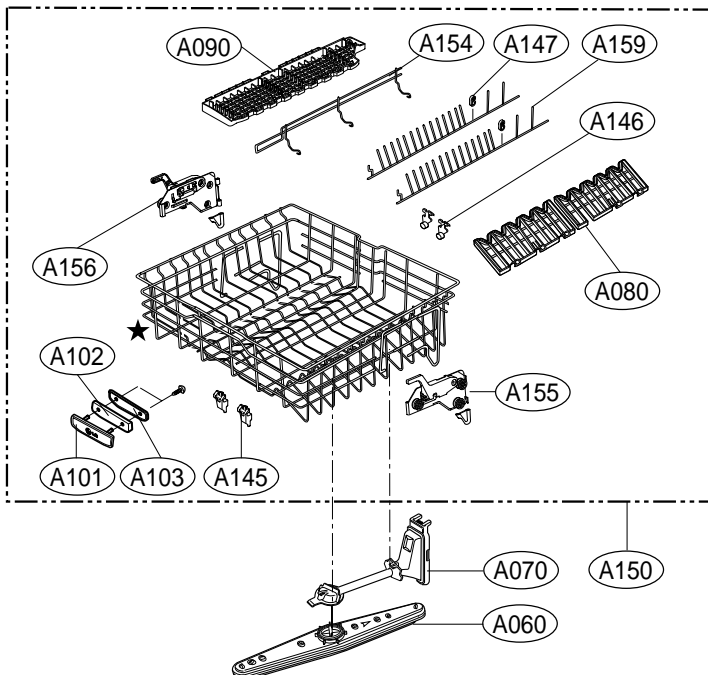

Lower Rack

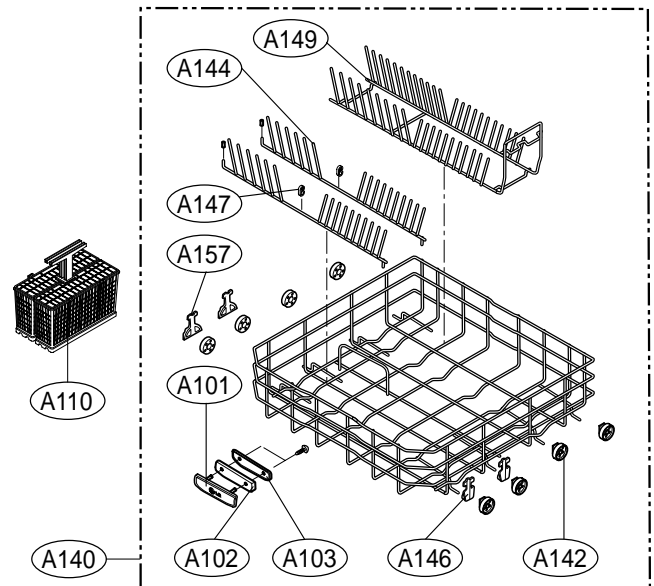

EXPLODED VIEW - TUB ASSEMBLY

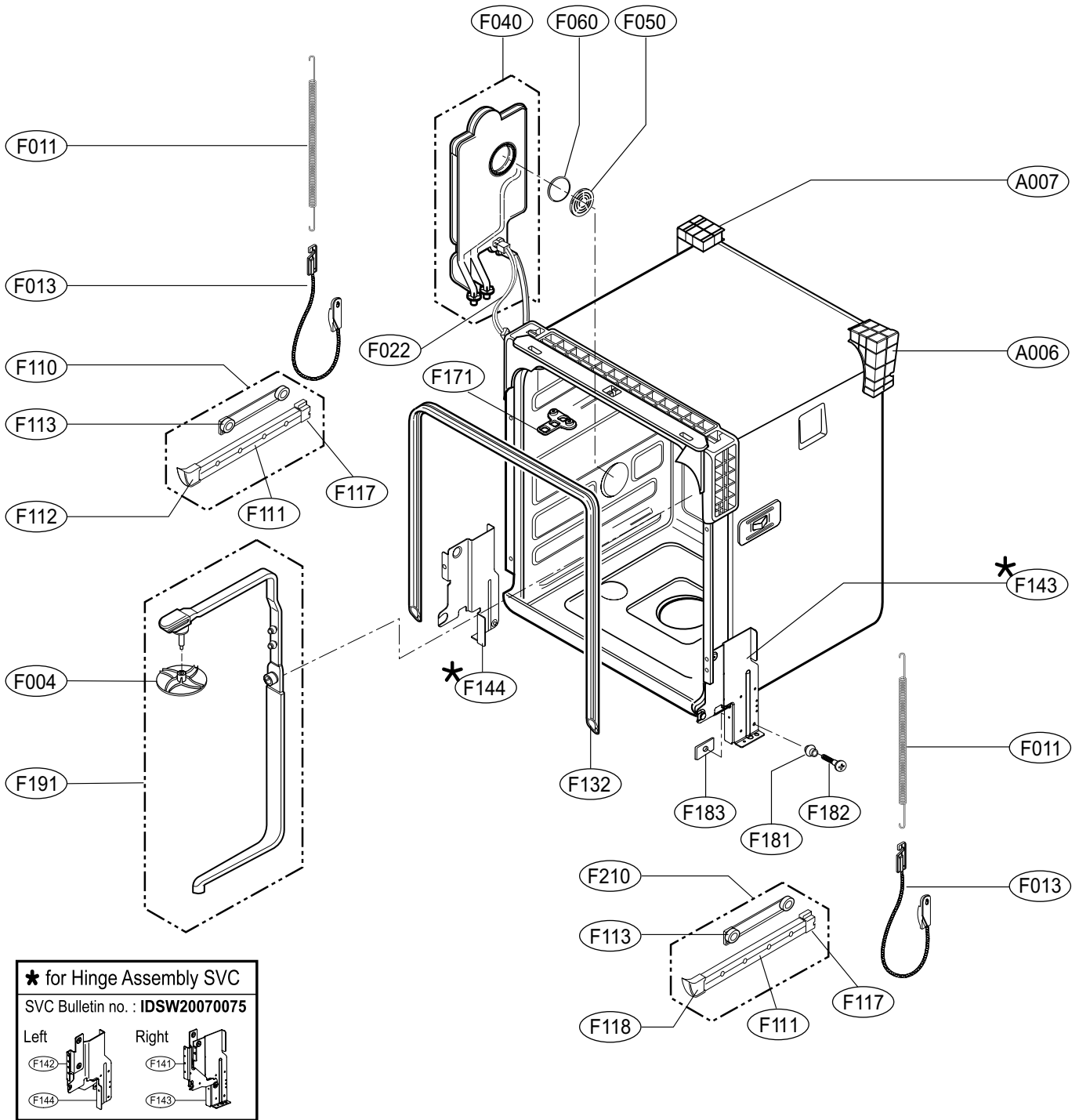

EXPLODED VIEW - PANEL / DOOR ASSEMBLY

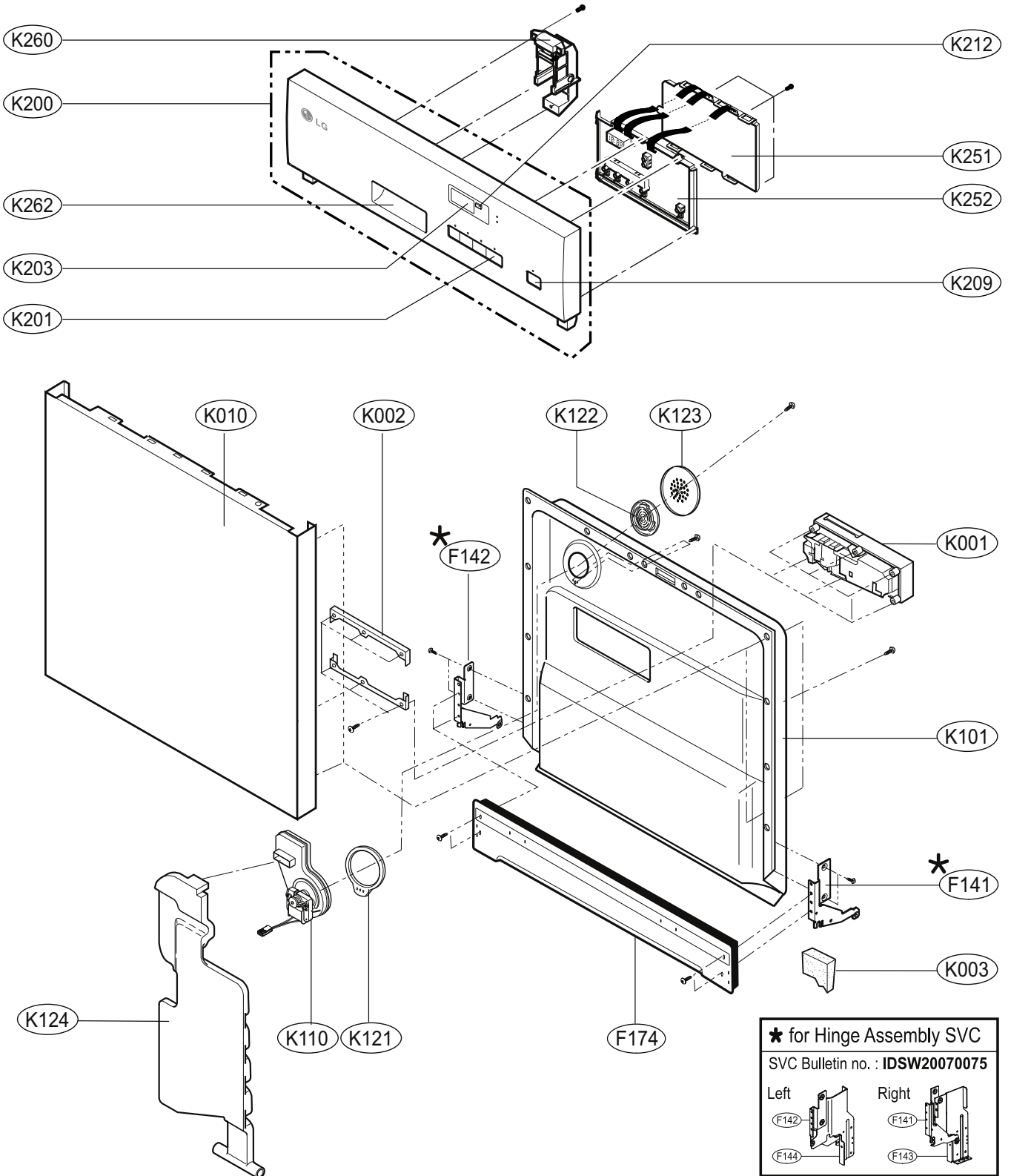

EXPLODED VIEW - PANEL / DOOR ASSEMBLY

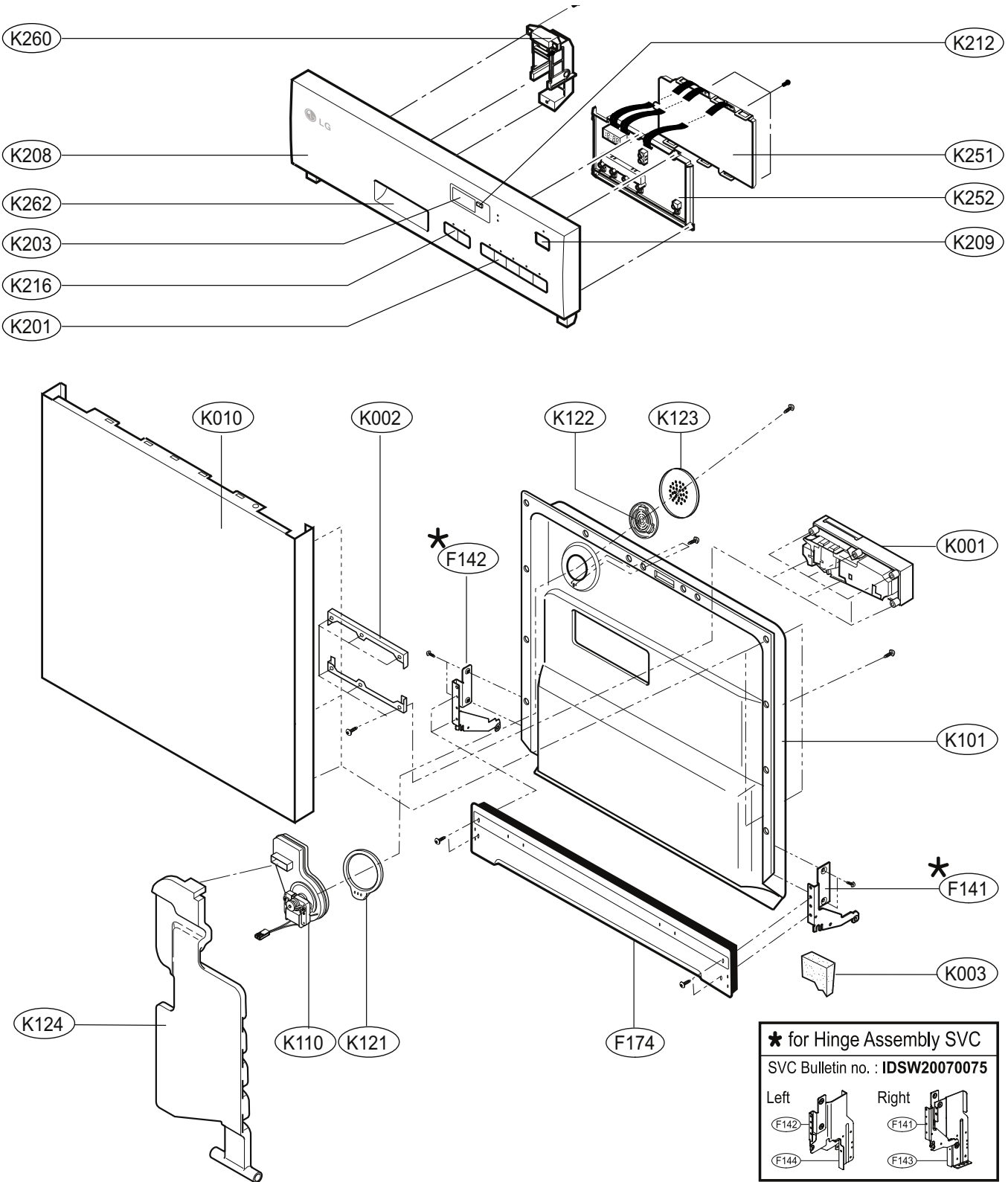

EXPLODED VIEW - BASE ASSEMBLY

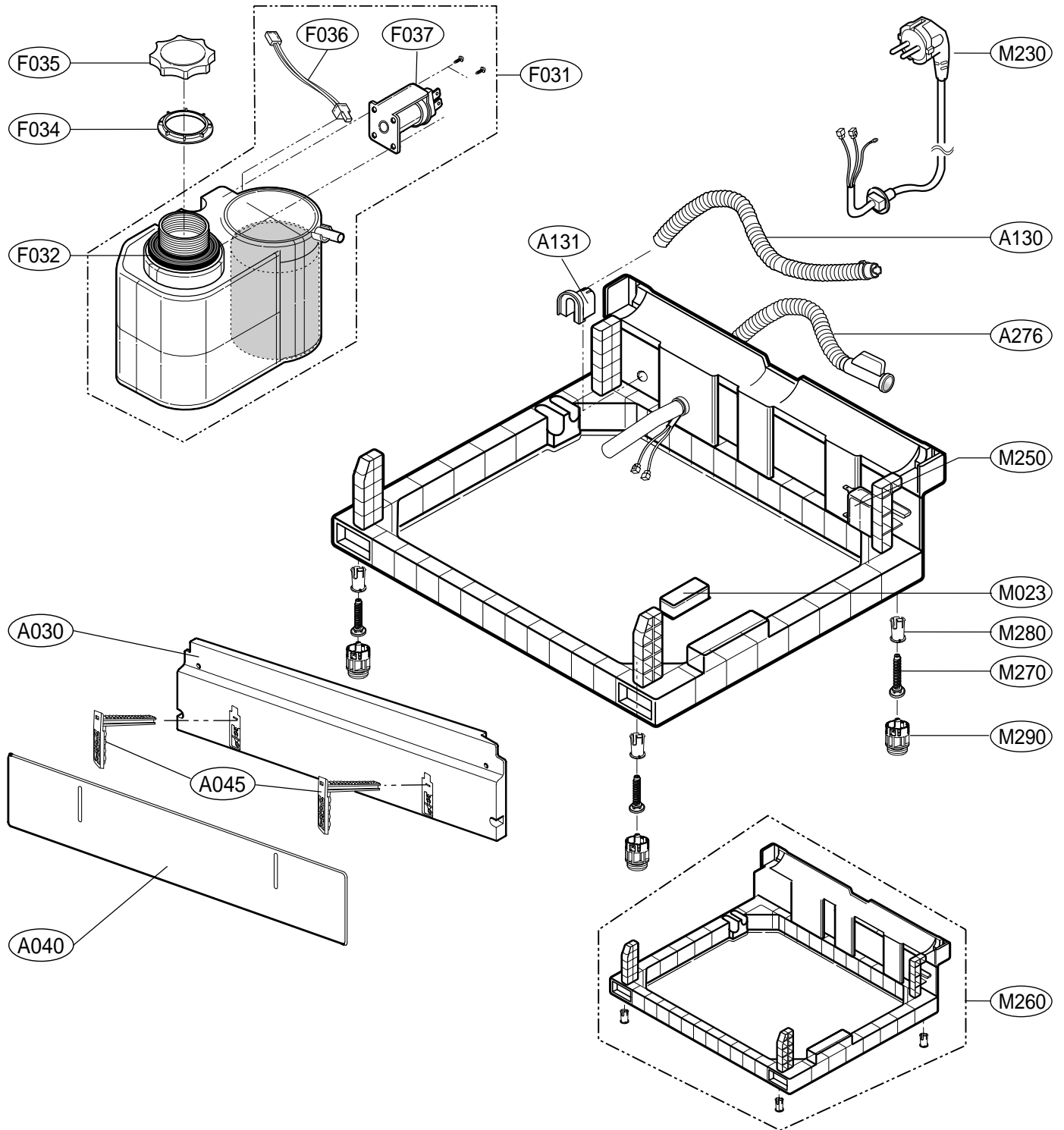

EXPLODED VIEW - BASE ASSEMBLY

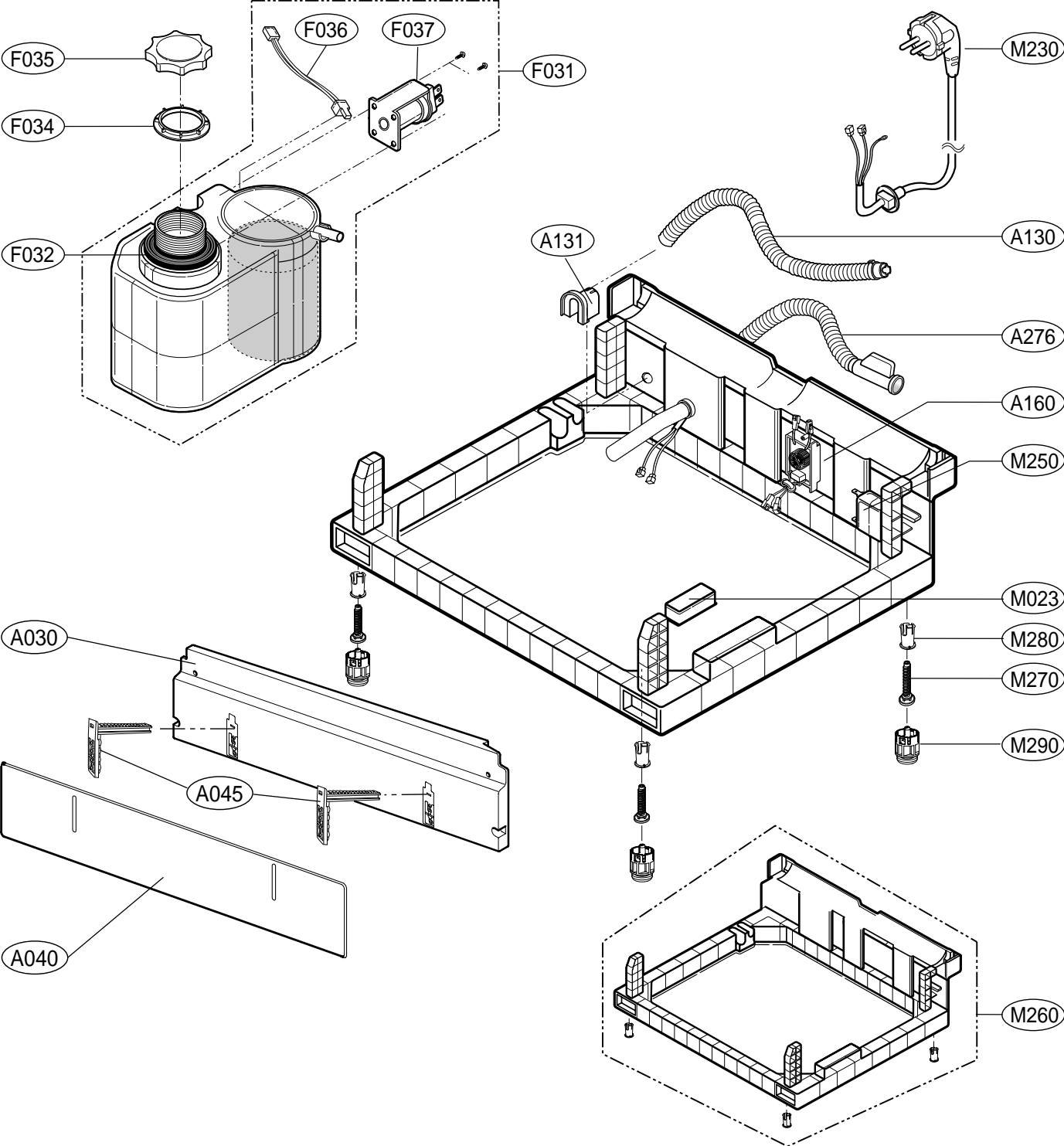

EXPLODED VIEW - SUMP ASSEMBLY

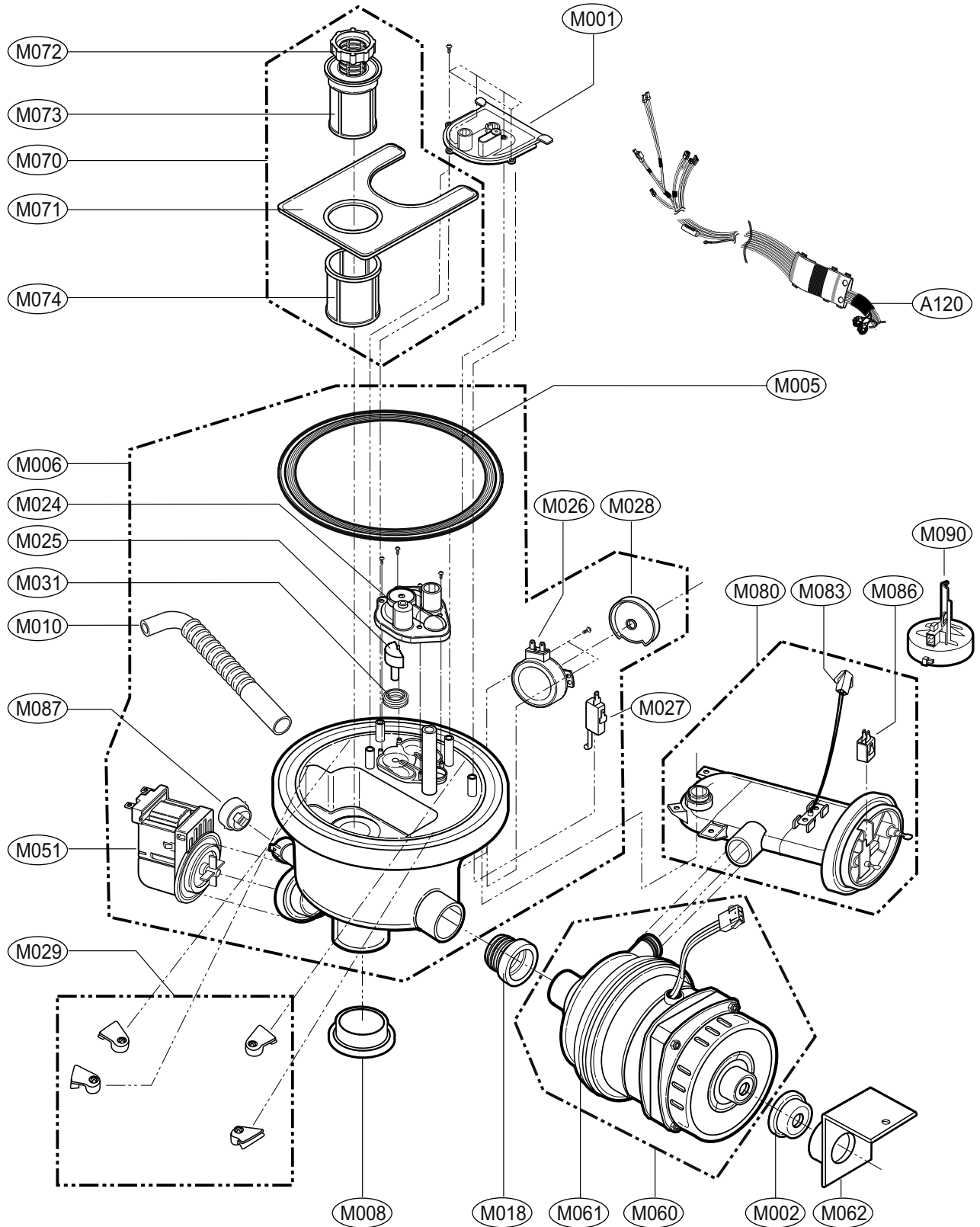



MEMO



LG Electronics Inc.

P/No. : 3828DD3007G