

10. EXPLODED VIEW AND PART LIST

10-1. THE PART LIST OF CABINET ASSY

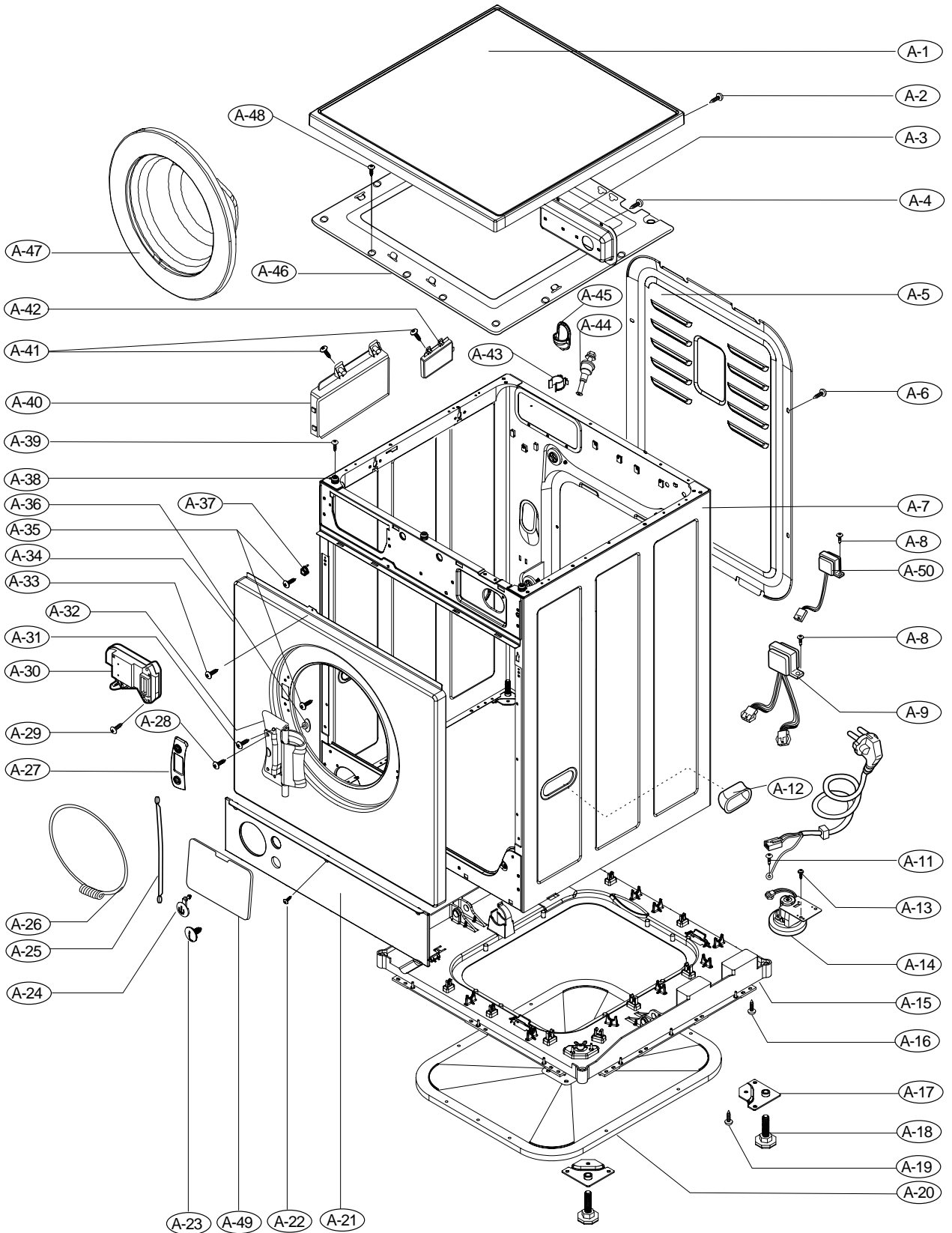

THE PART LIST OF CABINET ASSY

L/No.	PART NAME		PART NO.	SVC CORD	Q' TY	SPEC
A-1	PLATE ASSY(TOP)		3301FR1229B	R	1	
A-2	SCREW, TAP TITE(S) [BINDING HEAD]		1SBF0402418			
A-3	HOLDER, VALVE		4930FR3154A		1	WD-102(4)1WH
			4930FR3154B		1	
A-4	SCREW. TAPPING [TURSS HEAD]		1TTL0402432		2	
A-5	BACK COVER		3808FR1202A		1	
A-6	SCREW, TAP TITE(S) [BINDING HEAD]		1SBF0402418		4	
A-7	CABINET ASSY		3901FR0045A		1	
A-8	SCREW, TAP TIE(S) [BINDING HEAD]		1SBF0402418			
A-9	TRANSFORMER, CONTROLLER		6170FR2027E	R	1	220-240VAC
A-10	POWER CORD ASSY *See Appendix(type of power cord)		6411FR1169B	R	1	C-4-2
			6411FR1169D		1	S-2-1
			6411FR1169E		1	B-5
			6411FR1169F		1	B-3
			6411FR1169K		1	B-3(BSI)
			6411FR1169L		1	B-3(SISIR)
			6411FR1169N		1	C-4-2
			6411FR1169P		1	S-2-3
		6411FR1169Q		1	S-2-1	
A-11	SCREW		4000W4A003A		1	
A-12	HANDLE		3650FA3488J			
A-13	SCREW, TAP TITE(S) [BINDING HEAD]		1SBF0402418		1	
A-14	SENSOR PRESSURE	WD-1020W/1040W	6600FR1203A	R	1	
		WD-1021W(H)/1041W(H)	6600FR1203D	R	1	
A-15	BASE		3040FR0049A		1	
A-16	SCREW, TAP TITE(B) [FLAT HEAD]		1SBF0402618		13	
A-17	BRACKET, BASE		4810FR4136A		4	
A-18	FEET ASSY		5413FR4154A	R	4	
A-19	SCREW. TAP[TITE(B) [FLAT HEAD]		1SBF0402618		8	
A-20	COVER, SILENT		3550FR1151A		1	
A-21	COVER, LOWER	WD-1020W/1040W	3550FR1212A	R	1	
		WD-1021W(H)/1041W(H)	3550FR1166A	R	1	
A-22	SCREW, TAP TITE(B) [FLAT HEAD]		1SBF0402618		4	

L/No.	PART NAME		PART NO.	SVC CORD	Q' TY	SPEC
A-23	CAP(REMAINING HOSE)		5006FR3146A		1	
A-24	OPENER, DOOR		5870FR3147A		1	
A-25	STRAP		4640FR4118A		1	
A-26	CLAMP ASSY, CABINET GASKET		2W20017A		1	
A-27	GUIDE		4974FR4145A		1	
A-28	SCREW		4000FD4191A		2	
A-29	SCREW, TAPPING [TRUSS HEAD]		1TTL0403032		2	
A-30	SWITCH ASSY, DOOR LOCK	WD-1020W/1040W	6601FR1119C	R	1	220-240VAC
		WD-1021W(H)/1041W(H) (AUSTRALIA)				
		WD-1021W/1041W				
A-31	SCREW		4000FD4191B		2	
A-32	HINGE ASSY		4775FR2114A		1	
A-33	SCREW, TAPPING [TRUSS HEAD]		1TTL0403332		1	
A-34	COVER, CABINET		3550FR1213A		1	
A-35	SCREW, TAP TITE(C) [PAN HEAD]		11SCPF040268		4	
A-36	HOLDER		4930FR4158A		2	
A-37	HOLDER		4930FR4157A		2	
A-38	HOLDER		4930FR4165A		3	
A-39	SCREW, TAP TITE(S) [PAN HEAD SPR W]		1SCBF040319		3	
A-40	PWB ASSY(MAIN)	WD-1020W/1040W	6871FC1156A	R	1	220-240VAC
		WD-1021W(H)/1041W(H)	6871FC1156		1	220-240VAC
A-41	SCREW, TAPPING [TRUSS HEAD]		1TTL0403018		4	
A-42	PWB ASSY (POWER)		6871FC2262	R	1	220-240VAC
A-43	HOLDER		4930FR3151A		1	
A-44	BOLT ASSY, TRANSIT		4011FR3159A		4	
A-45	BUSHING		4830FR3107A		1	
A-46	COVER, INNER		3550FR2071A		1	
A-47	DOOR ASSY		3581FR1200A	R	1	
A-48	SCREW		1SBF0402418		9	
A-49	LOWER COVER CAP	WD-1021W/1041W	5006FR3179A	R	1	
A-50	REACTOR	WD-1021W/1041W	5874FA2381A	R	1	SEMKO

10-2 THE EXPLODED VIEW OF CONTROL PANEL & DISPENSER ASSY

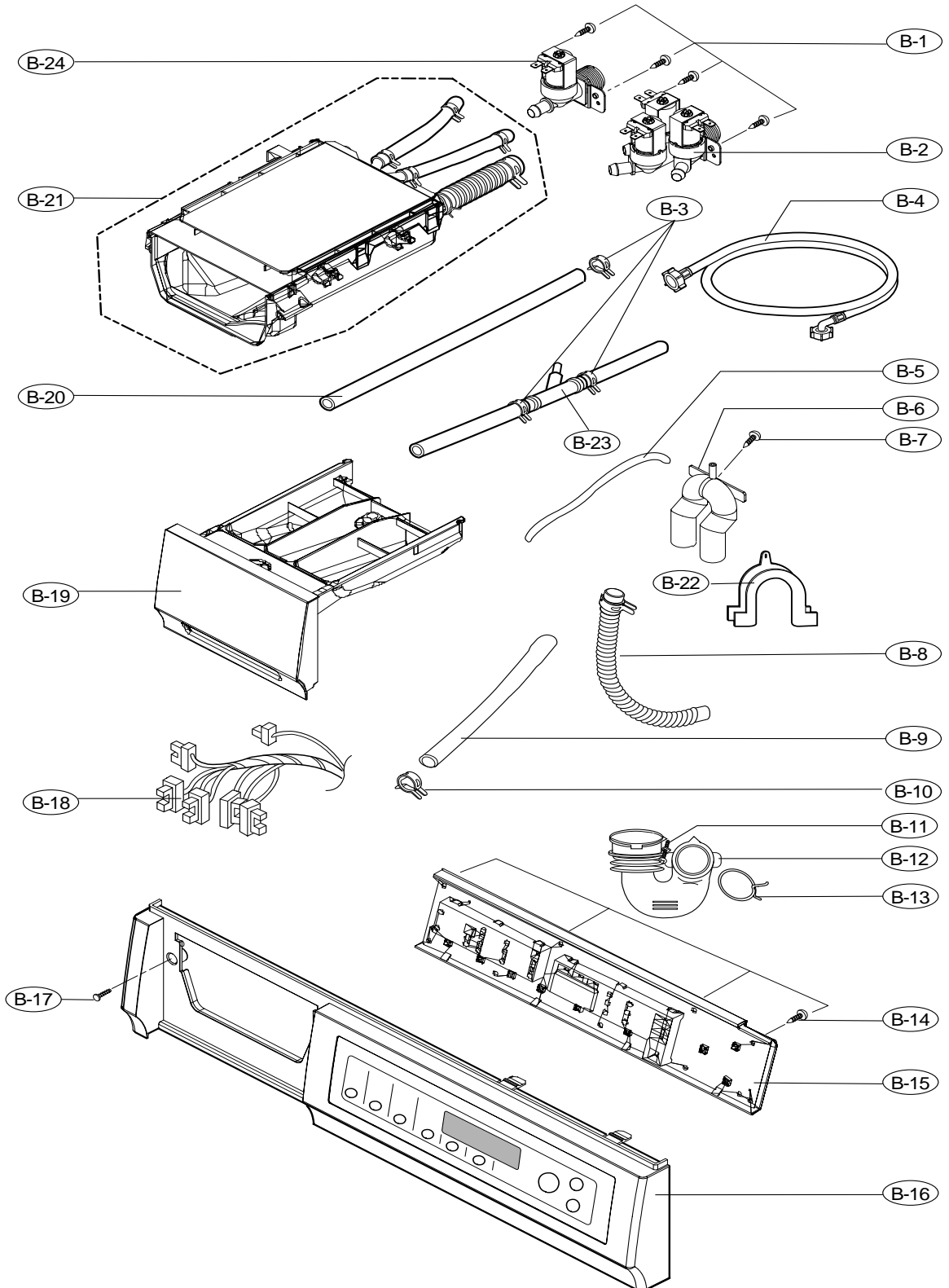

THE PARTS LIST OF CONTROL PANEL & DISPENSER ASSY

L/No.	PART NAME		PART NO.	SVC CORD	Q' TY	SPEC
B-1	SCREW, MACHINE [PAN HEAD]		1MPC0402432		2	
B-2	VALVE	WD-1020W/1040W	5220FR2009D	R	1	220-240VAC
		WD-1021W(H)/1041W(H)	5220FR2075A	R	1	220-240VAC
B-3	RING, SNAP		4861FR3068P			
B-4	HOSE ASSY, INLET		5214FA1146	R	1	
			5215FD3715	R	1	
			3W40102	R	1	
B-5	HOSE		5214FR4125B		1	
B-6	CONNECTOR (MECH), DRAIN HOSE		4932FR3156A		1	
B-7	SCREW, TAP TITE(B) [FLAT HEAD]		1SBF0402618		1	
B-8	HOSE ASSY, DRAIN		5214FR3018B	R	1	
B-9	HOSE, PUMP		5214FR2090A	R	1	
B-10	RING, SNAP		4350FA3272E		2	
B-11	CLAMP		4860FR3092D		1	
B-12	BELLOWS		4738FR2065A	R	1	
B-13	RING, SNAP		3W500120		1	
B-14	SCREW		4W51132A		9	
B-15	PWB ASSY(DISPLAY)		6871FC2272A	R	1	
B-16	PANEL ASSY, CONTROL	WD-1020W/1021W(H)	3721FR1227	R	1	
		WD-1040W/1041W(H)	3721FR1196	R	1	
B-17	SCREW, TAPPING [TRUSS HEAD]		1TTL0403332			
B-18	LEAD WIRE ASSY		6877FR1195		1	
B-19	PANEL ASSY, DRAWER	WD-1020W/1021W(H)	3721FR1228	R	1	
		WD-1040W/1041W(H)	3721FR1244	R	1	
B-20	HOSE		WD-1020W/1040W			
B-21	DISPENSER ASSY	WD-1020W/1040W	4925FR1137B	R	1	
		WD-1021W/1041W	4925FR1137D		1	
		WD-1021WH/WD-1041WH	4925FR1137E		1	
B-22	DRAIN HOSE HANGER		3W50712A		1	
B-23	HOSE ASM(SHOWER)	WD-1021W(H)/1041W(H)	5215FR3197A		1	
B-24	VALVE	WD-1021WH/1041WH	5220FR1280A	R	1	220-240VAC

10-3 THE EXPLODED VIEW OF DRUM & TUB ASSY

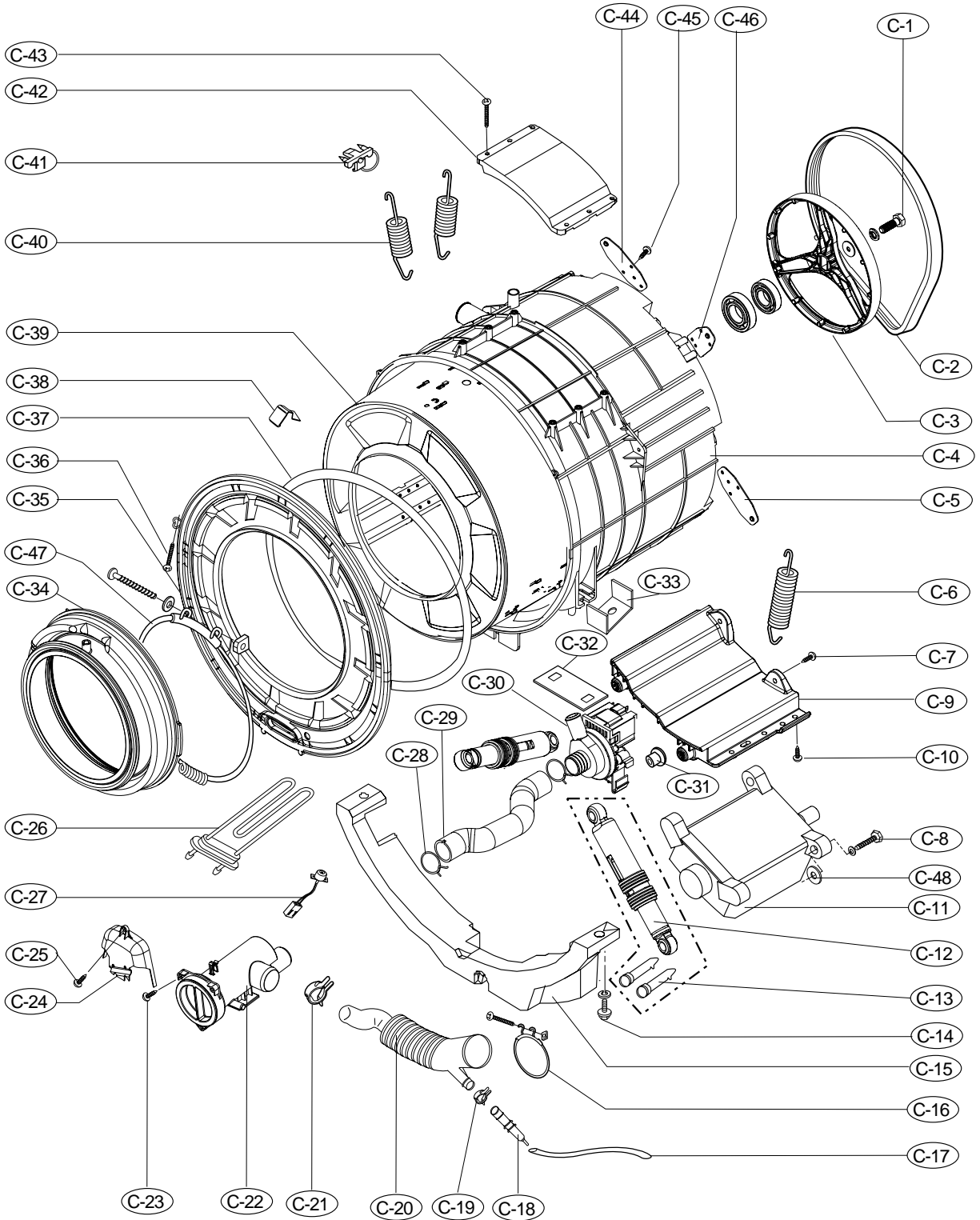





■ THE PART LIST OF DRUM & TUB ASSY

L/No.	PART NAME		PART NO.	SVC CORD	Q' TY	SPEC
C-1	BOLT ASSY		4011FR3173A		1	
C-2	BELT, POLY-V		4400FR3116A	R	1	
C-3	PULLEY		4560FR1149A	R	1	
C-4	TUB ASSY		3045FR0031A		1	
C-5	BRACKET		4810FR4167B		1	
C-6	SPRING		4970FR2084B	R	1	
C-7	SCREW		1TTL0503518		2	
C-8	SCREW		4040FR4051F		2	
C-9	BRACKET, MOTOR		4810FR1222	R	1	
C-10	SCREW		4000FA3115B		4	
C-11	MOTOR ASSY		4681FR1194A	R	1	220-240VDC
C-12	DAMPER ASSY		4901FR2080A	R	2	
C-13	HINGE		4774FR3118A	R	4	
C-14	BOLT ASSY		4011FR3173B		3	
C-15	WEIGHT, BALANCE		4844FR1179A		1	
C-16	CLAMP		4860FR3092C		1	
C-17	HOSE(SENSOR)		5214FR4125A	R	1	
C-18	CHAMBER, AIR		3504FR3134A	R	1	
C-19	CLAMP, HOSE		4861FR3068C		1	
C-20	BELLOWS		4738FR1145A	R	1	
C-21	CLAMP, HOSE		4861FR3068E		1	
C-22	HOUSING ASSY (MECH), PUMP		3661FR2078A		1	
C-23	SCREW, TAPPING [TURSS HEAD]		1TTL0403018		3	
C-24	PROTECTOR (MECH)		3740FR3043A		1	
C-25	SCREW, TAPPING [TURSS HEAD]		1TTL0403318		2	
C-26	HEATER ASSY	WD-1020W/1040W	5301FR1158A	R	1	220VAC2500W
		WD-1021W(H) WD-1041W(H)	5301FR1158B		1	240VAC2000W
			5301FR1158C		1	220VAC2000W
			5301FR1158D		1	230VAC2000W

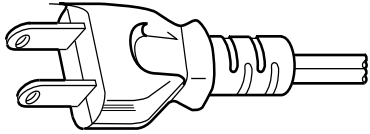
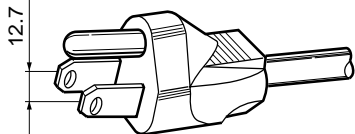
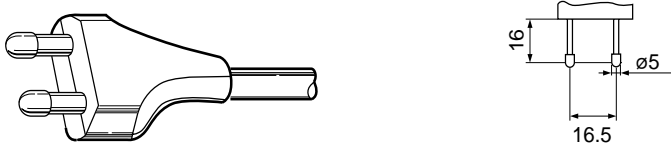
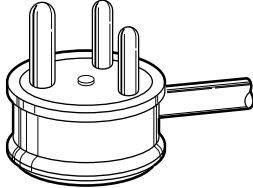
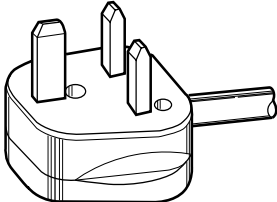
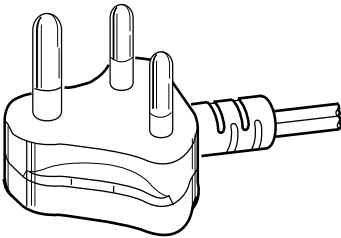
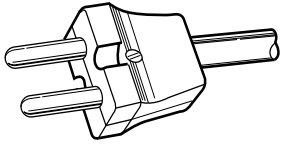
L/No.	PART NAME	PART NO.	SVC CORD	Q' TY	SPEC	
C-27	THERMISTOR	6322FR2046B	R	1		
C-28	CLAMP, HOSE	4861FR3068C		2		
C-29	INLET HOSE	5214FR3135A	R	1		
C-30	PUMP ASSY	5859FR2077A	R	1	220-240VAC 60Hz	
		5859FR2077B		1	220-240VAC 50Hz	
		WD-1021W(H)/1041W(H)		5859FR2077C	1	Australia
C-31	RUBBER	5040FR4168A		4		
C-32	PROTECT FILM, PUMP	WD-1020W/1040W		5135FR4151B	1	
		WD-1021W(H)/1041W(H)		5859FR4151A	1	
C-33	BRACKET	4810FR4116A		3		
C-34	GASKET ASSY	4987FR1165A	R	1		
C-35	COVER, TUB	3044FR0027A		1		
C-36	SCREW, TAPPING [TURSS HEAD]	1TTL0403318		3		
C-37	SEAL	4036FR4123A		1		
C-38	CLAMP, TUB	4860FR4124A		11		
C-39	TUB, DRUM ASSY	3044FR1220A		1		
C-40	SPRING	4970FR2084A	R	2		
C-41	HOLDER(SPRING)	4930FR3040A	R	3		
C-42	WEIGHT, BALANCE	4844FR1223A		1		
C-43	SCREW	4000FA3115B		6		
C-44	BRACKET	4810FR4166B		1		
C-45	SCREW	1TTL0503518		12		
C-46	BRACKET	4810FR4126B		2		
C-47	TUB GASKET CLAMP ASSY	4861FR2086A	R	1		
C-48	NUT	1NZZFR4175A		2		

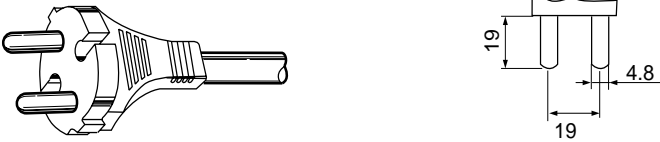
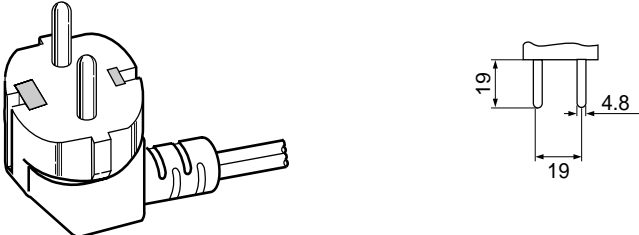
■ APPENDIX(The type of power cord)

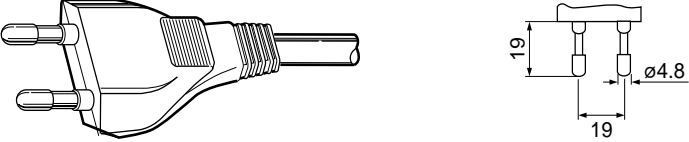
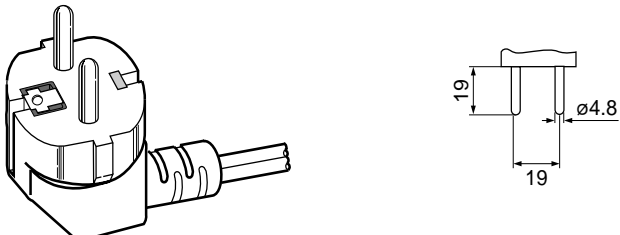
TYPE	TYPE OF PLUG	POWER CORD P/No.												
A-1		-												
A-2		-												
B-1		-												
B-2	 <table border="1" data-bbox="725 943 1020 1076"> <tr> <td>2A</td> <td>2PIN</td> <td>3.5Ø</td> <td>EPIN 5Ø</td> </tr> <tr> <td>5A</td> <td>2PIN</td> <td>5Ø</td> <td>EPIN 7Ø</td> </tr> <tr> <td>15A</td> <td>2PIN</td> <td>7Ø</td> <td>EPIN 8.6Ø</td> </tr> </table>	2A	2PIN	3.5Ø	EPIN 5Ø	5A	2PIN	5Ø	EPIN 7Ø	15A	2PIN	7Ø	EPIN 8.6Ø	-
2A	2PIN	3.5Ø	EPIN 5Ø											
5A	2PIN	5Ø	EPIN 7Ø											
15A	2PIN	7Ø	EPIN 8.6Ø											
B-3		6411FR1169F												
B-5		6411FR1169E												
C-1		-												

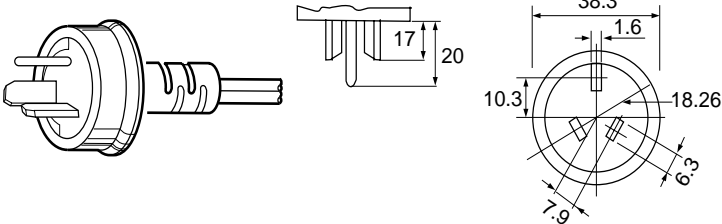
TYPE	TYPE OF PLUG	POWER CORD P/No.
C-2-1		-
C-2-2		6411FD1096V
C-3-1		-
C-3-2		-
C-4-2		6411FR1169B 6411FR1169N
C-5		-
S-2-1		6411FR1169D 6411FR1169P 6411FR1169Q