

website : <http://www.LGService.com>  
e-mail : <http://LGService.com/techsup.html>

# WASHING MACHINE SERVICE MANUAL

## CAUTION

READ THIS MANUAL CAREFULLY TO DIAGNOSE TROUBLE  
CORRECTLY BEFORE OFFERING SERVICE.

**MODEL : WD(M)-106(8)0F(H)D/WD(M)-106(8)5F(H)D  
WD(M)-126(8)0F(H)D/WD(M)-126(8)5F(H)D  
WD(M)-146(8)0F(H)D/WD(M)-146(8)5F(H)D  
WD-1061FD/WD-1261FD/WD-1266FD  
WD-1461FD/WD-1466FD  
WD-1288FHD/WD-1488FHD  
WD-1480(5)FDN/WD-1480(5)FDF**

---

# CONTENTS

1. SPECIFICATION.....	3
2. FEATURES & TECHNICAL EXPLANATION .....	4
3. PARTS IDENTIFICATION .....	6
4. INSTALLATION.....	7
5. OPERATION.....	10
6. WIRING DIAGRAM / PROGRAM CHART .....	16
7. TROUBLESHOOTING.....	18
7-1.BEFORE PERFORMING SERVICE .....	18
7-2.QC TEST MODE.....	18
7-3.HOW TO KNOW THE WATER LEVEL FREQUENCY.....	18
7-4.ERROR DISPLAY .....	19
8. ERROR DIAGNOSIS AND CHECK LIST .....	21
8-1. DIAGNOSIS AND ANSWER FOR ABNORMAL OPERATION.....	21
8-2. FAULT DIAGNOSIS AND TROUBLESHOOTING .....	24
9. DISASSEMBLY INSTRUCTIONS .....	30
10. EXPLODED VIEW AND PARTS LIST .....	37
10-1. THE EXPLODED VIEW OF CABINET ASSEMBLY .....	37
10-2. THE EXPLODED VIEW OF CONTROL PANEL AND DISPENSER ASSEMBLY .....	38
10-3. THE EXPLODED VIEW OF DRUM AND TUB ASSEMBLY .....	39
※ APPENDIX (Replacement parts list).....	40

# 1. SPECIFICATION

ITEM		WD(M)-1060F(H)D/WD(M)-1065F(H)D/WD(M)-1260F(H)D/ WD(M)-1265F(H)D/WD(M)-1460F(H)D/WD(M)-1465F(H)D	WD(M)-1080F(H)D/1085F(H)D/280F(H)D/1285F(H)D WD(M)-480F(H)D/1485F(H)D/WD-1061FD/1261FD/1266FD WD-1461FD/1466FD/1288FHD/1488FHD/1480(5)FDN/1480(5)FDF
POWER SUPPLY		220-240V~, 50Hz	
PRODUCT WEIGHT		65kg	
ELECTRICITY CONSUMPTION	WASHING	230W	
	SPIN (1400rpm)	440W	
	DRAIN MOTOR	38W	
	WASH HEATER	2000W	
REVOLUTION SPEED	WASH	45rpm	
	SPIN	1400 rpm : No spin/400/800/1000/1400 rpm	
		1200 rpm : No spin/400/800/1000/1200 rpm	
1000 rpm : No spin/400/600/800/1000 rpm			
OPERATION WATER PRESSURE		0.3-10kgf/cm <sup>2</sup> (30-1000kPa)	
CONTROL TYPE		Electronic	
WASH CAPACITY		7kg	
		Synthetic (4.0kg), Delicate (3.0kg), Wool (2.0kg)	
DIMENSION		600mm(W) × 600mm(D) × 850mm(H)	
WASH PROGRAM		Coloureds, Synthetic, Delicate, Wool, Rapid, Whites, Whites-Eco	Cotton-Eco, Cotton, Synthetic, Delicate, Wool, Hand Wash, Quick 30
RINSE		Super, Normal, Hold	
DOOR SWITCH TYPE		Bi-Metal type	
WATER LEVEL		9 steps (by sensor)	
RESERVATION		From 3 hours to 19 hours	
SENSING OF THE LAUNDRY AMOUNT		Adapted	
FUZZY LOGIC		Adapted	
DISPLAY OF THE REMAINING TIME		Adapted	
ERROR DIAGNOSIS		9 items	
POWER AUTO OFF		Adapted	
CHILD LOCK		Adapted	
AUTO RESTART		Adapted	
RAPID		Adapted	

## 2. FEATURES & TECHNICAL EXPLANATION

---

### 2-1.FEATURES



#### ■ Jumbo drum

LG's jumbo drum can wash about 40% more load than conventional washing machine. A bigger drum improves the wash performance.

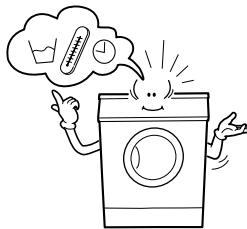

#### ■ More economical by Intelligent Wash System

Intelligent Wash System detects the amount of load and water temperature, and then determines the optimum water level and washing time to minimize energy and water consumption.

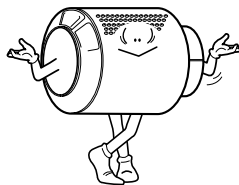

#### ■ Direct Drive system

The advanced Brushless DC motor rotates the Drum directly without belt and pulley.

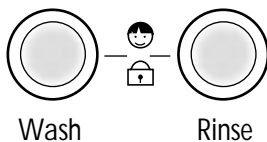

#### ■ Child-Lock

The Child-Lock system has been developed to prevent children from pressing any button to change the program during operation.

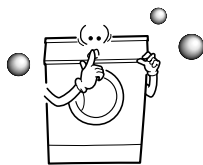

#### ■ Low noise speed control system

By sensing the amount of load and balance, automatical distributes load evenly to minimize the spinning noise level.



#### ■ Auto Restart

Although the washing machine is turned off by a power failure, it restarts automatically where it stopped when power is supplied again. And it will be the same the machine is unplugged and is plugged in again.

---

## 2-2.DETERMINE WASHING TIME BY FUZZY LOGIC

To get the best washing performance optimal time is determined by sensing of water temperature, selected washing temperature and laundry amount.

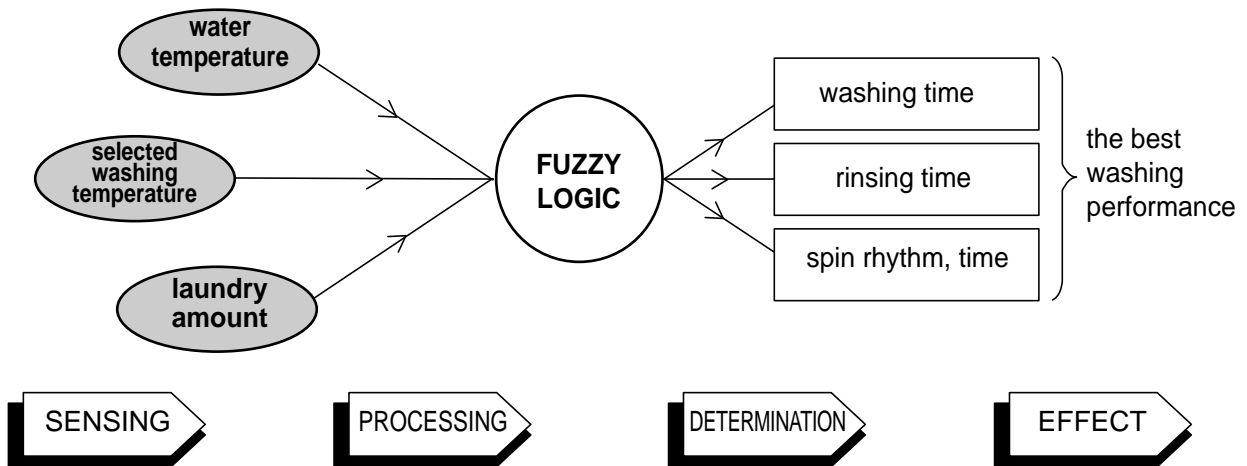

## 2-3.WATER LEVEL CONTROL

- This model adopts a pressure sensor which can sense the water level in the tub.
- Water supply is stopped when the water level to the preset level, then the washing program proceeds.
- Spinning does not proceed until the water in the tub reduces a certain level.

## 2-4.THE DOOR CAN NOT BE OPENED

- While program is operating.

### 3. PARTS IDENTIFICATION

---

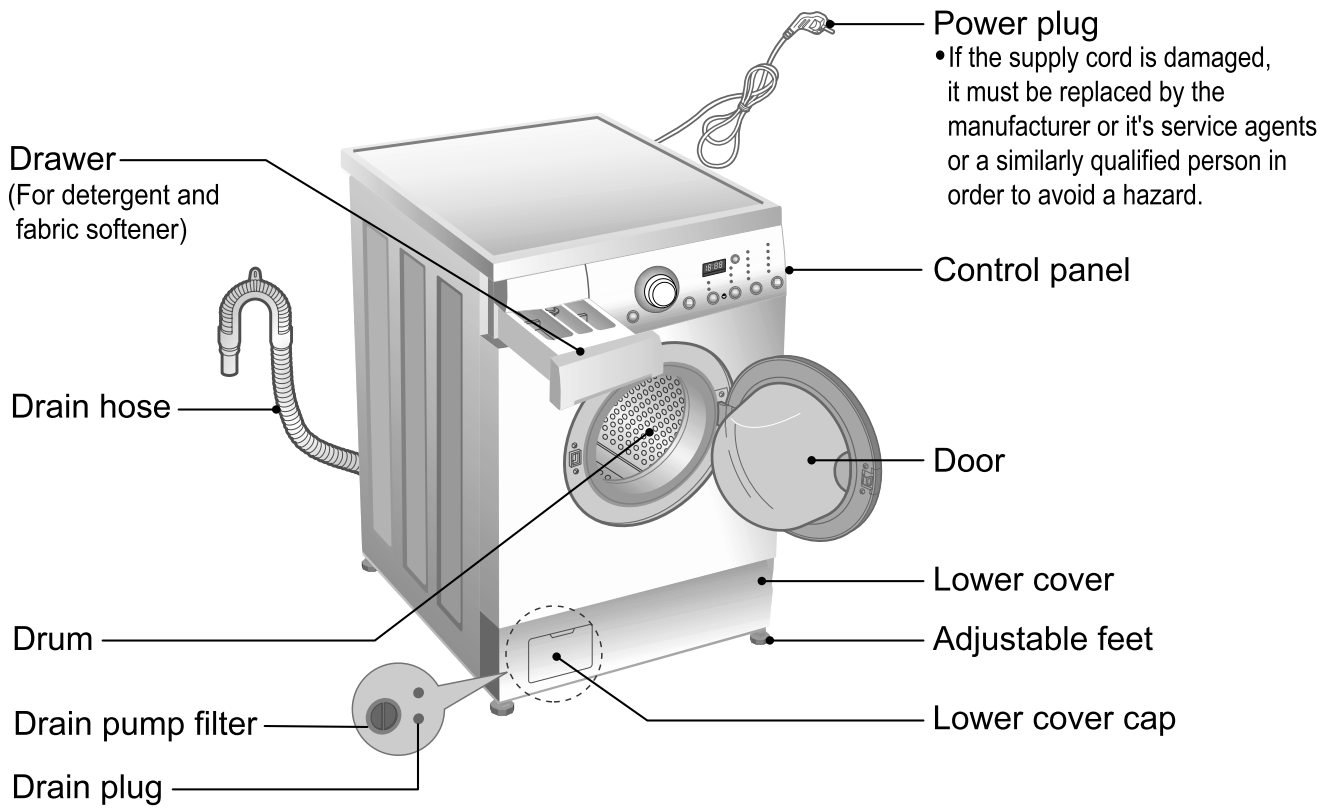

### ■ ACCESSORIES

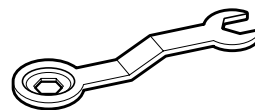
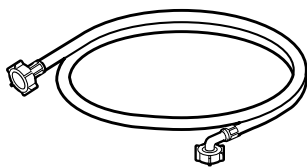

# 4. INSTALLATION

- 1 Before servicing ask the customer what the trouble is.
- 2 Check the adjustment (power supply is 220-240V~, remove the transit bolts....)
- 3 Check the troubles referring to the troubleshooting.
- 4 Decide service steps referring to disassembly instructions.
- 5 Then, service and repair.
- 6 After servicing, operate the appliance to see whether it works O-K or NOT.

## ■ STANDARD INSTALLATION

The appliance should be installed as follows.

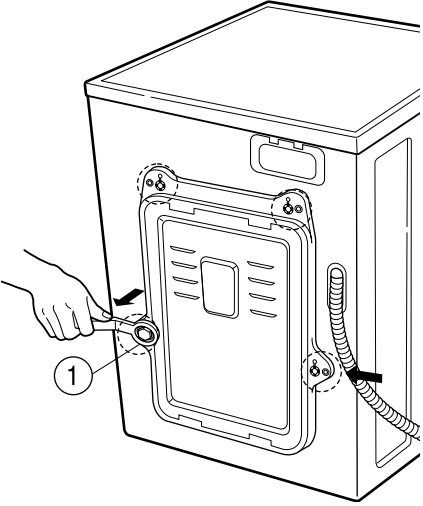
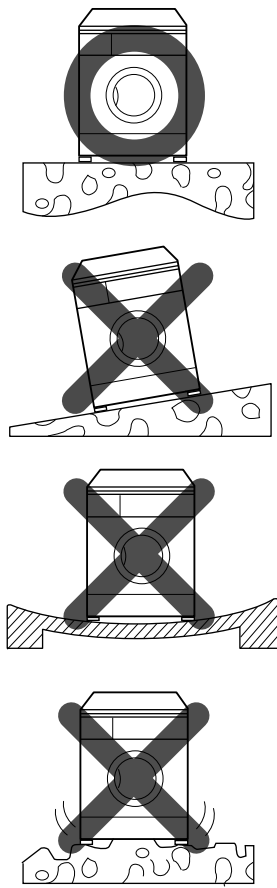
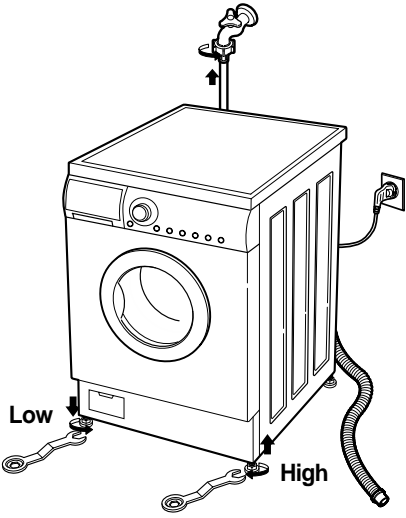
REMOVE THE TRANSIT BOLTS	INSTALL THE APPLIANCE ON FLAT AND FIRM SURFACE	ADJUST THE HORIZONTAL
<ul style="list-style-type: none"> <li>• Remove the transit bolts (4EA: ①) with supplied spanner.</li> <li>• Keep the transit bolts and spanner for future use.</li> <li>• Insert the 4 caps provided into the hole</li> </ul> 		<ul style="list-style-type: none"> <li>• Turn the leveling feet to set the appliance horizontally.</li> </ul>  <ul style="list-style-type: none"> <li>• The appliance goes up by rotating the feet clockwise.</li> <li>• The appliance comes down by rotating the feet counter-clockwise.</li> </ul>

## ■ HOW TO CONNECT INLET HOSE

- Check that the rubber washer is inside of the valve connector.
- Connect the inlet hose firmly to prevent leak.

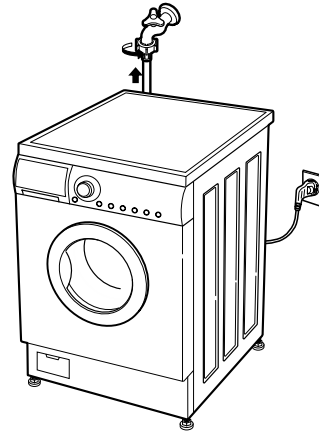

## ■ CONNECT DRAIN HOSE

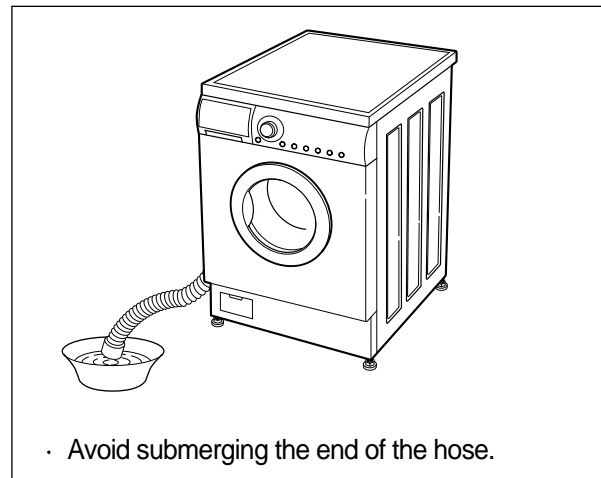
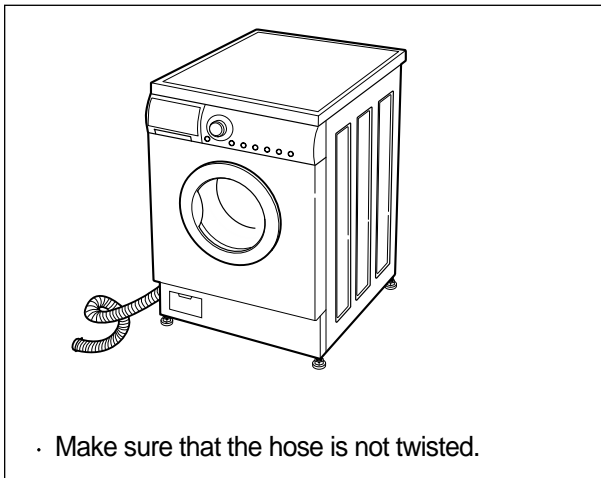

※ The drain hose should be placed under 100cm from the floor.

## ■ CONNECT POWER PLUG

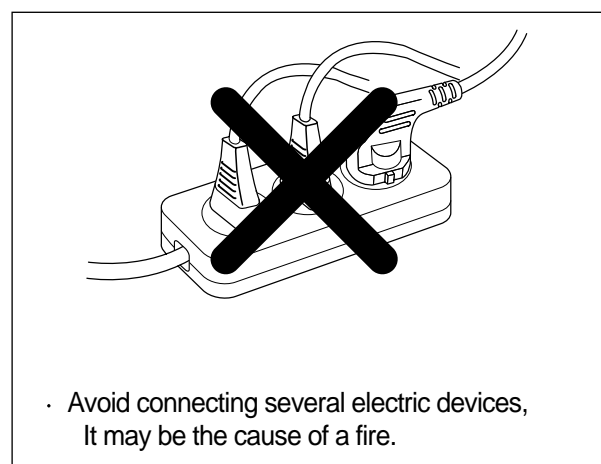
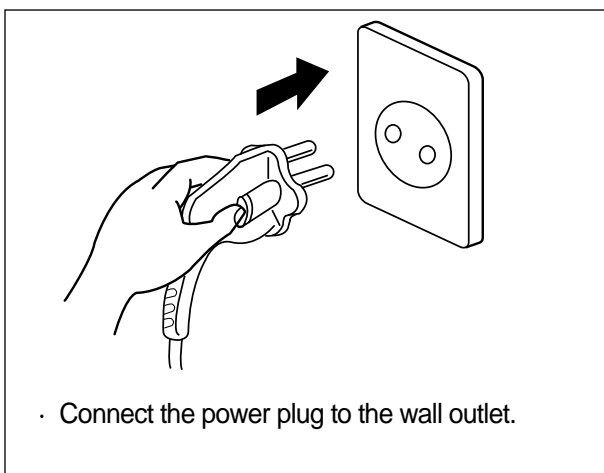



## 7 TEST OPERATION

**1** Preparation for washing.

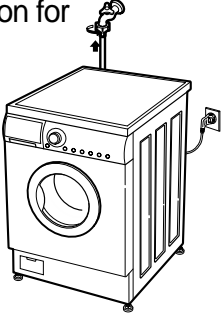

- Connect the power plug to the outlet.
- Connect the inlet hose.

**2** Press the power button.

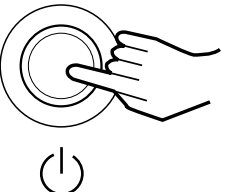

**3** Press the Start/Pause button.

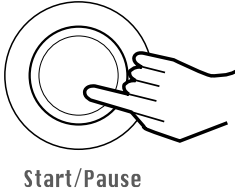

Start/Pause

- In case of coloureds program.

**6** Check the water heating.

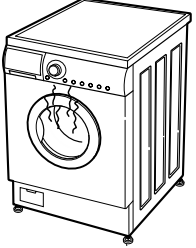

- Press the **Temp.** button and the present temperature will be displayed.

**5** Check automatic reverse turn.

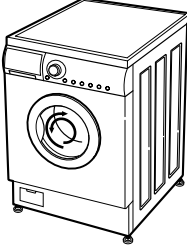

- Check if the drum rotates clockwise and counterclockwise.

**4** Check the water supply.

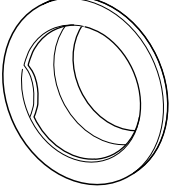

- Check if water is supplied through the detergent dispenser.

**7** Check drain and spin

- Turn off **Wash** and **Rinse** after pressing the **Start/Pause** button and start the machine again.
- Check drain and spin.

**8** Power off and open the door

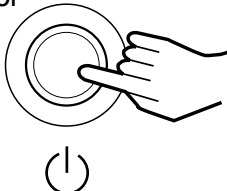

- Power off and then power on.
- Check if the door can be opened after 3 minutes.

**9** Water removal

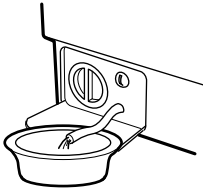

- If SVC is needed during check, remove the remaining water by pulling out the hose cap.

# 5. OPERATION

[WD(M)-1060F(H)D / 1065F(H)D / 1260F(H)D / 1265F(H)D / 1460F(H)D / 1465F(H)D]

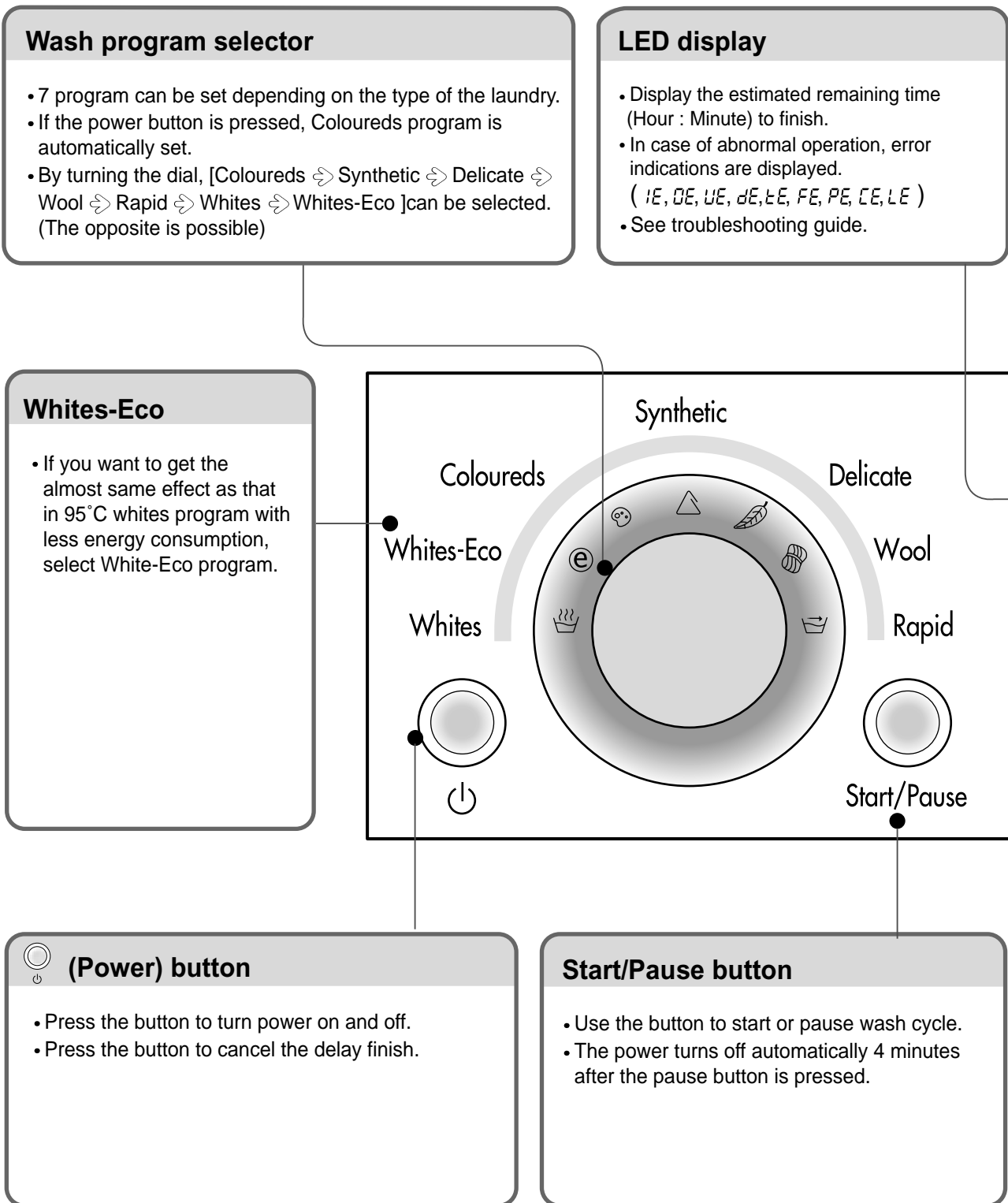

### Rinse hold

- If you desire to leave fabrics in the machine without spinning after rinse to prevent wrinkling, you may select rinse Hold by pressing the Rinse button.
- To drain and spin, press the Rinse button to turn off the Rinse Hold lamp.

### Time Delay

- Press the button when delayed washing is needed.
- When the button is pressed, 3:00 is displayed, maximum delay of 19:00 hours can be set.
- Each press advances time delay by the hour.
- Use [Power] button to cancel [Time Delay]
- [Time Delay] means the time required from the present to the completion of washing.

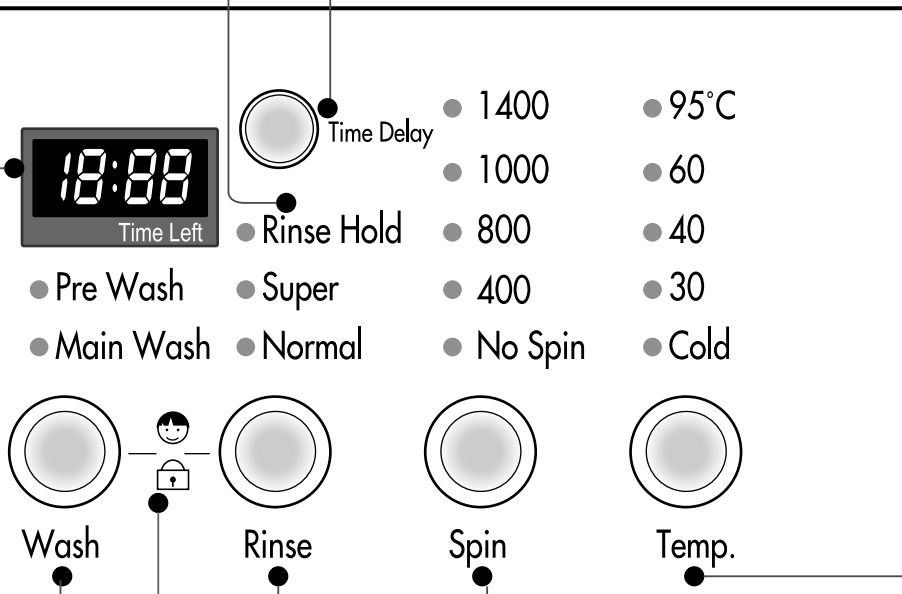

### Water temperature selector

- Press the button to select water temperature.
- The water temperature [40°C ⇄ 60°C ⇄ Cold ⇄ 30°C] can be selected in Coloureds or Synthetic.
- 95°C is selected for Whites only.
- By pressing the button while operating the washer, the present temperature is displayed.

### Child - Lock

- **Child Lock** system can be set and canceled by pressing and holding both [Wash] and [Rinse] button simultaneously more than 2 seconds.
- Once **Child Lock** is set, all buttons are inoperable.
- **Child Lock** system can be set anytime even during Power-off and operation.
- It is automatically cancelled when an operational error occur.

### For manual wash, rinse and spin speed

- Use these buttons to change wash/rinse/spin.
- When lamp is off, no selection has been made.
- Prewash is available for coloureds, whites, white-eco, and synthetic.

### Time Save

- It is possible in Cotton-Eco, Cotton, Synthetic, Delicate, Wool and Hand Wash programs.
- By selecting the Time Save option, the wash time may be reduced, depending on the program selected.

### LED display

- Display the estimated remaining time (Hour : Minute) to finish.
- In case of abnormal operation, error indications are displayed.  
( IE, DE, UE, dE, tE, FE, PE, CE, LE )
- See troubleshooting guide.

### Wash program selector

- 7 program can be set depending on the type of the laundry.
- If the power button is pressed, Whites program is automatically set.
- By turning the dial, [Cotton-Eco ⇄ Cotton ⇄ Synthetic ⇄ Delicate ⇄ Wool ⇄ Hand Wash ⇄ Quick 30] can be selected. (The opposite is possible)

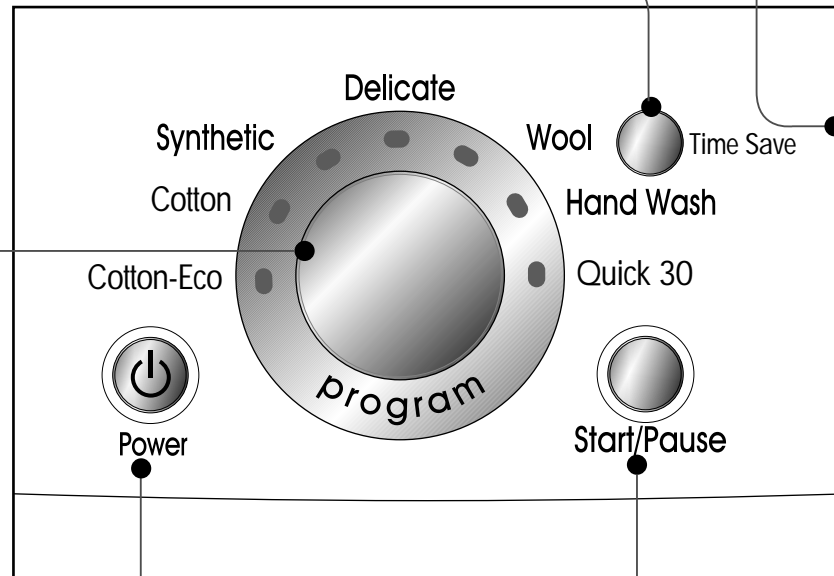

### (Power) button

- Press the button to turn power on and off.
- Press the button to cancel the delay finish.

### Start/Pause button

- Use the button to start or pause wash cycle.
- The power turns off automatically 4 minutes after the pause button is pressed.

## Rinse Hold

- If you desire to leave fabrics in the machine without spinning after rinse to prevent wrinkling, you may select Rinse Hold by pressing the Rinse button.
- To drain and spin, press the Rinse button to turn off the Rinse Hold lamp.

## Time Delay

- Press the button when delayed washing is needed.
- When the button is pressed, 3:00 is displayed, maximum delay of 19:00 hours can be set.
- Each press advances time delay by the hour.
- Use [Power] button to cancel [Time Delay]
- [Time Delay] means the time required from the present to the completion of washing.

## Water temperature selector

- Press the button to select water temperature.
- **Cotton-Eco:** 60°C ⇄ 40°C
- **Cotton:** 40°C ⇄ 60°C ⇄ 95°C ⇄ Cold ⇄ 30°C
- **Synthetic:** 40°C ⇄ 60°C ⇄ Cold ⇄ 30°C
- **Delicate, Wool, Quick 30 :** 30°C ⇄ 40°C ⇄ Cold.
- **Hand Wash :** Cold ⇄ 30°C ⇄ 40°C.
- 95°C is selected for Cotton only.
- By pressing the button while operating the washer, the present temperature is displayed.

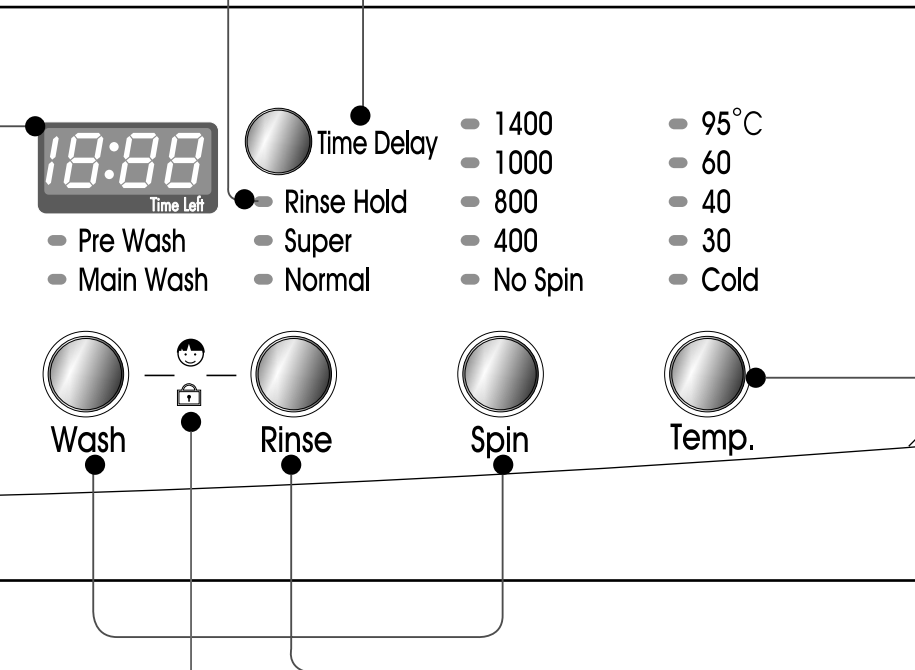

## Child - Lock

- **Child Lock** system can be set and canceled by pressing and holding both [Wash] and [Rinse] button simultaneously more than 2 seconds.
- Once **Child Lock** is set, all buttons are inoperable.
- **Child Lock** system can be set anytime even during Power-off and operation.
- It is automatically cancelled when an operational error occur.

## For manual wash, rinse and spin speed

- Use these buttons to change wash/rinse/spin.
- When lamp is off, no selection has been made.
- Prewash is available for Cotton-Eco, Cotton, Synthetic.

### Time Save

- It is possible in Cotton-Eco, Cotton, Synthetic, Delicate, Wool and Hand Wash programs.
- By selecting the Time Save option, the wash time may be reduced, depending on the program selected.

### LED display

- Display the estimated remaining time (Hour : Minute) to finish.
- In case of abnormal operation, error indications are displayed.  
( IE, OE, UE, dE, tE, FE, PE, CE, LE )
- See troubleshooting guide.

### Wash program selector

- 7 program can be set depending on the type of the laundry.
- If the power button is pressed, Whites program is automatically set.
- By turning the dial, [Cotton-Eco ⇄ Cotton ⇄ Synthetic ⇄ Delicate ⇄ Wool ⇄ Hand Wash ⇄ Quick 30] can be selected. (The opposite is possible)

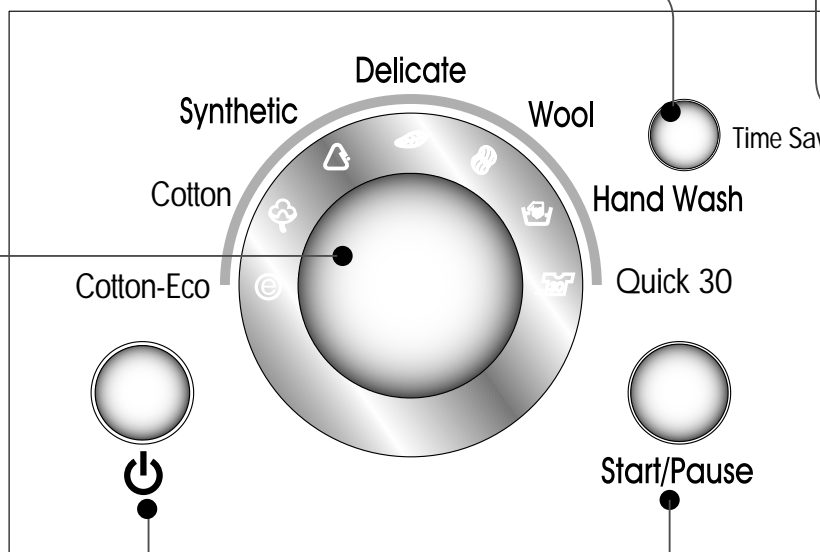

### (Power) button

- Press the button to turn power on and off.
- Press the button to cancel the delay finish.

### Start/Pause button

- Use the button to start or pause wash cycle.
- The power turns off automatically 4 minutes after the pause button is pressed.

## Rinse Hold

- If you desire to leave fabrics in the machine without spinning after rinse to prevent wrinkling, you may select Rinse Hold by pressing the Rinse button.
- To drain and spin, press the Rinse button to turn off the Rinse Hold lamp.

## Time Delay

- Press the button when delayed washing is needed.
- When the button is pressed, 3:00 is displayed, maximum delay of 19:00 hours can be set.
- Each press advances time delay by the hour.
- Use [Power] button to cancel [Time Delay]
- [Time Delay] means the time required from the present to the completion of washing.

## Water temperature selector

- Press the button to select water temperature.
- **Cotton-Eco:** 60°C ⇄ 40°C
- **Cotton:** 40°C ⇄ 60°C ⇄ 95°C ⇄ Cold ⇄ 30°C
- **Synthetic:** 40°C ⇄ 60°C ⇄ Cold ⇄ 30°C
- **Delicate, Wool, Quick 30 :** 30°C ⇄ 40°C ⇄ Cold.
- **Hand Wash :** Cold ⇄ 30°C ⇄ 40°C.
- 95°C is selected for Cotton only.
- By pressing the button while operating the washer, the present temperature is displayed.

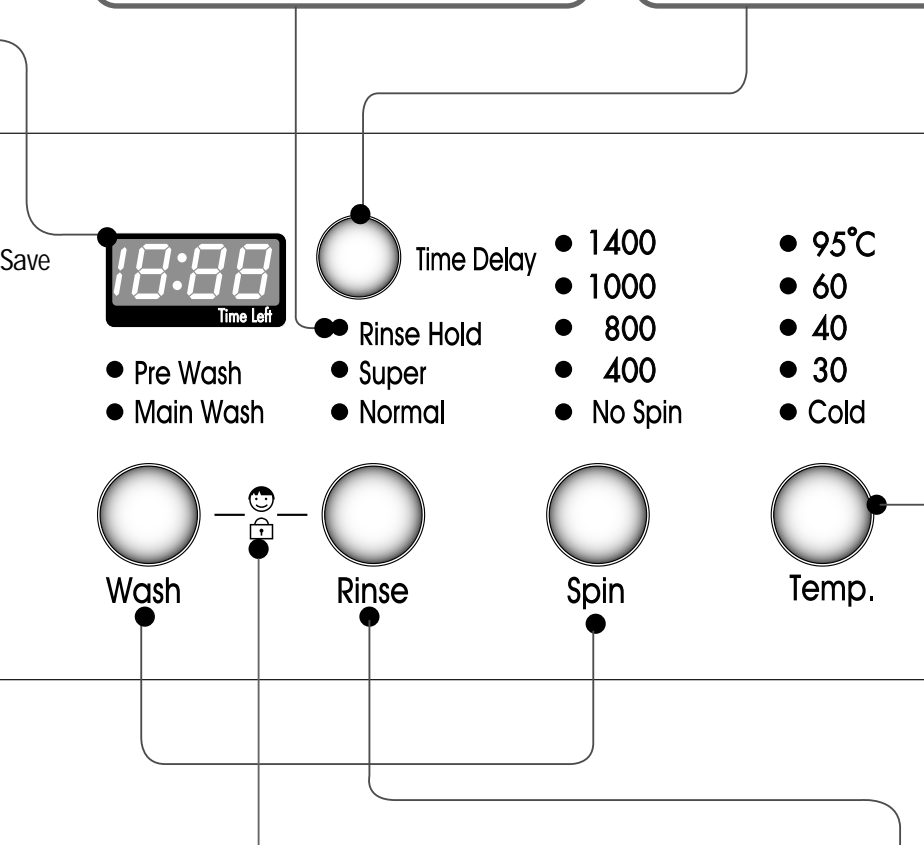

## Child - Lock

- **Child Lock** system can be set and canceled by pressing and holding both [Wash] and [Rinse] button simultaneously more than 2 seconds.
- Once **Child Lock** is set, all buttons are inoperable.
- **Child Lock** system can be set anytime even during Power-off and operation.
- It is automatically cancelled when an operational error occur.

## For manual wash, rinse and spin speed

- Use these buttons to change wash/rinse/spin.
- When lamp is off, no selection has been made.
- Prewash is available for Cotton-Eco, Cotton, Synthetic.

# 6. WIRING DIAGRAM / PROGRAM CHART

[WD(M)-1060F(H)D / 1065F(H)D / 1260F(H)D / 1265F(H)D / 1460F(H)D / 1465F(H)D]

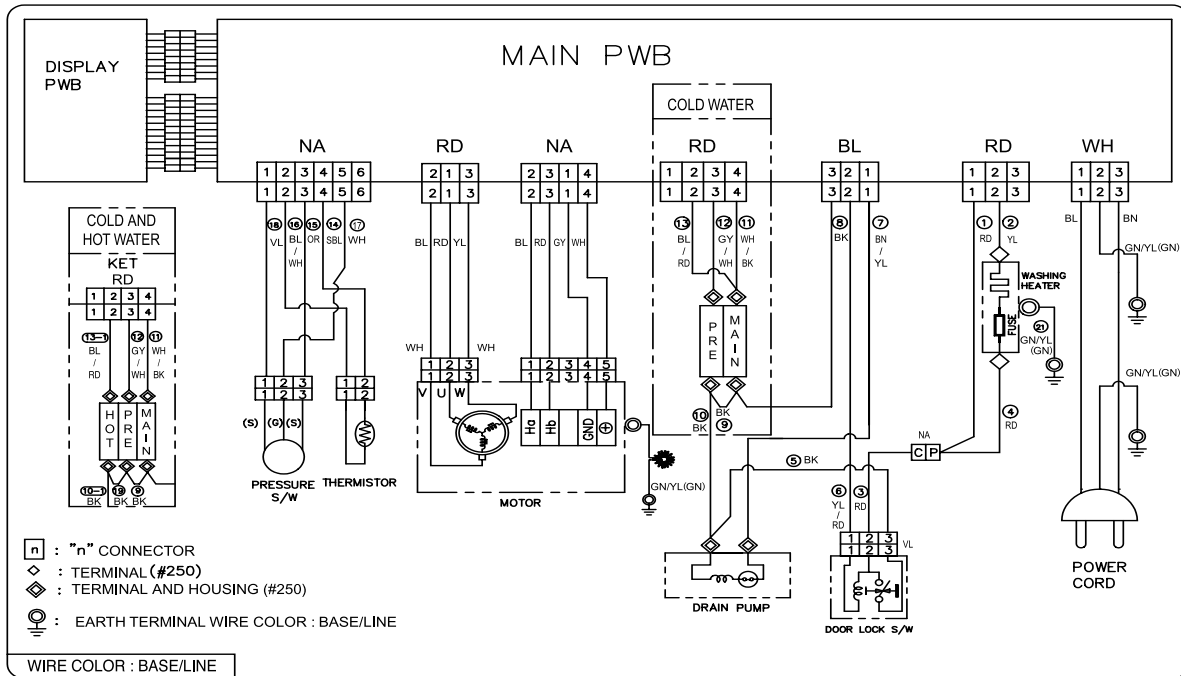

## PROGRAM CHART

\* Water Supply : W-S

\* Intermittent Spin : I-S

\* Disentangle : D-T

COURSE	CYCLE STEP	Wash										Rinse								Spin			END OFF	Normal Working Time (Hour:Minute)								
		Pre				Main						Normal (Hold)				Extra (Hold)				D-T	D-T	D-T										
		W.S	Wash	Drain	I.S	W.S	Washing Heat	Wash	W.S	Rinse	Drain	Drain	I.S	W.S	Rinse	Drain	I.S	W.S	Rinse						Drain	I.S	W.S	Rinse	Drain			
		1	2	3	4	5	6	7	8	9	10	11	12	13	14	15	16	17	18	19	20	21			22	23	24	25	26	27	28	29
	Time (SEC)	120	MIN	60	300	120					MIN	120	60	60	60	300	120	360	60	300	120	360	60	300	120	360	60	600	120	20	20	
	Coloureds	8					22					52																			20	About 1:59
	Whites	8					40					37																			20	About 2:42
	WhitesEco	8					67																								20	About 2:58
	Rapid						10																								20	About 54
	Delicate						25																								20	About 1:05
	Wool						15																								20	About 55
	Synthetic	8					22																								20	About 1:32
	Wash	8					52																								20	About 1:09
	Rinse																														20	About 39
	RinseHold																														20	About 39
	Spin																														20	About 12
	Wash + Rinse	8					22																								20	About 1:48
	Wash + Spin	8					52																								20	About 1:14
	Rinse + Spin						52																								20	About 50

\* **Basic Cycle**  
 \* **Optional Cycle**  
 \* Pre-Setting Time : Water Supply - 120 sec.  
 Drain - 60 sec.  
 \* ~ Time for varies as the temperature or the amount of laundry.

\* Basic time is minute in washing chart  
 \* The actual program time can be varied with the load amount, water temperature or ambient temperature.



**[WD(M)-1080F(H)D/1085F(H)D/1280F(H)D/1285F(H)D/1480F(H)D/1485F(H)D  
WD-1061FD/1261FD/1266FD/1461FD/1466FD/1288FHD/1488FHD/1480(5)FDN/1480(5)FDF]**

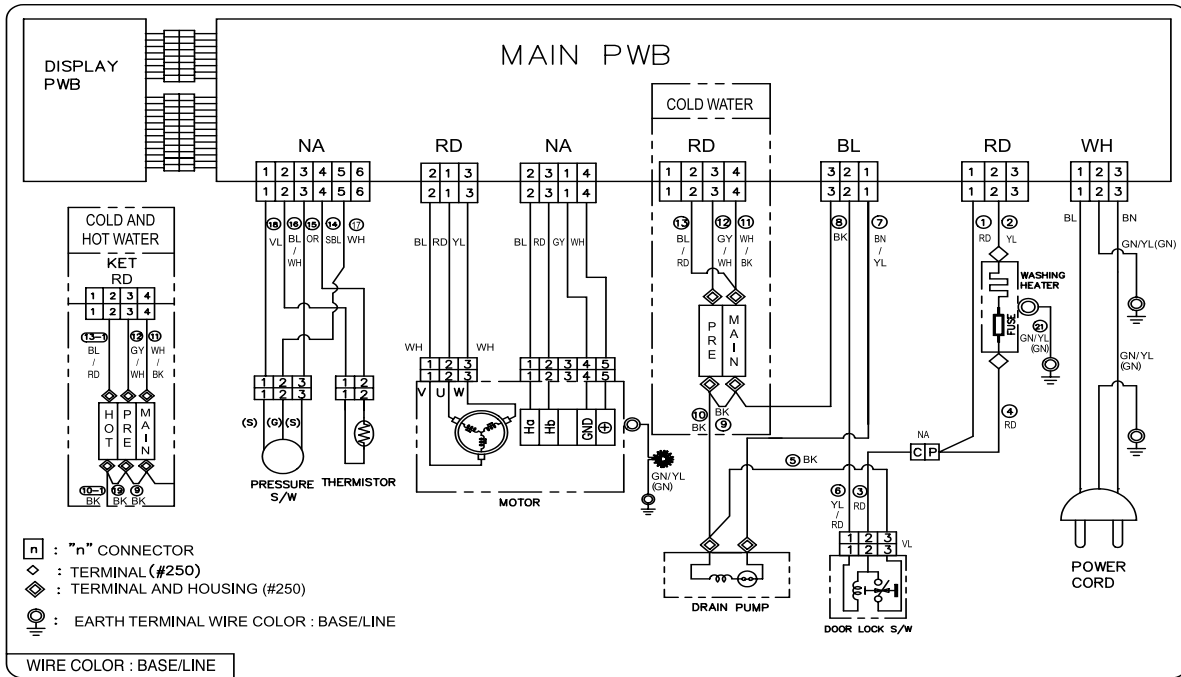

i ( ) : WD(M)-1080F(H)D / 1085F(H)D / 1280F(H)D / 1285F(H)D / WD-1061FD / WD-1261FD / 1266FD / 1288FHD  
PROGRAM CHART \* Water Supply : W·S \* Intermittent Spin : I·S \* Disentangle : D·T

COURSE	CYCLE STEP	Wash										Rinse										Spin			A U T O O F F	Normal Working Time (Hour:Minute)				
		Pre		Main				Normal (Hold)				Extra (Hold)		Spin		D·T	E N D													
		W·S	Washing	Drain	I·S	W·S	Washing Heat	Staycooling	W·S	Rinse	Drain	Drain	I·S	W·S	Rinse			Drain	I·S	W·S	Rinse	Drain	W·S	Rinse						
																											1	2	3	4
Time (SEC)	120	MIN	60	300	120	MIN	120	60	60	60	300	120	360	60	300	120	360	60	300	120	360	60	600	120	20	20				
Cotton	8					60																						20	20	About 2:43(2:39)
Cotton-Eco	8					96																								About 2:58
Synthetic	8					40																								About 1:32
Quick 30						23																								About 30
Delicate						59																								About 1:07
Wool						12																								About 1:01
HandWash						1																								About 1:00
Wash	8					29																								About 1:03
Rinse						1																								About 39
Rinse Hold						23																								About 39
Spin						29																								About 12
Wash + Rinse	8					60																								About 1:48
Wash + Spin	8					96																								About 1:14
Rinse + Spin						60																								About 38

\* Basic Cycle  
 \* Optional Cycle  
 \* Pre-Setting Time : Water Supply - 120 sec.  
 Drain - 60 sec.  
 \* ~ Time for varies as the temperature or the amount of laundry.

\* Basic time is minute in washing chart  
 \* The actual program time can be varied with the load amount, water temperature or ambient temperature

# 7. TROUBLESHOOTING

## 7-1.BEFORE PERFORMING SERVICE

- Be careful of electric shock or disconnecting the parts while troubleshooting.
- Voltage of each terminal in 220-240V~ and DC while applying an electric current.

## 7-2.QC TEST MODE.

- ① Pressing **Rinse**, and **Spin** button simultaneously.
- ② Power supply on with pressing upper two button.Then buzzer sound twice.
- ③ Press the Start/Pause button as follows.

[Press the Start/Pause button more 4 times until stop spinning]

Pressing number of [Start/Pause] button	Checking Point	Display Status
None	All lamps turn on	
1 time	Clockwise spin (right)	Drum rpm (About 40~52)
2 times	Low speed Spin	Drum rpm (About 55~65)
3 times	High speed Spin	Drum rpm (About 95~140)
4 times	Inlet valve for prewash operation	Water level frequency (25~65)
5 times	Inlet valve for mainwash operation	Water level frequency (25~65)
	Hot inlet valve in case of hot water fill	
6 times	Inlet valve for mainwash operation	Water level frequency (25~65)
7 times	Counterclockwise spin (left)	Drum rpm (About 40~52)
8 times	Heater is in operation for 3 sec.	Water temperature
9 times	Draining pump operation	Water level frequency
10 times	Auto off operation	

## 7-3.HOW TO KNOW THE WATER LEVEL FREQUENCY

\* Press the **Rinse** and **Spin** button simultaneously.

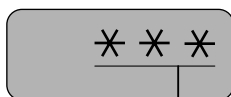









● The digits means water level frequency ( $10^{-1}$  kHz)

$$\begin{aligned} \text{ex) } 241 : \text{ Water level frequency} &= 241 \times 10^{-1} \text{ kHz} \\ &= 24.1 \text{ kHz} \end{aligned}$$

## 7-4.ERROR DISPLAY.







- If you press the Start/Pause button when an error is displayed, any error except **PE** will disappear and the machine will change into pause status.
- In case of **PE**, **LE**, **DE**, if the error is not resolved within 20 sec. In the case of other errors, if the error is not resolved within 4 min., power will be turned off automatically and the error only will be blinked. But in the case of **FE**, power will not be turned off.

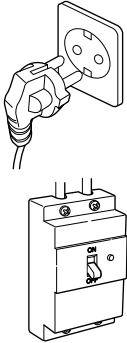

	ERROR	SYMPTOM	CAUSE
1	WATER INLET ERROR		<ul style="list-style-type: none"> <li>○ Water has not reached to the pre-set level within 8 min. since inlet valve operated, or water has not reached to the normal level within 25 min.</li> </ul>
2	IMBALANCE ERROR		<ul style="list-style-type: none"> <li>○ Load is too small.</li> <li>○ The appliance is tilted.</li> <li>○ Laundry is gathered to one side.</li> <li>○ Non-distributable things are put into the drum.</li> </ul>
3	DRAIN ERROR		<ul style="list-style-type: none"> <li>○ Water has not drained enough within 10 min.</li> </ul>
4	OVERFLOW ERROR		<ul style="list-style-type: none"> <li>○ Water is automatically being pumped out because too much water is in the tub.</li> </ul>
5	SENSOR PRESSURE S/W ERROR		<ul style="list-style-type: none"> <li>○ The sensor pressure switch is out of order.</li> </ul>
6	DOOR OPEN ERROR		<ul style="list-style-type: none"> <li>○ The Start/Pause button is pressed with the door open.</li> <li>○ The door switch is out of order.</li> </ul>
7	HEATING ERROR		<ul style="list-style-type: none"> <li>○ The THERMISTOR is out of order.</li> </ul>

	<b>ERROR</b>	<b>SYMPTOM</b>	<b>CAUSE</b>
<b>8</b>	CURRENT ERROR		<ul style="list-style-type: none"> <li>• MAIN PWB ASSEMBLY is out of order <ul style="list-style-type: none"> <li>☞ Replace the MAIN PWB ASSEMBLY</li> </ul> </li> <li>• Winding in the STATOR ASSEMBLY is short-circuited. <ul style="list-style-type: none"> <li>☞ Replace the STATOR ASSEMBLY</li> </ul> </li> </ul>
<b>9</b>	LOCK ERROR		<ul style="list-style-type: none"> <li>• The connector (3-pin, male, white) in the LEAD WIRE ASSEMBLY is not connected to the connector (3-pin, female, white) of STATOR ASSEMBLY. <ul style="list-style-type: none"> <li>☞ Reconnect or repair the connector</li> </ul> </li> <li>• The electric contact between the connectors [3-pin, male, white in the LEAD WIRE ASSEMBLY and 4-pin, female, natural in the MAIN PWB ASSEMBLY is bad or unstable. <ul style="list-style-type: none"> <li>☞ Reconnect or repair the contact in the connector</li> </ul> </li> <li>• The LEAD WIRE ASSEMBLY between the STATOR ASSEMBLY and MAIN PWB ASSEMBLY is cut (open circuited). <ul style="list-style-type: none"> <li>☞ Repair the damaged (open-circuited) the LEAD WIRE ASSEMBLY</li> </ul> </li> <li>• The hall sensor is out of order/defective. <ul style="list-style-type: none"> <li>☞ Replace the STATOR ASSEMBLY</li> </ul> </li> </ul>

# 8. ERROR DIAGNOSIS AND CHECK LIST

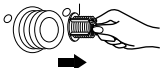
## 8-1. DIAGNOSIS AND ANSWER FOR ABNORMAL OPERATION

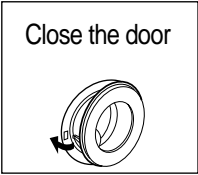
SYMPTOM	GUIDE FOR SERVICE CALL	
<p>NO POWER</p>	<p>Is the power plug connected firmly to 220-240V~ outlet?</p> <p style="text-align: center;"><b>YES</b></p> <p>Power failure? or Breaker opened? Is the outlet controlled by a switch</p> <p style="text-align: center;"><b>NO</b></p> <p style="text-align: center;">Visit to check</p>	
<p>WATER INLET TROUBLE</p> 	<p>Is  displayed?</p> <p style="text-align: center;"><b>YES</b></p> <p>Is the tap opened?</p> <p style="text-align: center;"><b>YES</b></p> <p>Is the tap frozen?</p> <p style="text-align: center;"><b>NO</b></p> <p>Is the water supply shut-off?</p> <p style="text-align: center;"><b>NO</b></p> <p>Is filter in the inlet valve clogged with foreign material?</p> <p style="text-align: center;"><b>NO</b></p> <p style="text-align: center;">Visit to check</p>	    <p style="text-align: center;"><b>YES</b></p> <p>Clean the filter of inlet valve</p> 

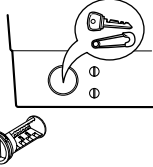
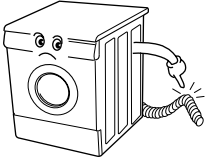
SYMPTOM	GUIDE FOR SERVICE CALL
<p>◦ DOOR OPEN ERROR</p> 	<p>Did you press the <b>Start/Pause</b> button when the door is open?</p> <p><b>YES</b> → Close the door</p>  <p><b>NO</b> → Visit to check</p> <p><b>Check if the door switch is O.K</b></p>
<p>◦ DRAIN TROUBLE</p> 	<p>Is  displayed?</p> <p><b>YES</b> → Is the debris filter clogged with foreign material such as pins, coins, etc?</p> <p><b>YES</b> → Clean up the filter.</p>  <p><b>NO</b> → Is the drain hose frozen with water, kinked, or crushed?</p> <p><b>NO</b> → Visit to check</p> 

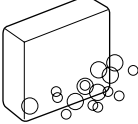
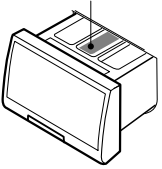
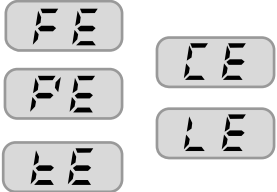
SYMPTOM	GUIDE FOR SERVICE CALL
<p>◦ Suds overflow from the appliance. (In this condition, wash and spin do not operate normally)</p>	<div style="display: flex; justify-content: space-between; align-items: center;"> <div style="width: 60%;"> <p>Is low-sudsing detergent for the drum washing machine used?</p> <p style="text-align: center;"><b>YES</b></p> <p>Is the proper amount of detergent used as recommended?</p> <p style="text-align: center;"><b>YES</b></p> <p>Recommend to reduce the amount of detergent.</p> <ul style="list-style-type: none"> <li>* This appliance has the automatic suds sensing function which operates under much suds condition for good rinse and preventing overflow.</li> <li>* When much suds are sensed, the suds removing function such as drain, water input, and pause will operate without rotating the drum.</li> </ul> </div> <div style="width: 35%; text-align: center;">  <p><b>LOW-SUDSING DETERGENT</b></p> </div> </div>
<p>◦ No effect of softener</p>	<div style="display: flex; justify-content: space-between; align-items: center;"> <div style="width: 60%;"> <p>Is softener put in the correct compartment of the drawer?</p> <p style="text-align: center;"><b>YES</b></p> <p>Is the drawer closed during wash?</p> <p style="text-align: center;"><b>YES</b></p> <p>Is the softener cap clogged?</p> <p style="text-align: center;"><b>YES</b></p> <p>Explain how to use softener</p> <p><b>Clean the compartment for softener</b></p> </div> <div style="width: 35%; text-align: center;"> <p>Compartment for softener</p>  </div> </div>
	<p style="text-align: center;">Visit to check</p>

## 8-2.FAULT DIAGNOSIS AND TROUBLESHOOTING

### CAUTION

1. Be careful of electric shock or disconnecting the parts while troubleshooting.
2. First of all, check the connection of each part terminal with wiring diagram.
3. If you replace the MAIN PWB ASSEMBLY, put in the connectors correctly.

### NO POWER

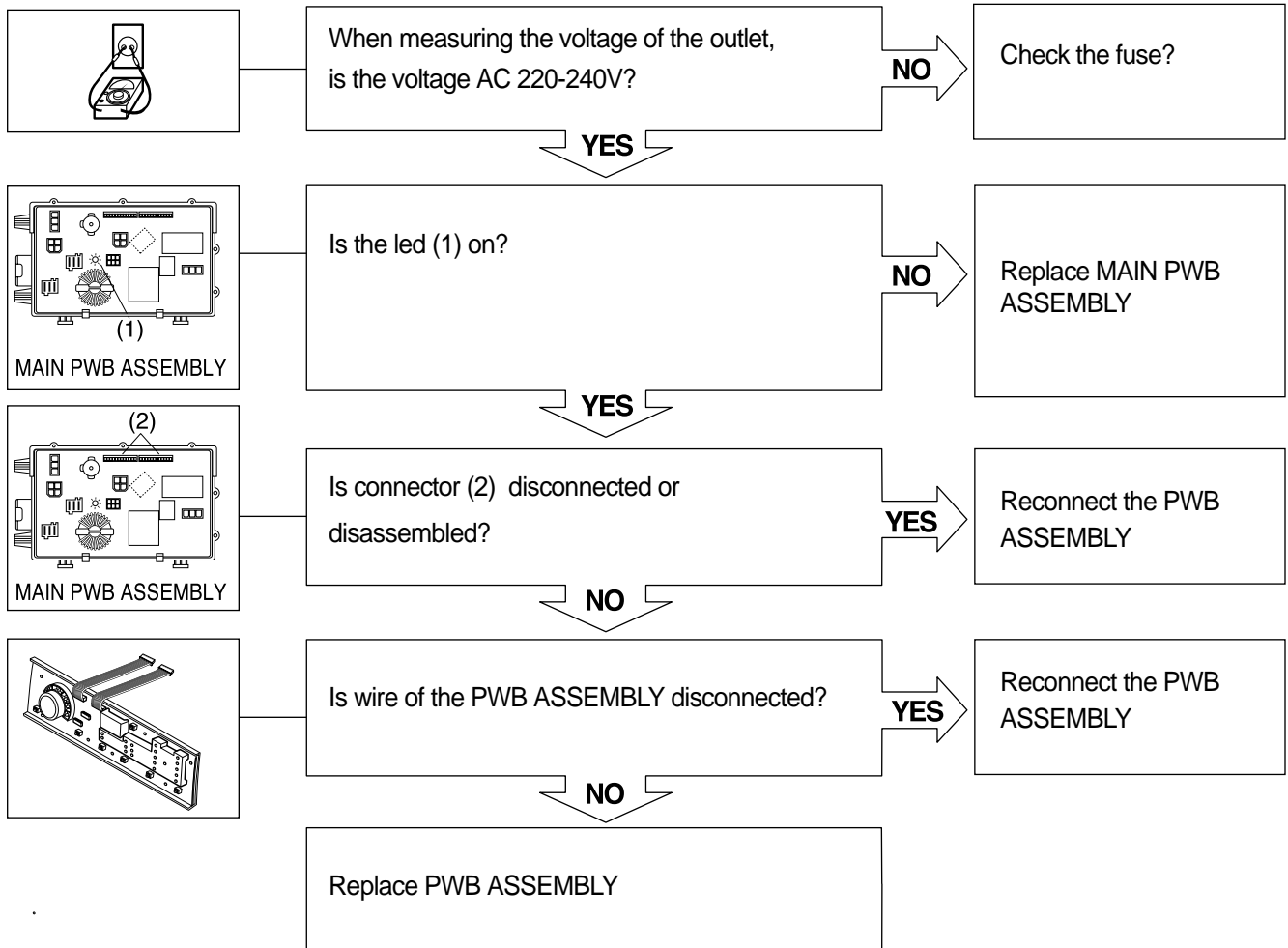



## NO WATER SUPPLY

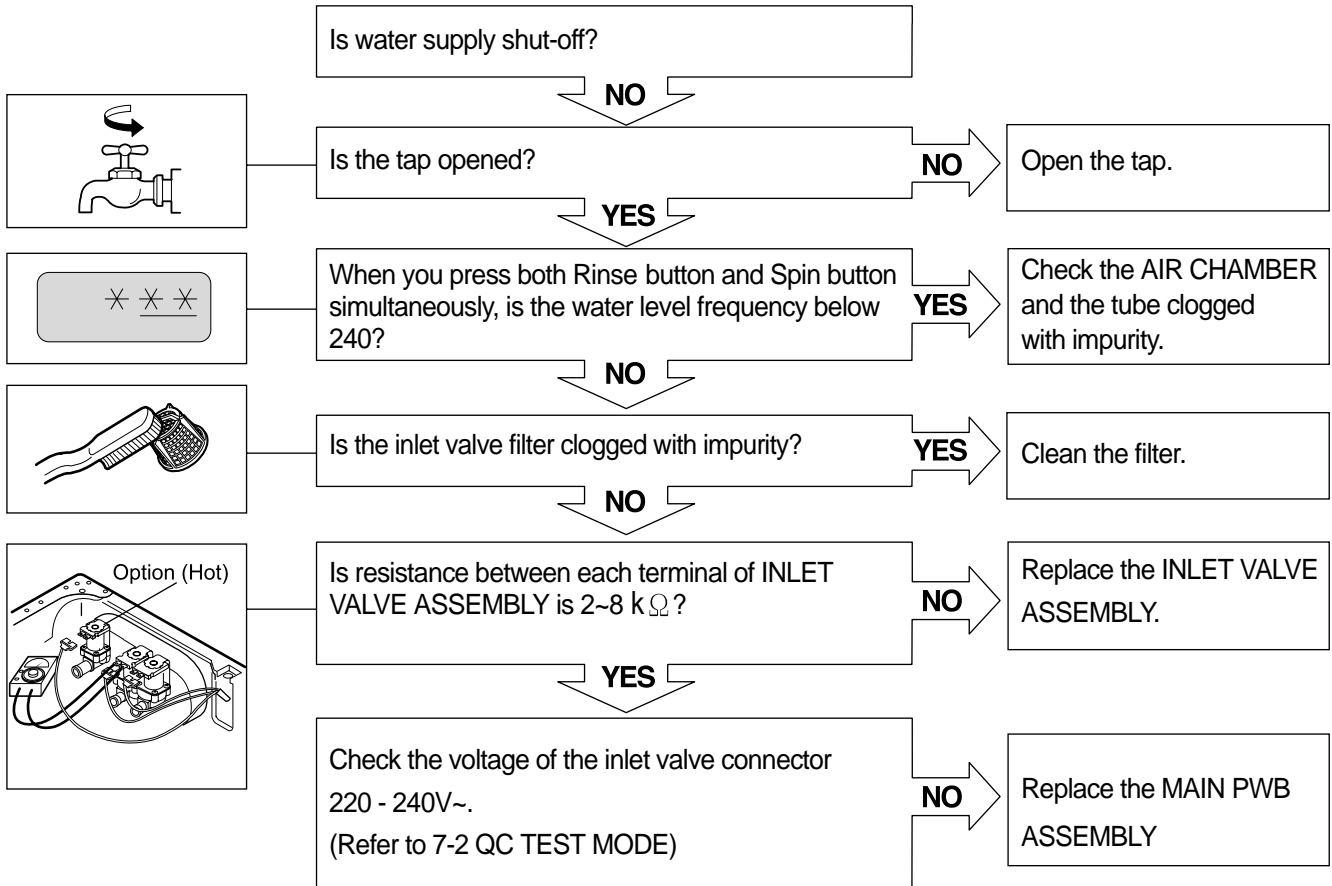

## DETERGENT DOES NOT FLOW IN

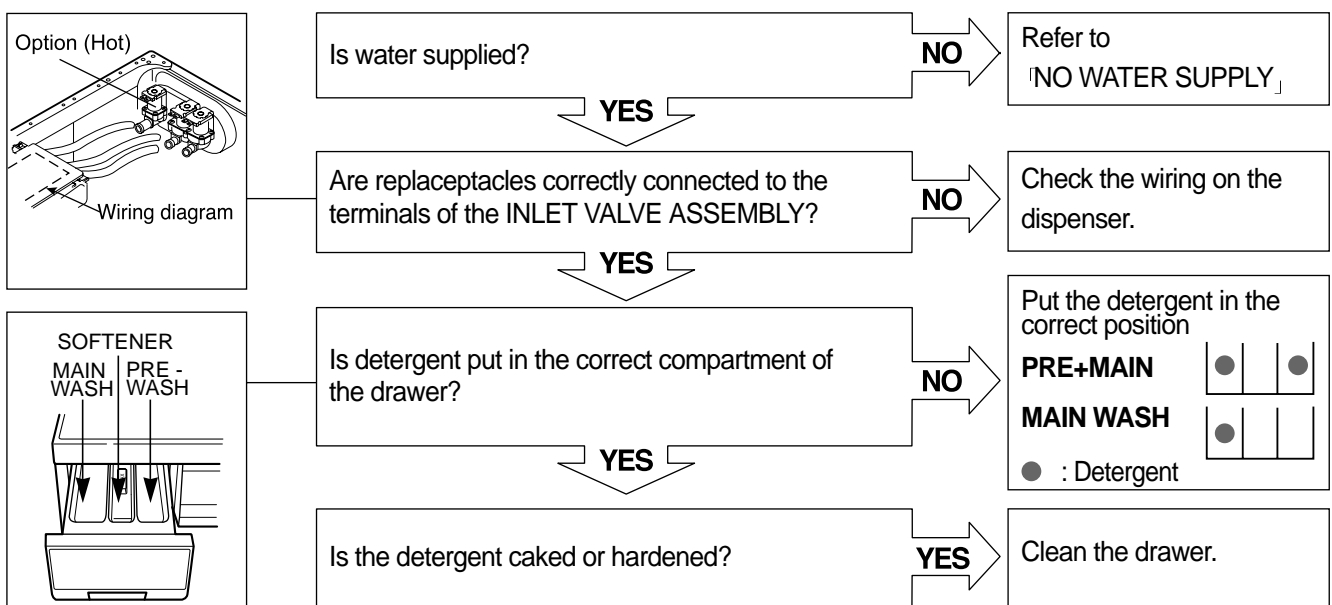

## SOFTENER DOES NOT FLOW IN

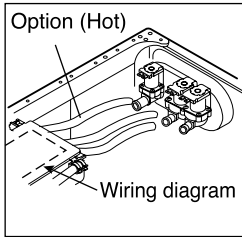

Is water supplied?

NO

Refer to  
「NO WATER SUPPLY」

YES

Are receptacles correctly connected to the terminals of the INLET VALVE ASSEMBLY?

NO

Check the wiring on the dispenser.

YES

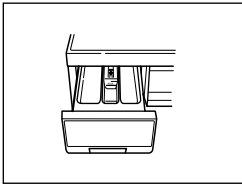

Is softener put in the correct compartment of the drawer?

NO

Put it in the correct compartment.

YES

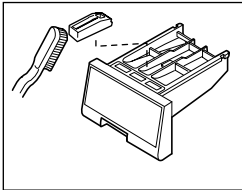

Is the softener cap clogged?

YES

Clean the cap and drawer.

## ABNORMAL SOUND

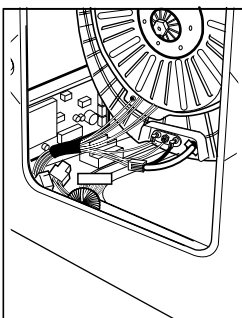

Is the motor bolt loosened?

YES

Fix the bolt tightly.

NO

Is there friction noise from the motor?

YES

Replace the STATOR ASSEMBLY or ROTOR ASSEMBLY.

## HEATING WITHOUT WATER

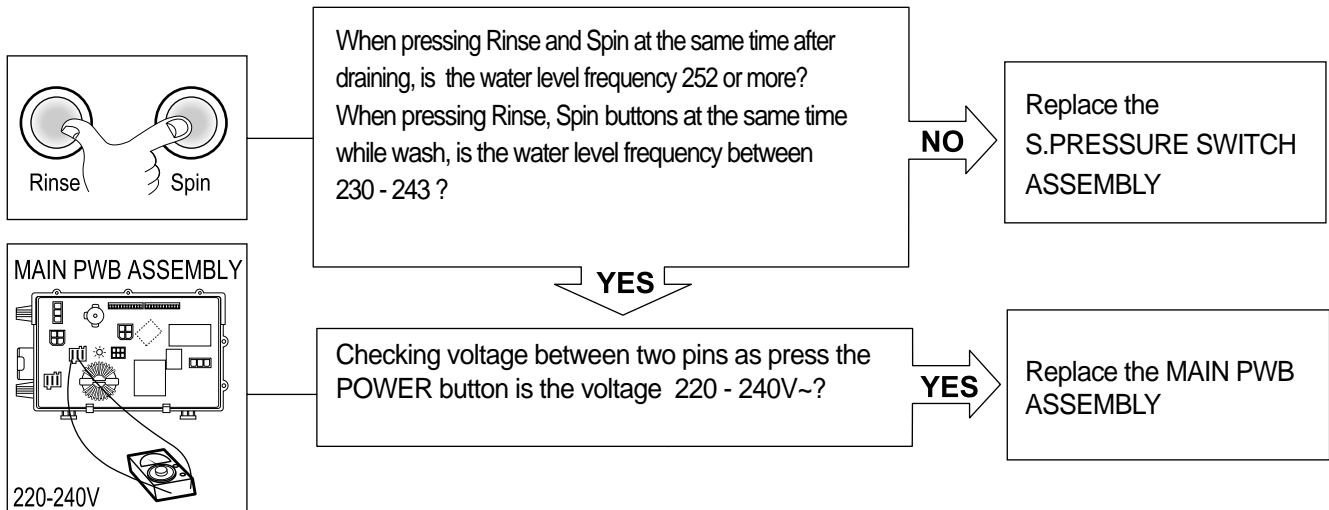

## DRAIN MALFUNCTIONING

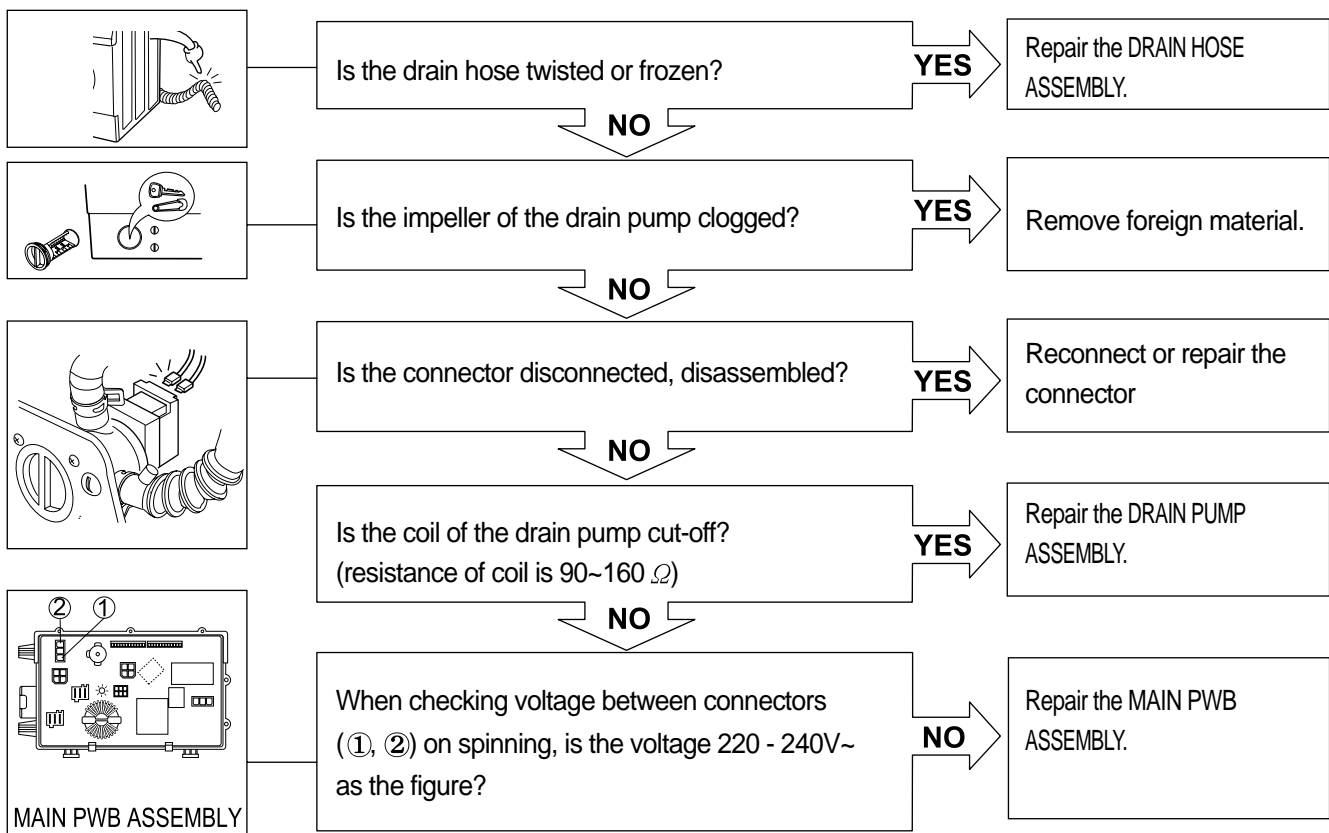

## WASH HEATER TROUBLE

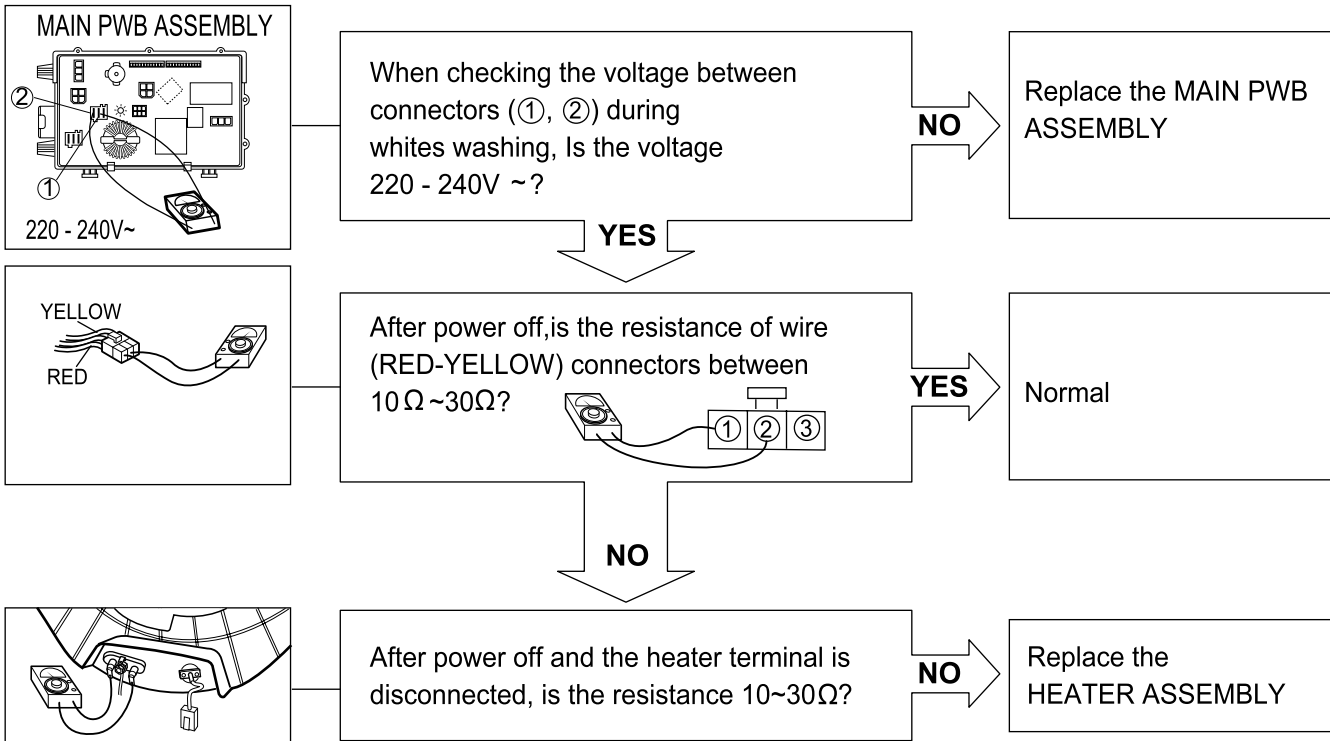

## HEATING CONTINUOUSLY ABOVE THE SETTING WATER TEMPERATURE

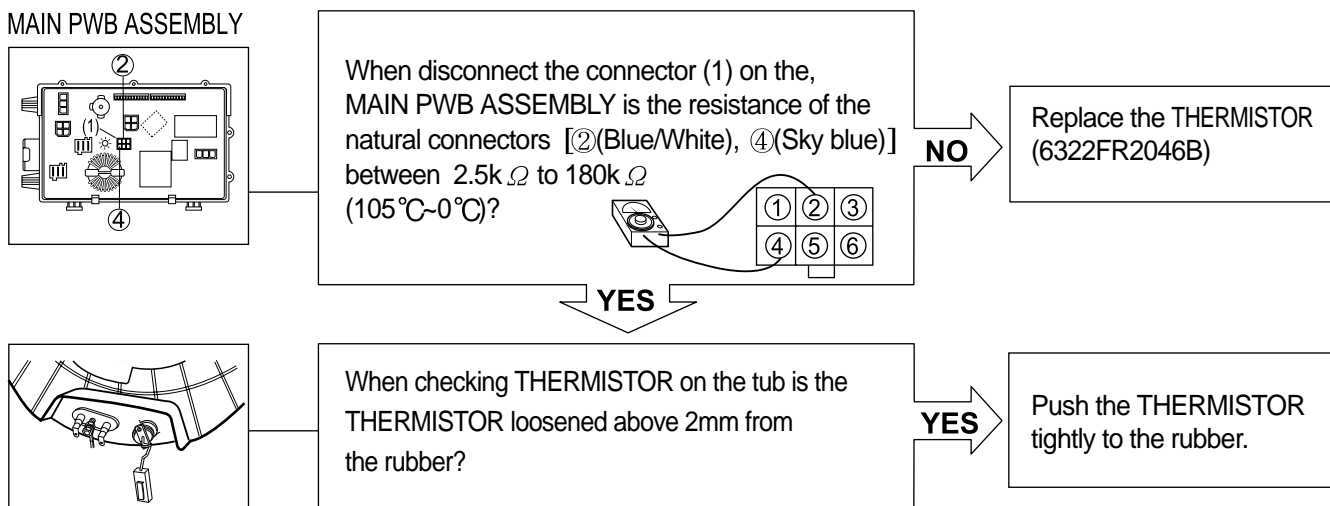

## SPIN TROUBLE

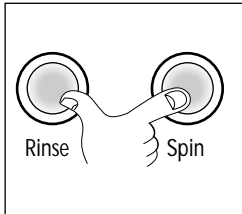

Check on the spinning, is the frequency of the water level 248 or more. The frequency can be checked by pressing the Rinse and Spin buttons at the same time on the program.

**NO**

Check the S.PRESSURE SWITCH ASSEMBLY or HOSE (Pressure). If the problem is on the S.PRESSURE SWITCH ASSEMBLY or the HOSE, replace the S.PRESSURE SWITCH ASSEMBLY or the HOSE.

**YES**

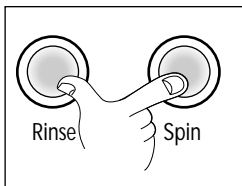

When pressing Rinse, Spin and POWER buttons at the same time after power off, press the Start/Pause button 2 times, is the drum spinning at low speed?

**YES**

Normal

**NO**

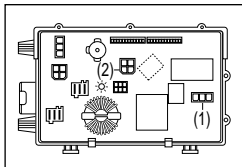

Is it disconnected, or disassembled?  
[Red:3pin (1), NA:4pin (2)]

**YES**

Correct the connector.

**NO**

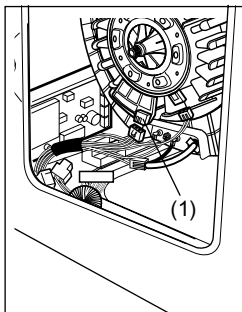

Check the motor connector, Is the resistance of the terminal same as the figure?

**MOTOR TERMINAL (1)**

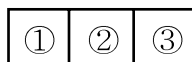

Resistance of terminal:

①~② / ②~③ / ③~① : About 5 Ω ~10 Ω

**NO**

Replace the STATOR ASSEMBLY (4417FA1994E)

**YES**

Replace the MAIN PWB ASSEMBLY

# 9. DISASSEMBLY INSTRUCTIONS

\* Be sure to unplug the machine out of the outlet before disassembling and repairing the parts.

## CONTROL PANEL ASSEMBLY

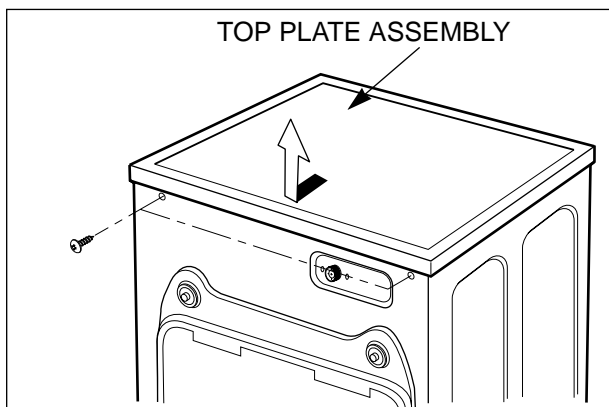

- ① Unscrew 2 screws on the back of the top plate.
- ② Pull the top plate backward and upward as shown.

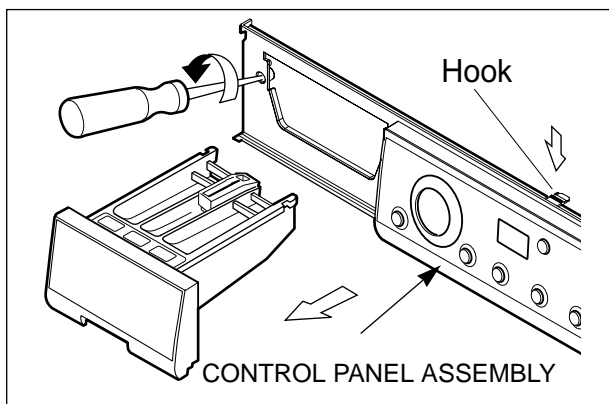

- ① Disconnect the ASSEMBLY connector.
- ② Pull out the drawer and unscrew 3 screws.
- ③ Push 2 upper hooks down and pull the control panel.

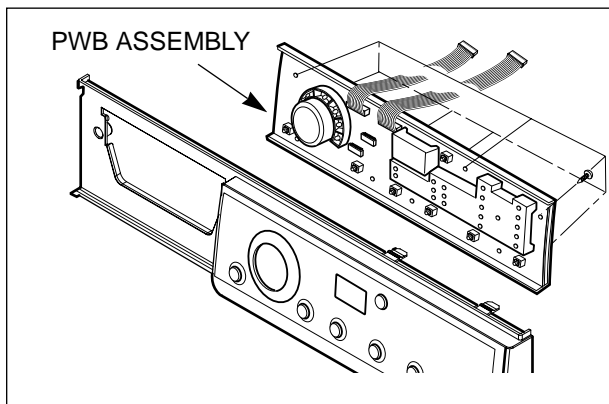

- ① Disconnect the PWB ASSEMBLY from the control panel by unscrewing 9 screws.

## DISPENSER ASSEMBLY

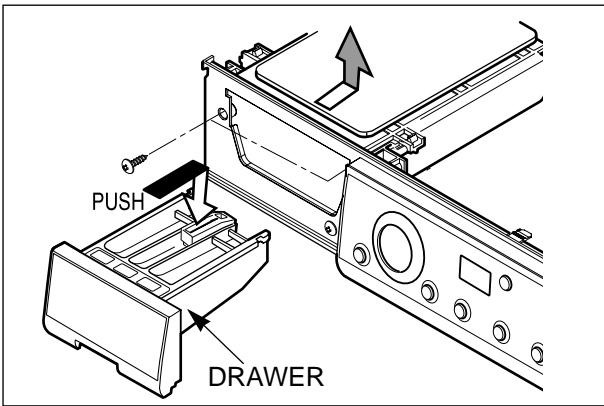

- ① Disassemble the TOP PLATE ASSEMBLY.
- ② Pull out the drawer slightly upward.
- ③ Unscrew 2 screws.

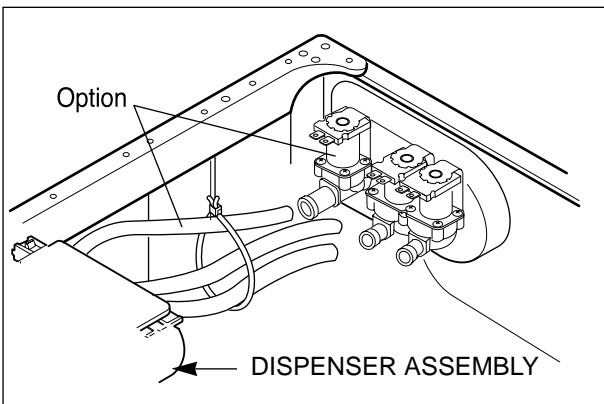

- ① Disassemble hose clamps and hoses.
- ② Disassemble the ventilation bellows and the water inlet bellows from the tub.

## INLET VALVE ASSEMBLY

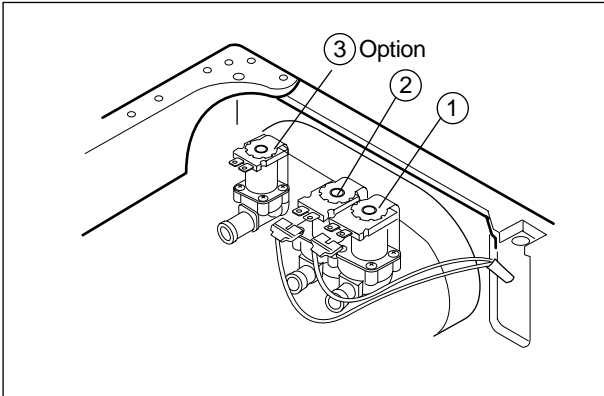

- ① Disconnect the wiring connector.
- ② Unscrew 2 screws from the back.

\* When reconnecting the connector

\* Cold only model

VALVE#1 (MAIN)	Whited/Black-Black
VALVE#2 (PRE)	Gray/ White - Black

\* Cold and Hot model

VALVE #1 (MAIN)	Whited/Black-Black
VALVE #2 (PRE)	Gray/ White - Black
VALVE #3 (HOT)	Blue/Red - Black

## MAIN PWB ASSEMBLY

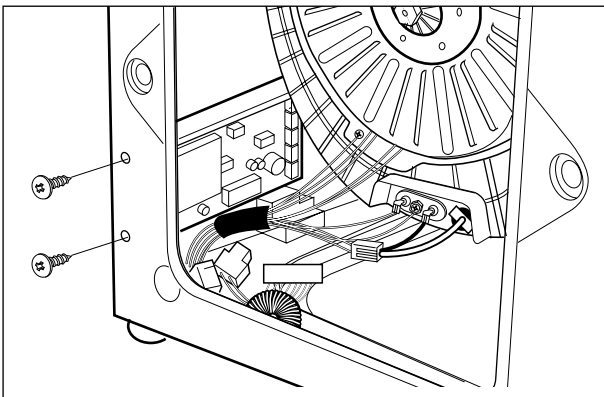

- ① Remove the back cover.
- ② Unscrew 2 screws.
- ③ Pull the MAIN PWB ASSEMBLY as shown.

## LOWER COVER

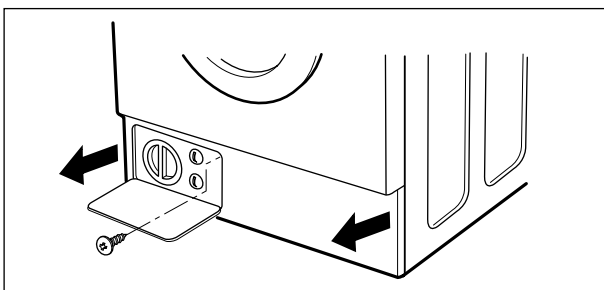

- ① Open the lower cover CAP by using coin and pull out the lower cover in the arrow direction after a screw is unscrewed.



## DOOR ASSEMBLY

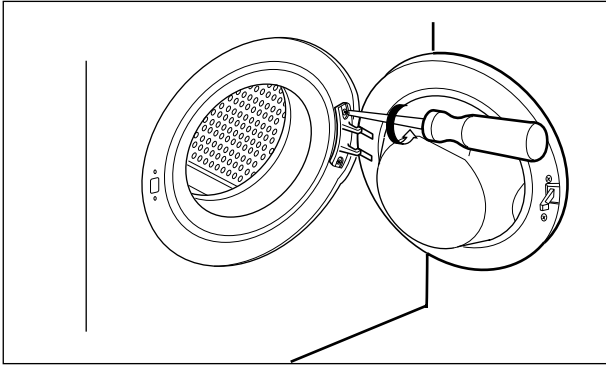

- ① Open the door completely.
- ② Remove the two screws from the hinge.

※ When removing the DOOR ASSEMBLY, it is necessary to hold the BRACKET that is inner of the CABINET COVER.

## GASKET

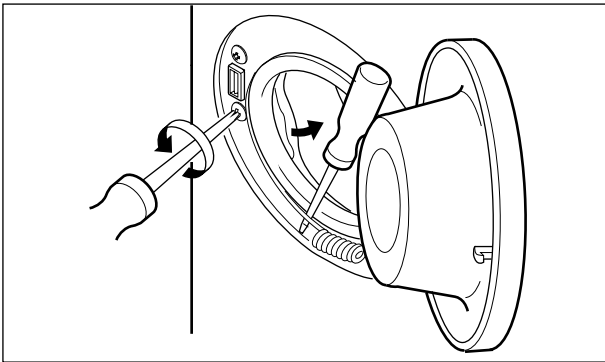

- ① Take apart the CLAMP ASSEMBLY (cabinet).
- ② Unscrew 2 screws from the CABINET COVER.
- ③ Open the lower cover cap and unscrew 1 screw inside
- ④ Take apart the LOWER COVER.

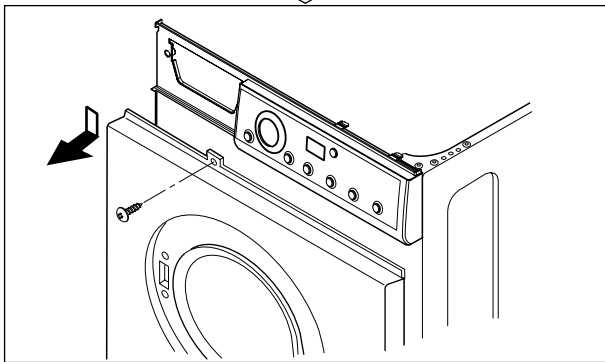

- ① Unscrew all the screws on the upper and lower sides of the CABINET COVER.

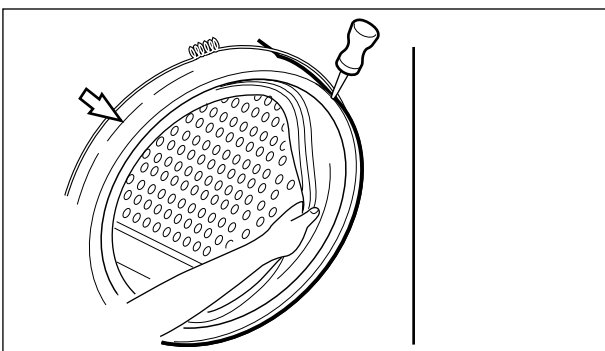

- ① Take apart the tub CLAMP ASSEMBLY
  - ② Make sure that the drain hole of the GASKET is put beneath when reassembling the GASKET.
- ※ Refer to the arrow mark on the TUB COVER.

## ROTOR ASSEMBLY, STATOR ASSEMBLY, FRICTION DAMPER ASSEMBLY

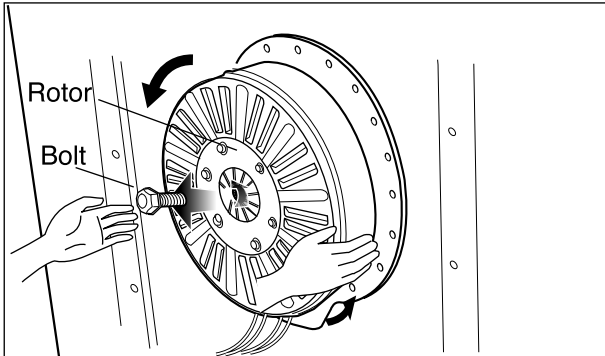

(ROTOR ASSEMBLY)

- ① Remove the BACK COVER.
- ② Unscrew the bolt to pull out the ROTOR ASSEMBLY.

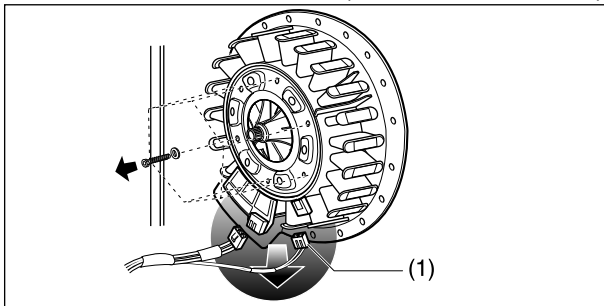

(STATOR ASSEMBLY)

- ① Disconnect the wiring connector.
- ② Unscrew 6 bolts from the STATOR.
- ③ Remove the BODY FRAME.  
(Only 1400 rpm models)

\* Note : Hook of connector (1) is on the backside

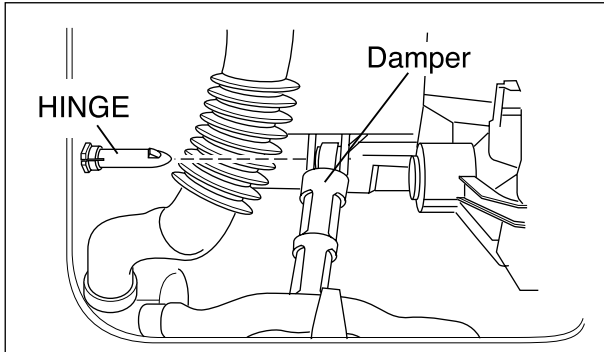

(FRICTION DAMPER ASSEMBLY)

- ① Pull out the HINGE, pressing its snap.
- ② Do not use the pulled out HINGE again  
It may be taken off during operation.

### ■ Clean the drain pump filter

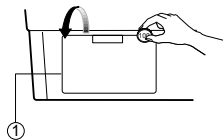

Open the lower cover cap ( ① )  
by using coin.

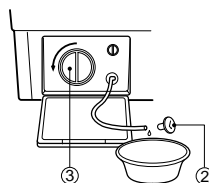

Unplug the drain plug ( ② ), then  
the water flows out,  
At this time use a vessel  
to prevent water flowing on the  
floor. If the water does not flow any  
more, turn the pump filter ( ③ )  
open to the left.

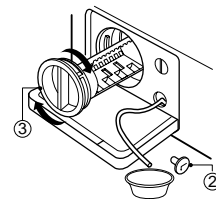

Take out any foreign material  
from the pump filter ( ③ ). After  
cleaning, turn the pump filter ( ③ )  
clockwise and insert the  
drain plug ( ② ) to the original  
place. close the lower cover cap.

## DRAIN PUMP ASSEMBLY

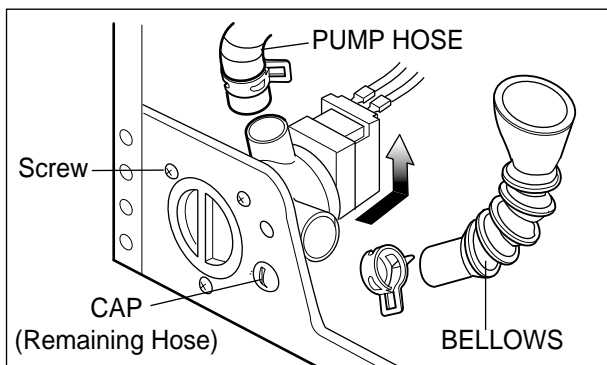

- ① Remove PUMP HOSE.
- ② Remove BELLOWS..
- ③ Remove CAP (Remaining Hose.)
- ④ Disconnect the wiring.
- ⑤ Unscrew 3 screws
- ⑥ Remove the DRAIN PUMP ASSEMBLY.

## HEATER ASSEMBLY

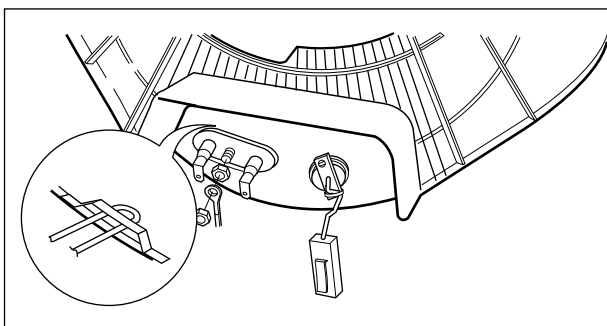

- ① Loosen the M6 heater nuts to pull out the HEATER ASSEMBLY.

### CAUTION

When mounting the HEATER ASSEMBLY be sure to insert the HEATER ASSEMBLY into the heater clip on the bottom of the tub.

## THERMISTOR

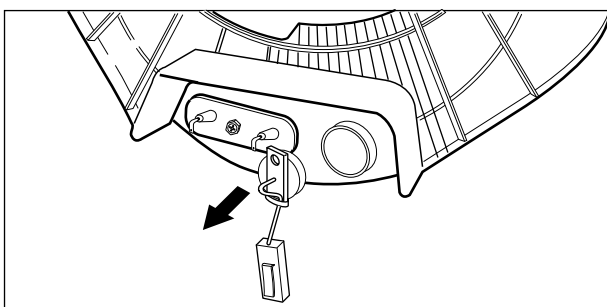

- ① Pull it out by holding the THERMISTOR bracket.
  - \* If it is pulled by the wire, it may be broken.
- ② When mounting the THERMISTOR again, make sure that it is got back tight to the bushing.

## SWITCH ASSEMBLY, DOOR LOCK

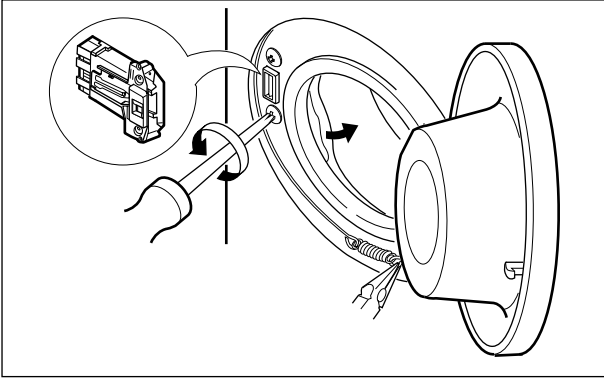

- ① Take apart the CLAMP ASSEMBLY (cabinet) and release the GASKET.
- ② Unscrew 2 screws holding the DOOR SWITCH ASSEMBLY.
- ③ Disconnect the door lock from the wiring connector.

## WHEN FOREIGN MATERIAL IS STUCK BETWEEN DRUM AND TUB

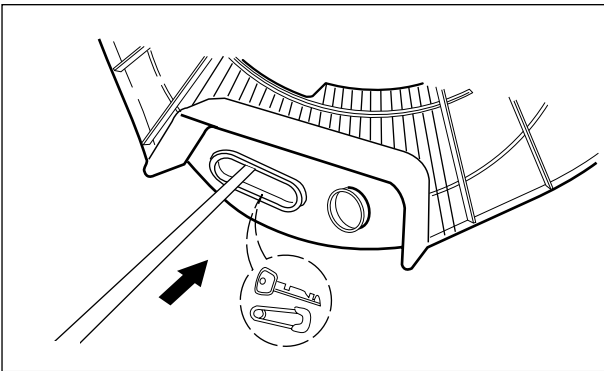

- ① Remove the HEATER ASSEMBLY.
- ② Remove the foreign material (wire, coin and others) by inserting a long bar through the hole.

# 10. EXPLODED VIEW AND PART LIST

## 10-1. THE PART LIST OF CABINET ASSEMBLY

○ : Service Part

○ : Non-Service Part

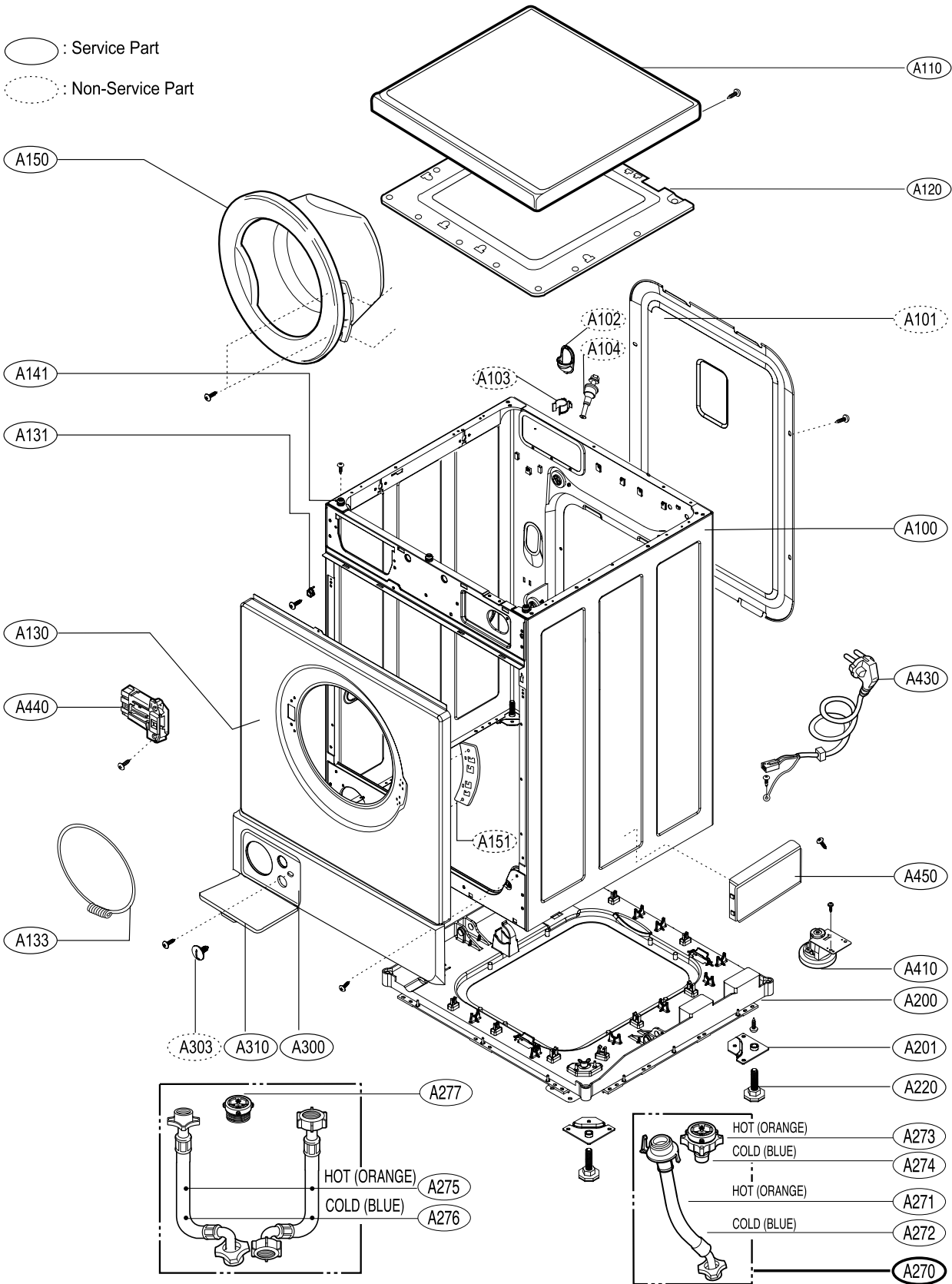

# 10-2 THE EXPLODED VIEW OF CONTROL PANEL & DISPENSER ASSEMBLY

○ : Service Part

⋯ : Non-Service Part

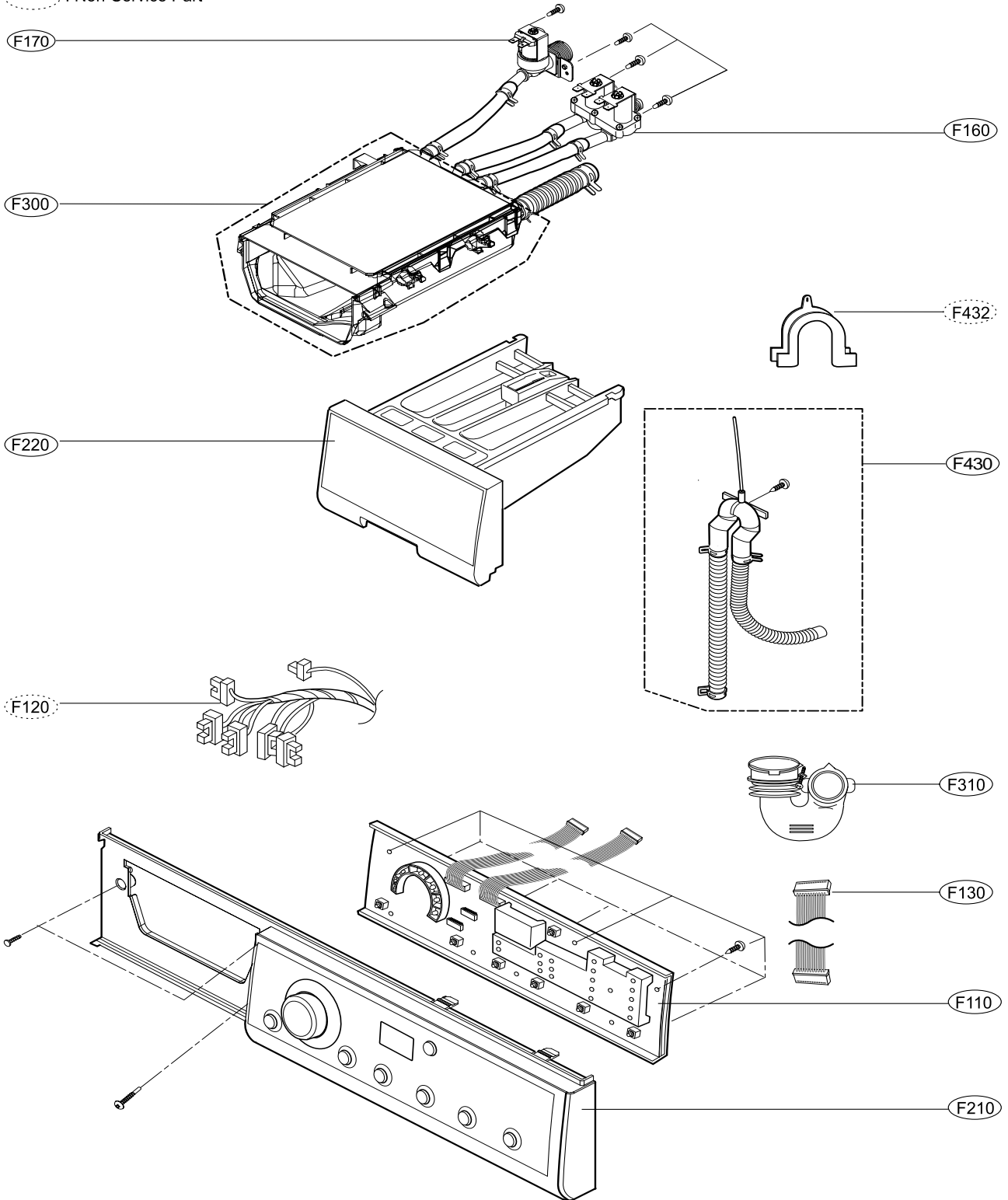

# 10-3 THE EXPLODED VIEW OF DRUM & TUB ASSEMBLY

○ : Service Part

○ : Non-Service Part

