



Philips Domestic Appliances and Personal Care

Service Manual

PRODUCT INFORMATION

- This product meets the requirements regarding interference suppression on radio and TV.
- After the product has been repaired, it should function properly and has to meet the safety requirements as officially laid down at this moment.

TECHNICAL INFORMATION

- Voltage : 100-240 V 50/60 Hz
- Power consumption : Motor depending
- Motor voltage : 54 V $\overline{\text{---}}$
- Power system : Mains
- Shaving heads : HQ5+ - 4222 036 05451
- SAP coding : HQ5426

DISASSEMBLY- AND RE-ASSEMBLY ADVISE

- Remove shaving unit, to prevent damages during repairs.
- Remove the screws A1 (2 x).
- Remove cover. (see Fig. 1)
- To remove the trimmer, first disassemble the trimmer slide by pushing down the locking pegs (2 x "X" in exploded view) and move the slide slightly outwards.
- Make room between trimmer and cover with a small screwdriver ("Y" in exploded view).
- Remove screws B1 (2 x).
- The PC-board with motor and hairchamber can now be removed from the housing.
- Detach the motor clamping springs (item 16) on the bearing block with a small screwdriver.

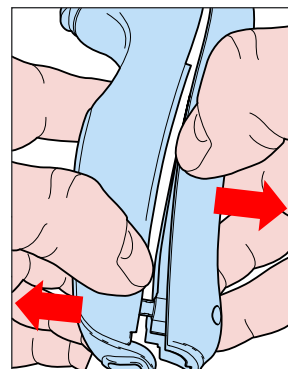

Fig. 1

REPAIR INSTRUCTION

- No specific issues

OPTIONAL (accessories)

- Pouch - 4222 036 05570

EXPLODED VIEW & PARTS LIST

HQ5426

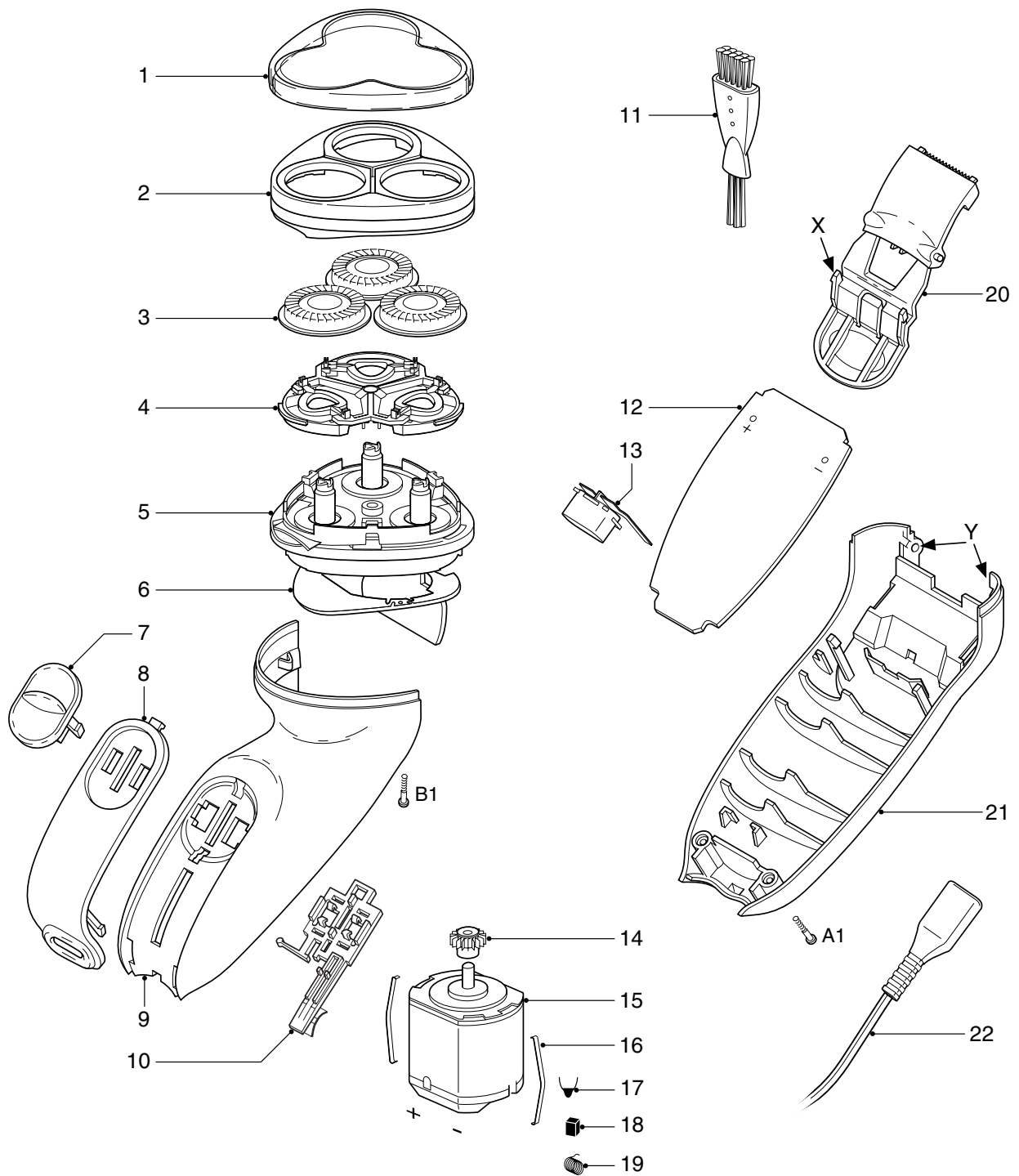

Pos	Service code	Description
1	4222 036 05430	protecting cap
2	4222 036 05440	bracket
3	4222 036 05450	HQ5+ shaving head
4	4222 036 05460	holder assy
5	4222 036 05420	hair chamber complete
6	4822 466 10937	dust seal
7	4222 036 05470	on/off knob
8	4222 036 05480	panel
9	4222 036 05500	housing
10	4222 036 05510	on/off slide assy
11	4822 479 30183	cleaning brush
12	4222 036 05540	printed circuit board
13	4222 036 05550	inlet
14	4822 522 33605	pinion

Pos	Service code	Description
15	4822 361 30455	motor assy
16	4822 492 71735	motor spring
17	4222 036 05520	capacitor Y5P 470 pF
18	4822 362 40181	carbon brush
19	4822 492 62703	spring
20	4222 036 05530	trimmer assy
21	4222 036 05560	cover
22	4822 321 10095	flex assy
	4822 321 10096	flex assy
	4822 321 10148	flex assy
	4222 036 01590	flex assy
	4822 502 30526	screw (torx-slot)
	4222 036 05570	pouch

■ = changed