

Service
Service
Service



Service Manual



TABLE OF CONTENTS

	Page
Location of pc boards & Version variations	1-2
Technical Specifications	1-3
Measurement setup	1-4
Service Aids, Safety Instruction, etc.	1-5
Disassembly Instructions & Service positions	2
Service Test Programs	3-1
Set Block diagram	4-1
Set Wiring diagram	5-1
Front Board	6
ECO6 Tuner Board: System Non-Cenelec	7A
System Cenelec	7B
Mains Board	8
Combi & Regulator Boards	9
Universal Loader	10
Set Mechanical Exploded view & parts list	11

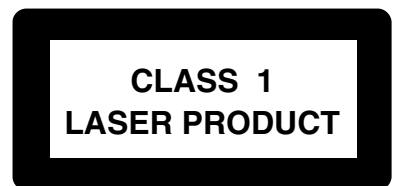

© Copyright 2003 Philips Consumer Electronics B.V. Eindhoven, The Netherlands
All rights reserved. No part of this publication may be reproduced, stored in a retrieval system or transmitted, in any form or by any means, electronic, mechanical, photocopying, or otherwise without the prior permission of Philips.

Published by BB 0302 Service Audio Printed in The Netherlands Subject to modification



3139 785 30260

Version 1.0



PHILIPS

SPECIFICATIONS

GENERAL:

Mains voltage : 110-127V/220-240V Switchable for /21/21M
 120V for /37
 220-230V for /22

Mains frequency : 50/60Hz

Power consumption : < 0.5W at ECO Power Standby
 : <15W at Standby (DEMO mode off)
 : 80W at Active

Clock accuracy : < 4 seconds per day

Dimension centre unit : 175 x 244 x 366mm

TUNER:

FM

Tuning range : 87.5-108MHz

Grid : 50kHz
 100kHz for /37

IF frequency : 10.7MHz \pm 25kHz

Aerial input : 75 Ω coaxial
 300 Ω click fit for /37

Sensitivity at 26dB S/N : < 7 μ V

Selectivity at 600kHz bandwidth : > 25dB

Image rejection : > 25dB

Distortion at RF=1mV, dev. 75kHz : < 3%

-3dB Limiting point : < 8 μ V

Crosstalk at RF=1mV, dev. 40kHz : > 18dB

MW

Tuning range : 531-1602kHz
 530-1700kHz for /21/21M/37

Grid : 9kHz
 10kHz for /21/21M/37

IF frequency : 450kHz \pm 1kHz

Aerial input : Frame aerial

Sensitivity at 26dB S/N : < 4.0mV/M

Selectivity at 18kHz bandwidth : > 18dB

IF rejection : > 45dB

Image rejection : > 28dB

Distortion at RF=50mV, m=80% : < 5%

LW

Tuning range : 153-279kHz /22

Grid : 3kHz

IF frequency : 450kHz \pm 1kHz

Aerial input : Frame aerial

Sensitivity at 26dB S/N : [< 6.0mV/M]

Selectivity at 18kHz bandwidth : [> 24dB]

IF rejection : [> 45dB]

Image rejection : [> 30dB]

Distortion at RF=50mV, m=80% : [< 5%]

AMPLIFIER:

Output power (6 Ω , 1kHz, 10% THD)
 L & R : 2 x 50W RMS /21M/22

Output power (6 Ω , 60Hz-12.5kHz, 10% THD)
 L & R : 2 x 40W FTC /37

Frequency response within -3dB : 50Hz-16kHz

Incredible Surround : ON/OFF

Treble : 12.5kHz \pm 3 Steps

Bass : 55Hz \pm 3 Steps

Woox : Level 1, 2, 3 & OFF

Input sensitivity

Aux in (at 1kHz) : 500mV \pm 3dB at 600 Ω
 CDR in (at 1kHz) : 1V \pm 3dB at 600 Ω

Output sensitivity

Line out (Left/Right) : 500mV \pm 3dB at 22k Ω
 Subwoofer out (50Hz - 8kHz) : 1.5V \pm 3dB at 22k Ω
 Headphone output at 32 Ω : 680mV \pm 1dB (Vol. Max.)

COMPACT DISC:

Measurement done directly at the connector on the board.

Output resistance : < 100 Ω

Output voltage (in Vrms) : 550mV \pm 1dB (unloaded)

Frequency deviation : < 1%

Channel unbalance : < \pm 1dB

Frequency response : < \pm 1.5dB for 20Hz-20kHz

Signal to Noise Ratio (A-weighted) : > 80dBA

Distortion at 1kHz : < 0.02%

Crosstalk (1kHz) : >60dB

[...] Values indicated are for "ECO6 Cenelec Board" only.

MEASUREMENT SETUP

Tuner FM

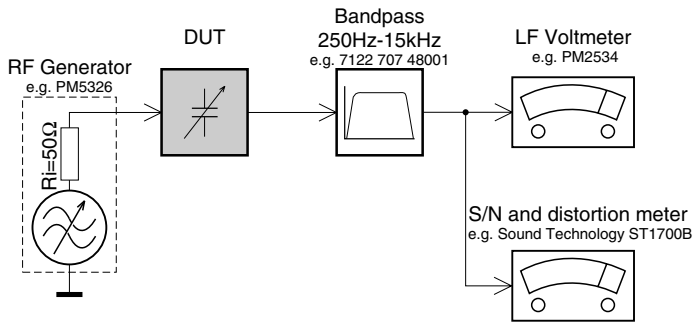

Use a bandpass filter to eliminate hum (50Hz, 100Hz) and disturbance from the pilotone (19kHz, 38kHz).

Tuner AM (MW,LW)

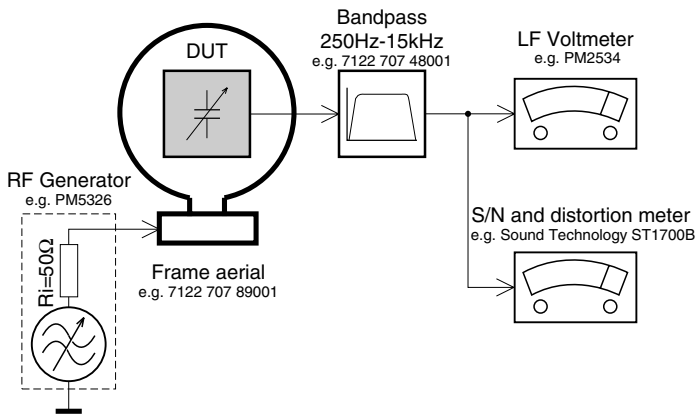

To avoid atmospheric interference all AM-measurements have to be carried out in a Faraday's cage.
Use a bandpass filter (or at least a high pass filter with 250Hz) to eliminate hum (50Hz, 100Hz).

CD

Use Audio Signal Disc SBC429 4822 397 30184
(replaces test disc 3)

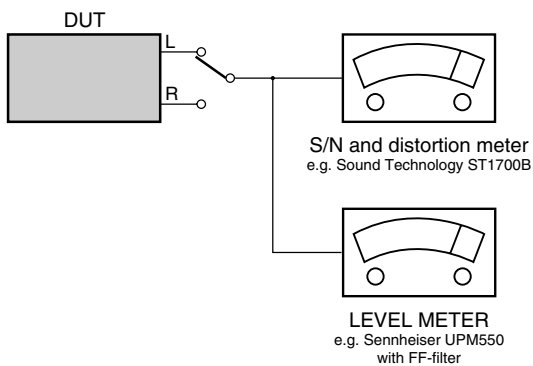

Recorder

Use Universal Test Cassette **CrO2** SBC419 4822 397 30069
or Universal Test Cassette **Fe** SBC420 4822 397 30071

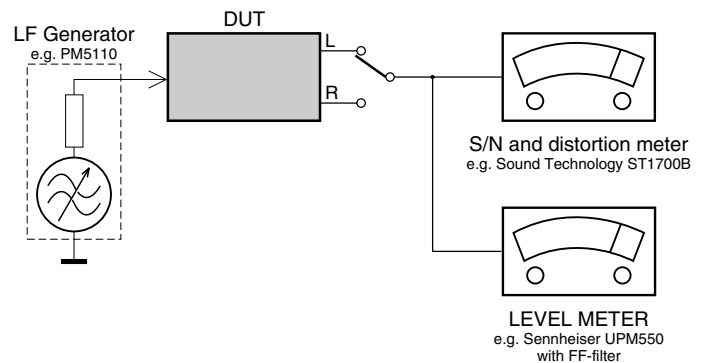

SERVICE AIDS

Service Tools:

Universal Torx driver holder	4822 395 91019
Torx bit T10 150mm	4822 395 50456
Torx driver set T6 - T20	4822 395 50145
Torx driver T10 extended	4822 395 50423

Cassette:

SBC419 Test cassette CrO2	4822 397 30069
SBC420 Test cassette Fe	4822 397 30071
MTT150 Dolby level 200nWb/M	4822 397 30271

Compact Disc:

SBC426/426A Test disc 5 + 5A	4822 397 30096
SBC442 Audio Burn-in Test disc 1kHz	4822 397 30155
SBC429 Audio Signals disc	4822 397 30184
Dolby Pro-logic Test Disc	4822 395 10216

ESD Equipment:

Anti-static table mat - large 1200x650x1.25mm ...	4822 466 10953
Anti-static table mat - small 600x650x1.25mm	4822 466 10958
Anti-static wristband	4822 395 10223
Connector box (1M Ω)	4822 320 11307
Extension cable (to connect wristband to conn. box)	4822 320 11305
Connecting cable (to connect table mat to conn. box)	4822 320 11306
Earth cable (to connect product to mat or box)	4822 320 11308
Complete kit ESD3 (combining all above products)	4822 320 10671
Wristband tester	4822 344 13999

HANDLING CHIP COMPONENTS

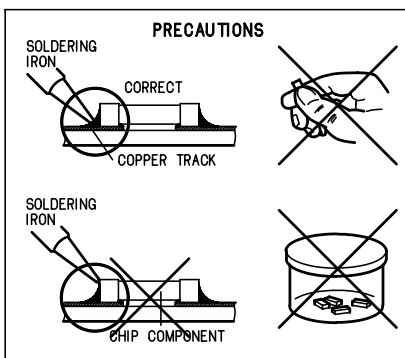
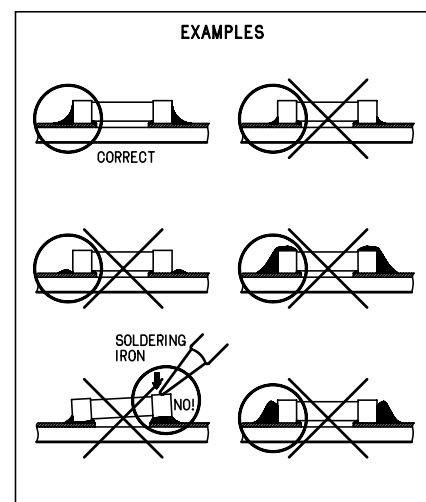
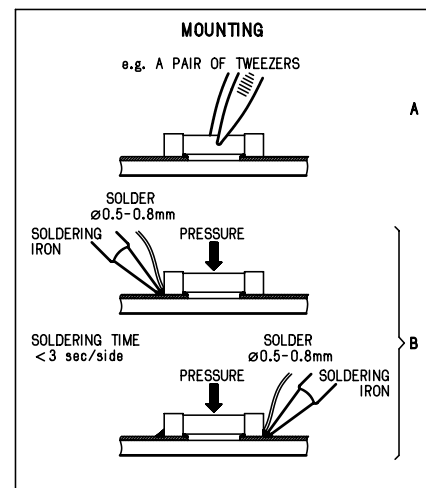
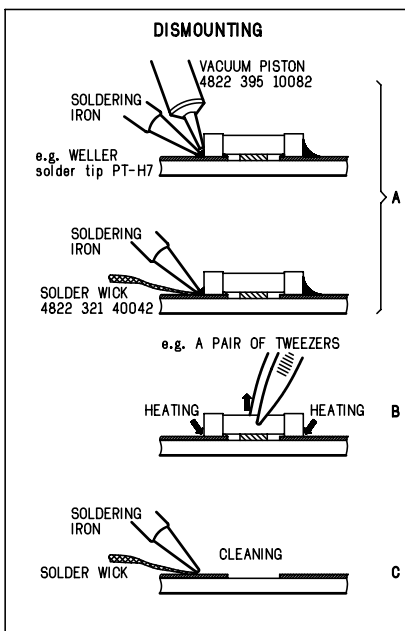
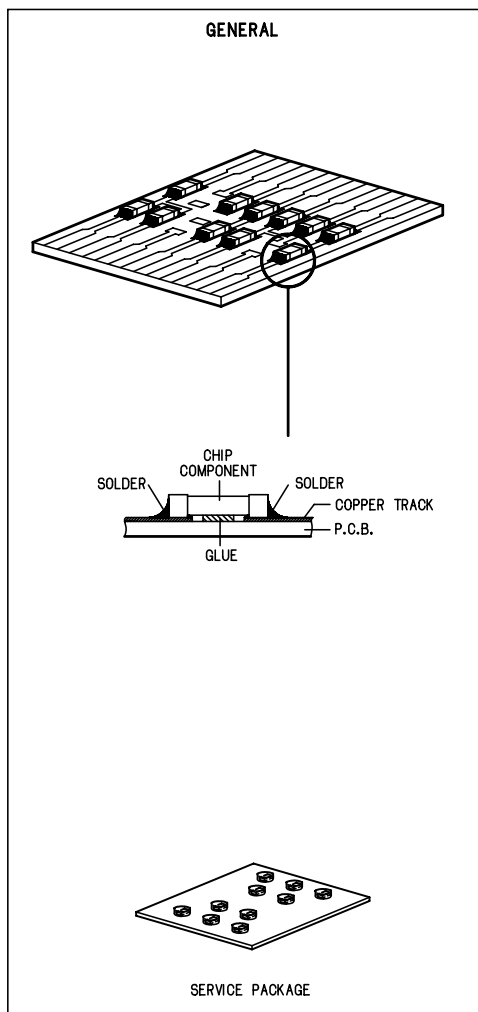

(GB) WARNING

All ICs and many other semi-conductors are susceptible to electrostatic discharges (ESD). Careless handling during repair can reduce life drastically.

When repairing, make sure that you are connected with the same potential as the mass of the set via a wrist wrap with resistance. Keep components and tools also at this potential.

(F) ATTENTION

Tous les IC et beaucoup d'autres semi-conducteurs sont sensibles aux décharges statiques (ESD).

Leur longévité pourrait être considérablement écourtée par le fait qu'aucune précaution n'est prise à leur manipulation.

Lors de réparations, s'assurer de bien être relié au même potentiel que la masse de l'appareil et enfiler le bracelet serti d'une résistance de sécurité.

Veiller à ce que les composants ainsi que les outils que l'on utilise soient également à ce potentiel.

(GB)

Safety regulations require that the set be restored to its original condition and that parts which are identical with those specified, be used.

(NL)

Veiligheidsbepalingen vereisen, dat het apparaat bij reparatie in zijn oorspronkelijke toestand wordt teruggebracht en dat onderdelen, identiek aan de gespecificeerde, worden toegepast.

(F)

Les normes de sécurité exigent que l'appareil soit remis à l'état d'origine et que soient utilisées les pièces de rechange identiques à celles spécifiées.

(D)

Bei jeder Reparatur sind die geltenden Sicherheitsvorschriften zu beachten. Der Originalzustand des Geräts darf nicht verändert werden; für Reparaturen sind Original-Ersatzteile zu verwenden.

(I)

Le norme di sicurezza esigono che l'apparecchio venga rimesso nelle condizioni originali e che siano utilizzati i pezzi di ricambio identici a quelli specificati.

"After servicing and before returning set to customer perform a leakage current measurement test from all exposed metal parts to earth ground to assure no shock hazard exist. The leakage current must not exceed 0.5mA."

ESD**(D) WARNUNG**

Alle ICs und viele andere Halbleiter sind empfindlich gegenüber elektrostatischen Entladungen (ESD).
Unvorsichtige Behandlung im Reparaturfall kann die Lebensdauer drastisch reduzieren.
Veranlassen Sie, dass Sie im Reparaturfall über ein Pulsarmband mit Widerstand verbunden sind mit dem gleichen Potential wie die Masse des Gerätes.
Bauteile und Hilfsmittel auch auf dieses gleiche Potential halten.

(NL) WAARSCHUWING

Alle IC's en vele andere halfgeleiders zijn gevoelig voor electrostatische ontladingen (ESD).
Onzorgvuldig behandelen tijdens reparatie kan de levensduur drastisch doen verminderen.
Zorg ervoor dat u tijdens reparatie via een polsband met weerstand verbonden bent met hetzelfde potentiaal als de massa van het apparaat.
Houd componenten en hulpmiddelen ook op ditzelfde potentiaal.

(I) AVVERTIMENTO

Tutti IC e parecchi semi-conduttori sono sensibili alle scariche statiche (ESD).
La loro longevità potrebbe essere fortemente ridotta in caso di non osservazione della più grande cauzione alla loro manipolazione.
Durante le riparazioni occorre quindi essere collegato allo stesso potenziale che quello della massa dell'apparecchio tramite un braccialetto a resistenza.
Assicurarsi che i componenti e anche gli utensili con quali si lavora siano anche a questo potenziale.

"Pour votre sécurité, ces documents doivent être utilisés par des spécialistes agréés, seuls habilités à réparer votre appareil en panne".

**(GB) Warning !**

Invisible laser radiation when open.
Avoid direct exposure to beam.

(S) Varning !

Osynlig laserstrålning när apparaten är öppnad och spärren är urkopplad. Betrakta ej strålen.

(SF) Varoitus !

Avatussa laitteessa ja suojaletyksen ohitettaessa olet alltiina näkymättömälle laserisäteilylle. Älä katso säteeseen!

(DK) Advarse !

Usynlig laserstråling ved åbning når sikkerhedsafbrydere er ude af funktion. Undgå udsættelse for stråling.

DISMANTLING INSTRUCTIONS

Opening of the Universal Loader Tray manually & Dismantling of the Cover Tray

- 1) Loosen 6 screws and remove the Cover Top (pos 255) by sliding it out towards the rear before lifting up.
 - 4 screws on the rear
 - 1 screw each on the left & right side
- 2) Loosen 2 screws each to remove the Panel Left (pos 253) and Panel Right (pos 254). The Panels are removed by sliding it towards the rear and outwards.
 - 1 screw on the side
 - 1 screw on the rear
- 3) Take a paper clip or any stiff wire diameter of 1mm-1.5mm and make a marking about 40mm from the tip as shown in Figure 1.
- 4) Place the set in the position as shown in Figure 2 and insert the paper clip or stiff wire into the hole on the Left side of the Cabinet Front (pos 101).

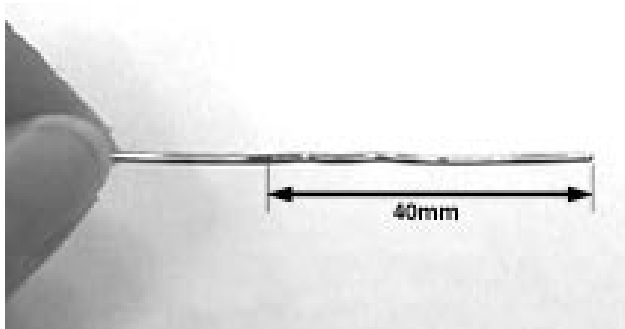

Figure 1

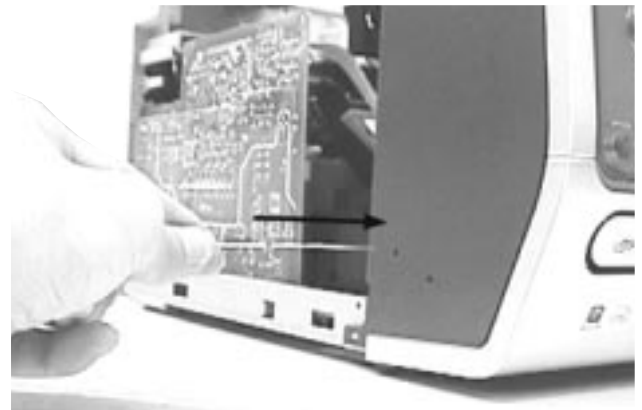

Figure 2

- 5) With the marking just outside the hole on the Cabinet Front (pos 101) as shown in Figure 3, you have to feel and give a push to unlock the tray of the Universal Loader before sliding it out.
- 6) With the tray of the Universal Loader opened, remove the Cover Tray (pos 158) as shown in Figure 4.



Figure 3



Figure 4

DISMANTLING INSTRUCTIONS

Detaching the Front Panel assembly from the Bottom/Rear assembly

- 1) Remove 2 screws A (pos 226) as shown in Figure 5 from the bottom of the Cabinet Front (pos 101).
- 2) Release the fixation of the Combi Board (pos 1101-1001) to Bracket Combi (pos 252) by releasing the 2 catches C2 (see Figure 6) and pulling the board outwards as shown in Figure 7.
- 3) Uncatch 2 catches C1 (see Figure 6) on the left & right sides of the Cabinet Front (pos 101) and slides the Front Panel assembly out towards the front.
- 4) Remove 2 screws B (pos 225) as shown in Figure 8 to remove the Universal Loader (pos 1109).

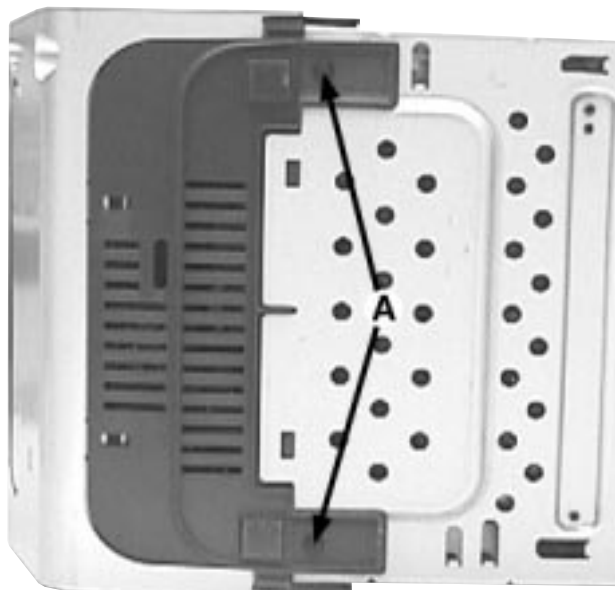

Figure 5

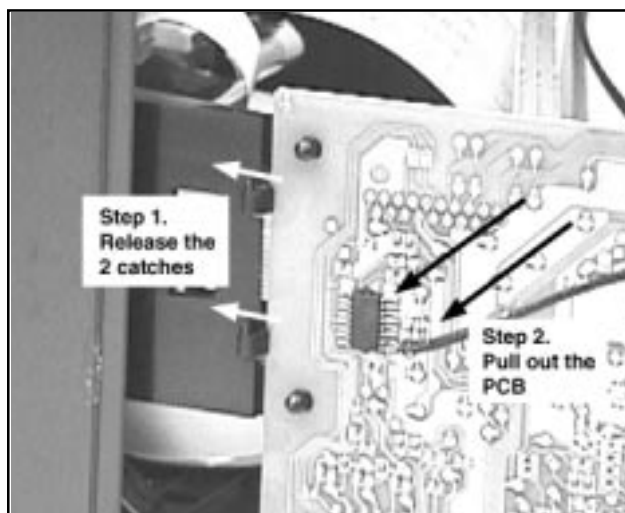

Figure 7

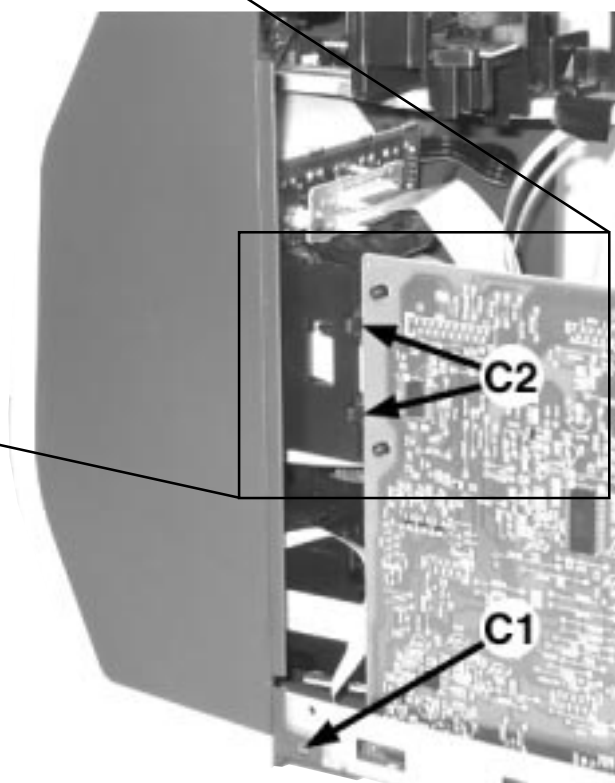

Figure 6

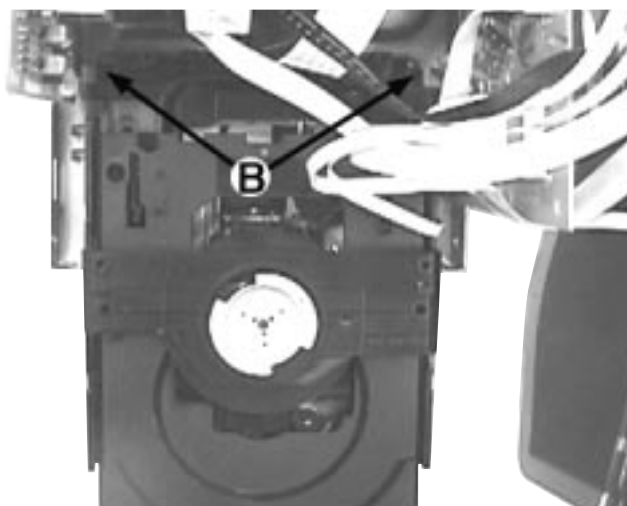

Figure 8

DISMANTLING INSTRUCTIONS

Dismantling of the Front Panel assembly

- 1) Loosen 3 screws D (see Figure 9) to remove the Control Board (pos 1107-B).
- 2) Loosen 2 screws E (see Figure 9) to remove the ECO Standby Board (pos 1107-D).
- 3) Loosen 4 screws F (see Figure 9) to remove the Volume Board (pos 1107-H).
- 4) Loosen 2 screws G (see Figure 9) to remove the Bracket Combi (pos 252).
- 5) Loosen 2 screws H (see Figure 10) to remove the Headphone Board (pos 1107-F).
- 6) Loosen 6 screws J (see Figure 11) to remove the Display Board (pos 1107-A).
- 7) Loosen 4 screws K (see Figure 12) to remove the Shuttle Board (pos 1107-G).
- 8) Loosen 2 screws L (see Figure 12) to remove the LCD Interconnect Board (pos 1107-J).

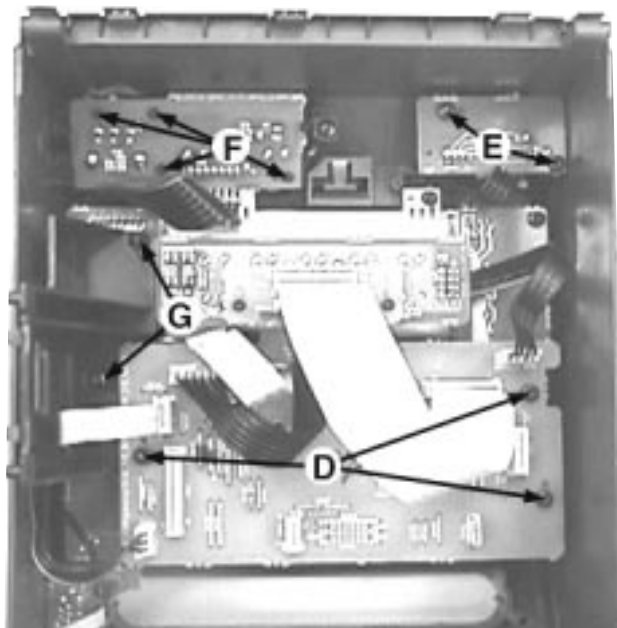

Figure 9

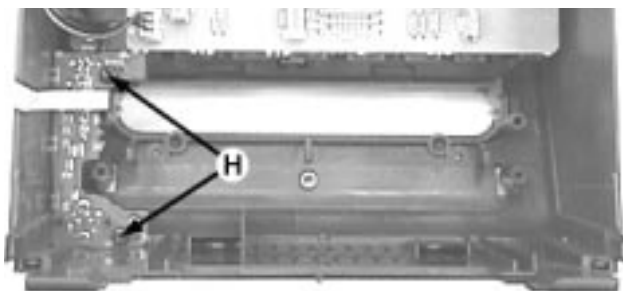

Figure 10

- 9) Loosen 1 screws V (see Figure 12) to remove the Infra Receiver Board (pos 1107-E).
- 10) Loosen 2 screws M (see Figure 13) to remove the LCD Back Light Board (pos 1107-C).

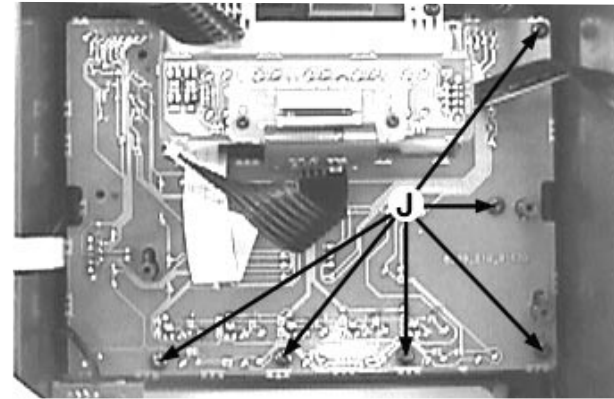

Figure 11

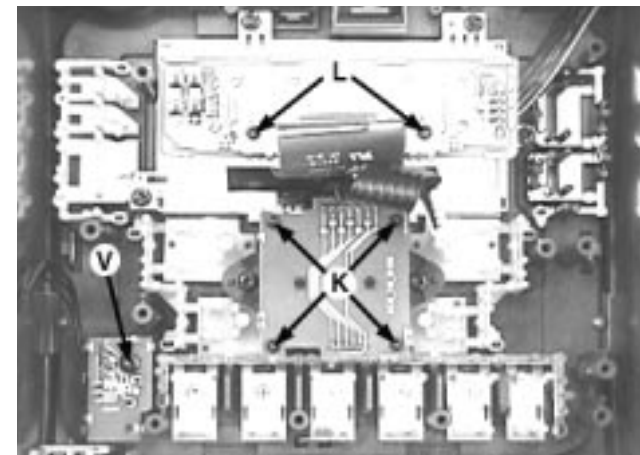

Figure 12

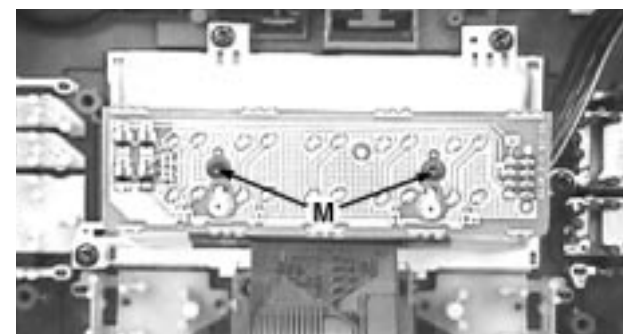
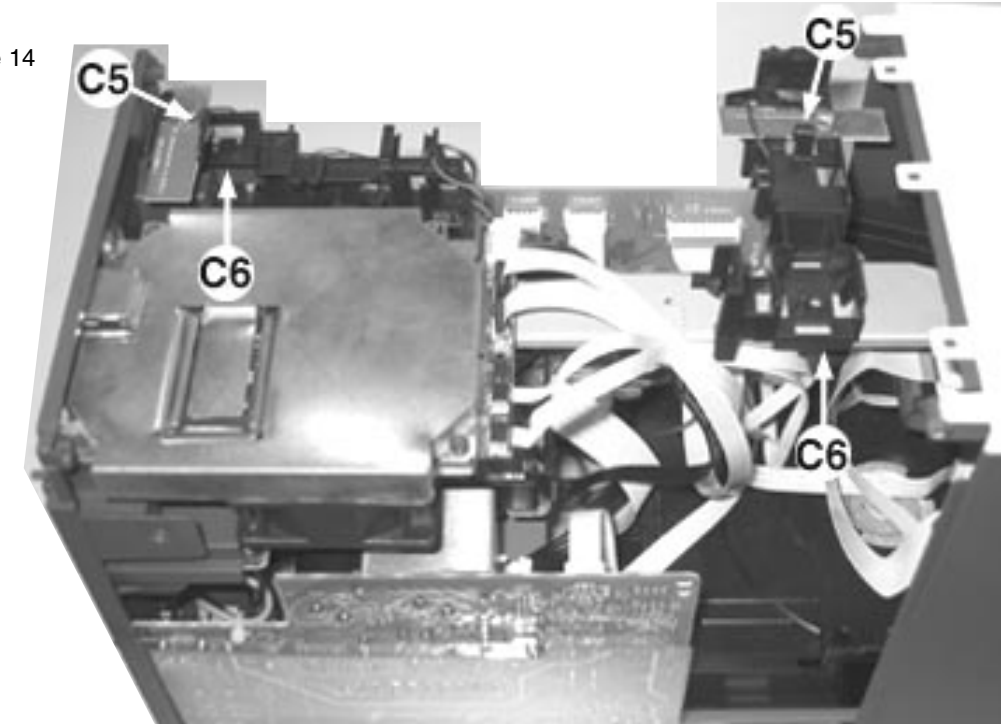

Figure 13

Dismantling of the Antenna Board, Bracket Antenna and Internet Audio Module

- 1) Uncatch the catches C5 (see Figure 14) to remove the Antenna Board (pos 1106).
- 2) Uncatch the catches C6 (see Figure 14) and push upward to remove the Bracket Antenna (pos 250).

Figure 14



- 3) Loosen 2 screws N (see Figure 14A) to remove the Internet Audio Module assembly.
- 4) Loosen 4 screws P (see Figure 14B) to open the Shield IAM (pos 262).
- 5) Loosen 2 screws P1 (see Figure 14C) to remove the Fan (pos 1111).

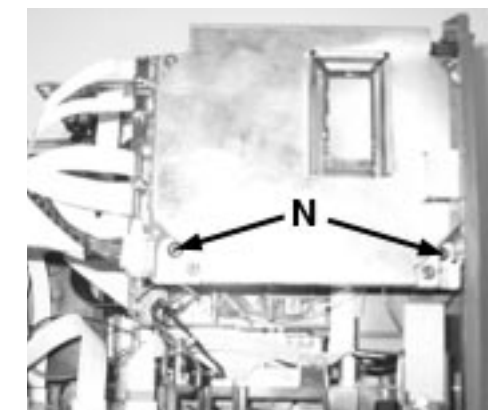

Figure 14A

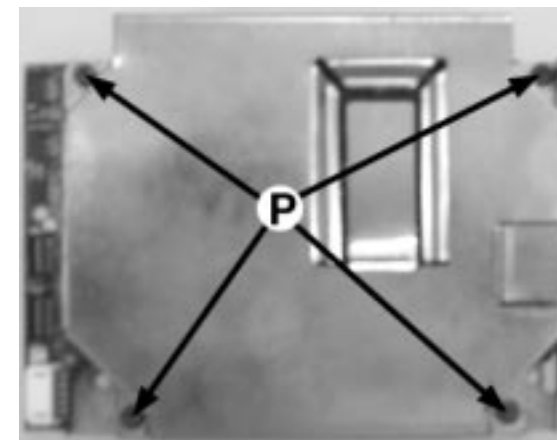

Figure 14B

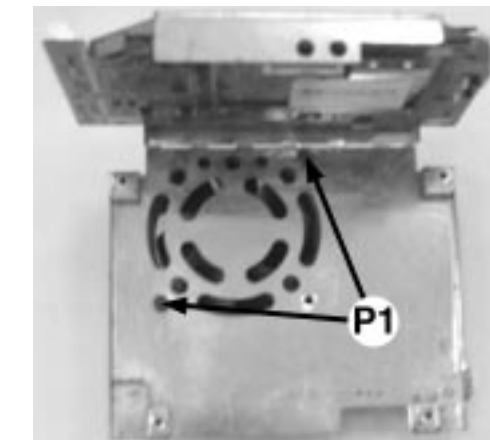

Figure 14C

DISMANTLING INSTRUCTIONS

Dismantling of the Rear Panel

- 1) Loosen 3 screws Q and 2 catches C3 (see Figure 15) to remove the Tuner Board assembly.
- 2) Loosen 1 screw S (see Figure 15) to free the Mains Socket Board from the Panel Rear (pos 256).
- 3) Loosen 5 screws R and 2 catches C4 (see Figure 15) to remove the Panel Rear (pos 256) by sliding it out towards the rear.

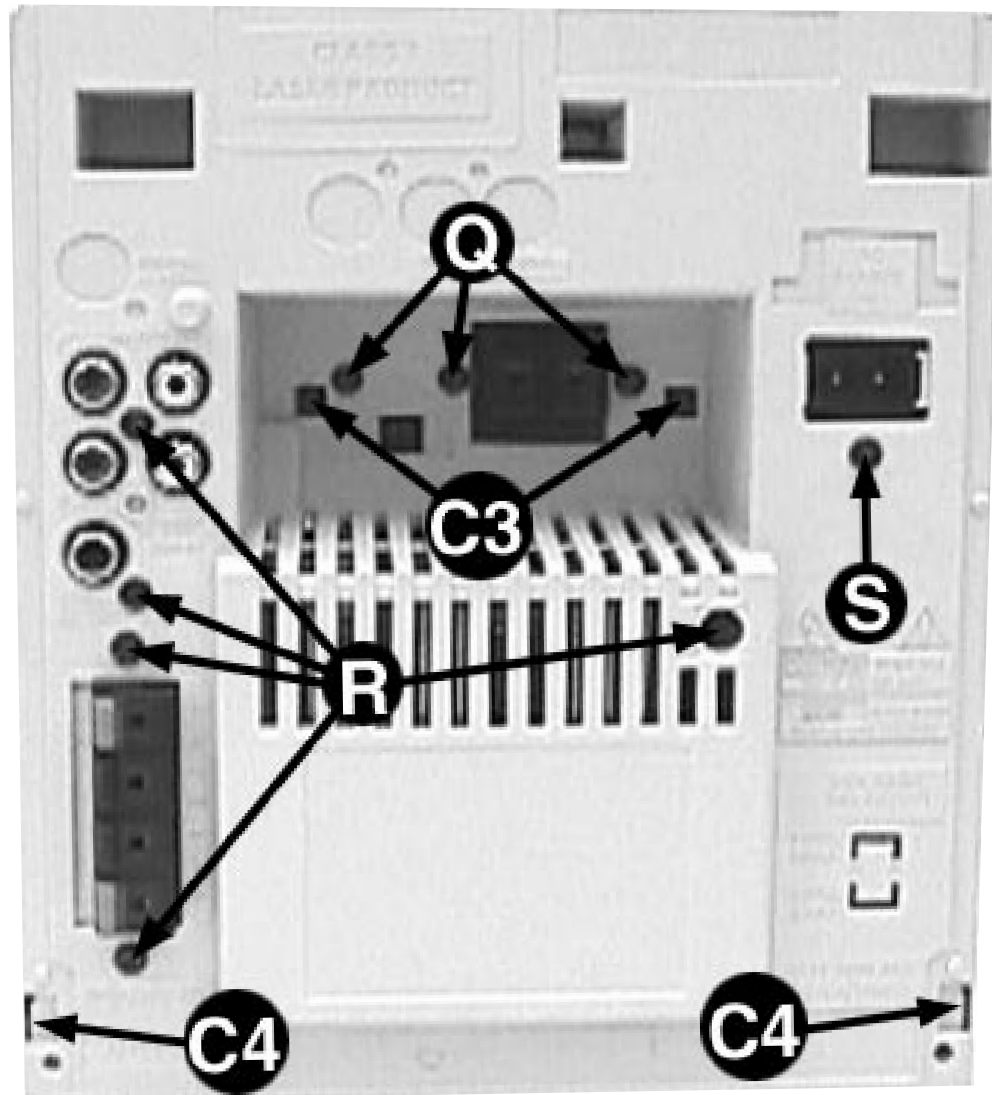

Figure 15

Dismantling of the Bottom assembly

- 1) Loosen 2 screws T as shown in Figure 16 to remove the Combi & Regulator boards assembly (pos 1101-1001 & pos 1101-1003).
- 2) Loosen 2 screws U as shown in Figure 17 to remove the Housing Fan Top (pos 267).
Note : During Fan (pos 1110) replacement, care should be taken to ensure that the following are correct:
 - fan blade direction
 - fan wire position

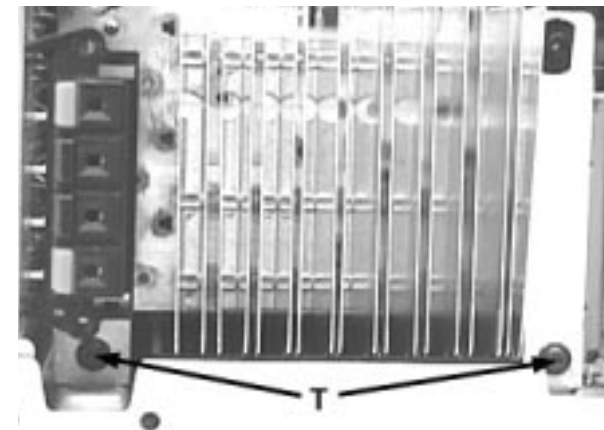

Figure 16

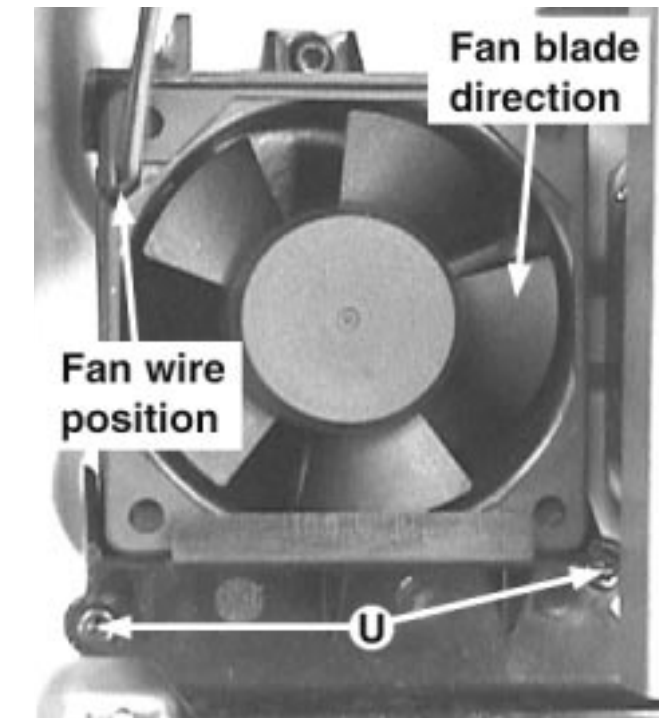

Figure 17

Repair Hints

- 1) During repair it is possible to disconnect the ECO6 Tuner Board completely unless the fault is suspected to be in that area. This will not affect the performance of the rest of the set.
- 2) Care should be taken not to damage or tear the LCD Module Cable during repair (see Figure 18 & Figure 19). The LCD Module Cable may be damage or tear as shown in Figure 20 if too much force is applied when removing the Black Tape during repair.

Note: The flex cables are very fragile, care should be taken not to damage them during repair. After repair, be very sure that the flex cables are inserted properly into the flex sockets before encasing, otherwise faults may occurs.

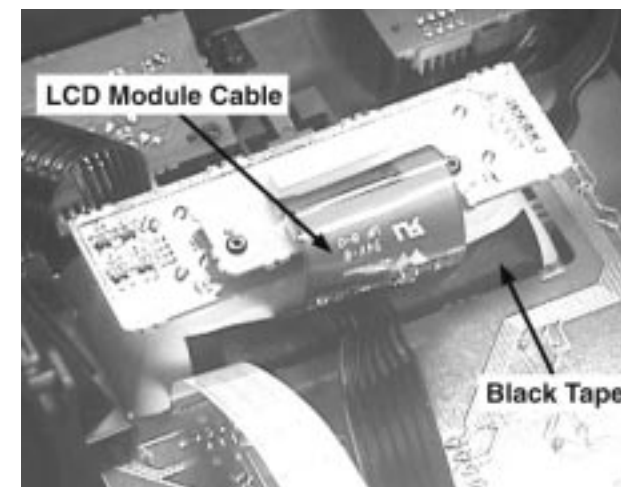

Figure 18

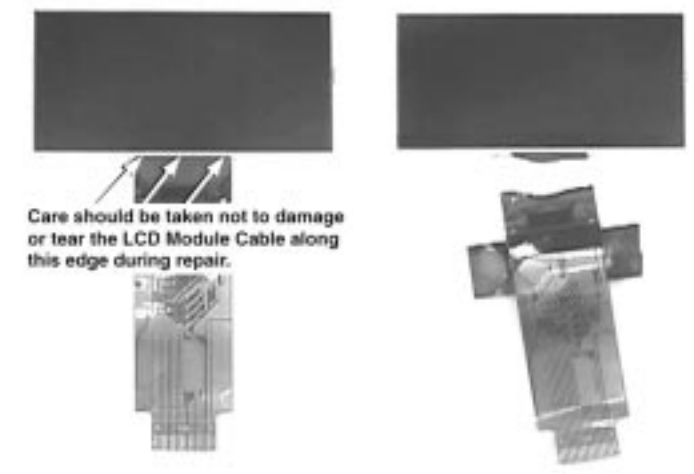
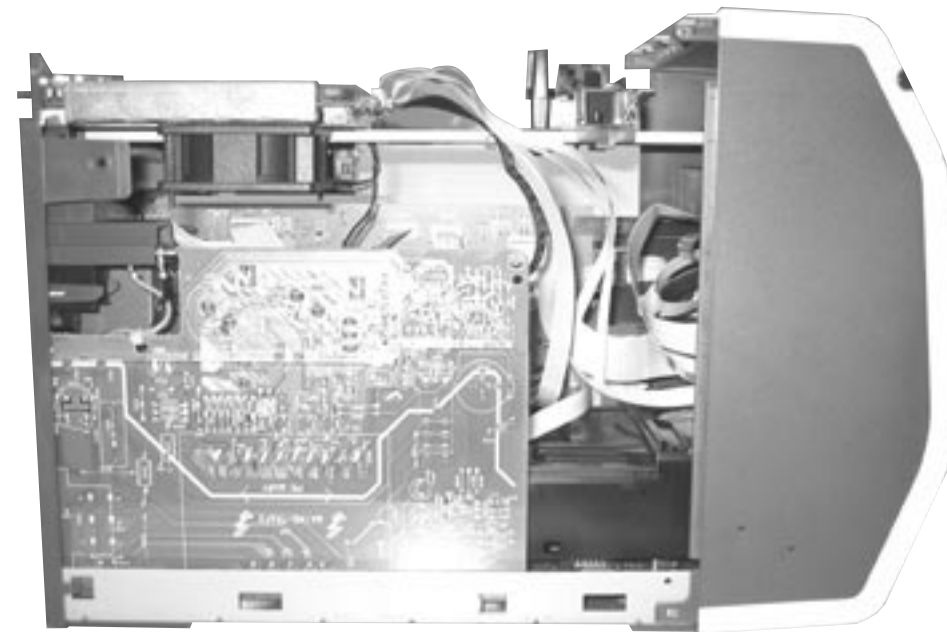
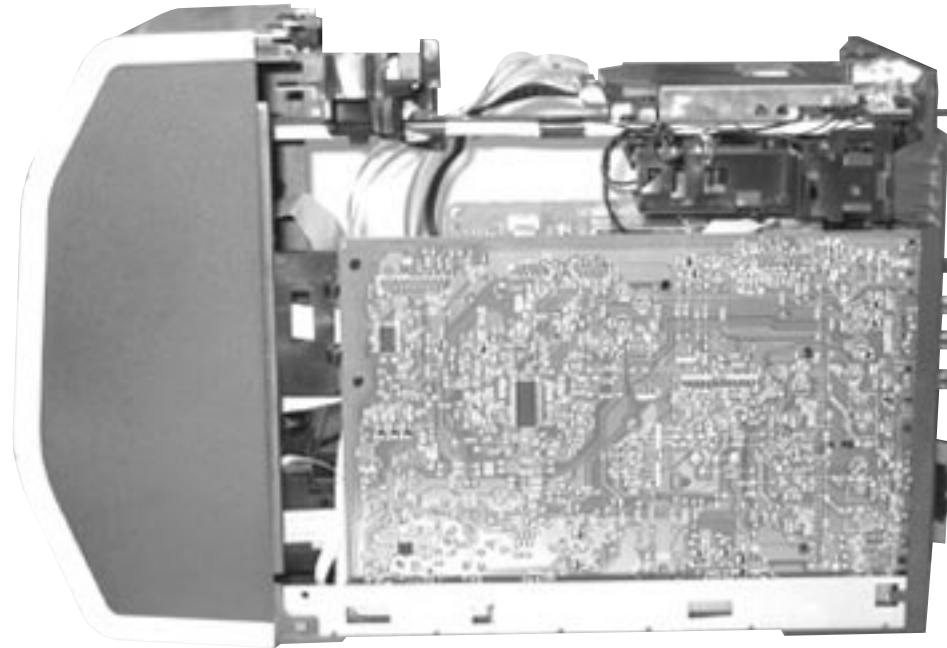

Figure 19

Figure 20

DISMANTLING INSTRUCTIONS

Service position A



Service position B

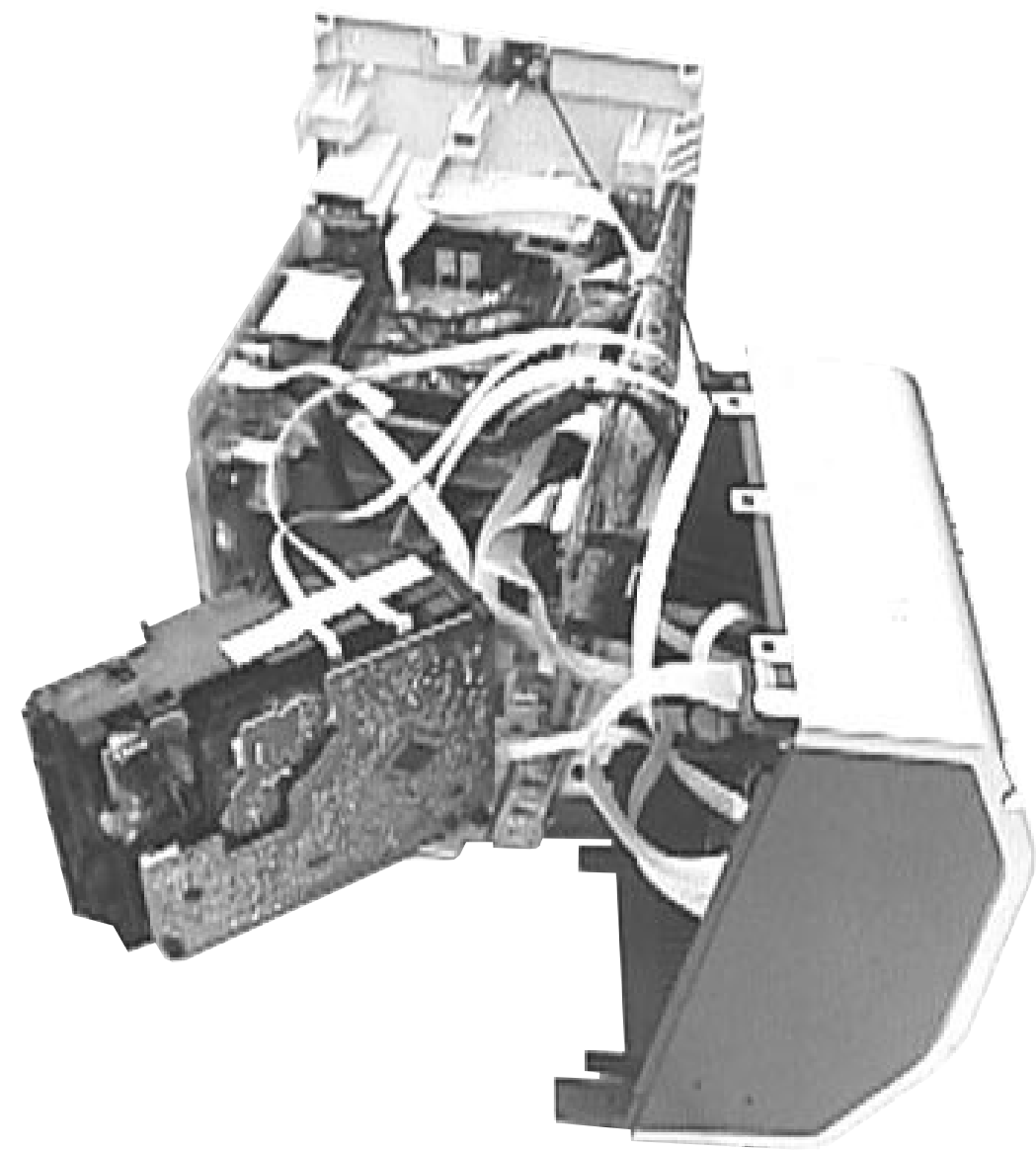

SERVICE TEST PROGRAM

S refers to Service Mode
 V refers to Version
 yy refers to Software version number of the uProcessor (counting up from 01 to 99)

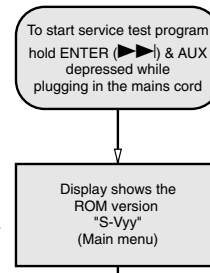

Module Internet Audio - Software Upgrading

Press INTERNET button followed by OPTIONS button, then press the Right-Hand Soft Key (◀) on the set to select the "SET OPTIONS".
 Use the navigation Jog Shuttle to select "ONLINE UPGRADE" from the list and press OK (▶) to confirm and follow the instruction given on the display.

Module Internet Audio - Clear Email Address and Presets memory

By holding the INTERNET and ENTER (▶▶) buttons depressed while switching on the Mains supply (without the need to be in either Service or Factory mode), all Email address and presets stored in the memory will be cleared.

The display will show "STARTING UP" for a few seconds. When the stored information in the memory has been cleared, the display will show "FACTORY RESET". Subsequently, the software is upgraded (if necessary) when the set is first connected to the internet.

Alternatively, press INTERNET button followed by OPTIONS button, then press the Right-Hand Soft Key (◀) on the set to select the "SET OPTIONS".
 Use the navigation Jog Shuttle to select "RESET SETTINGS" from the list and press OK (▶) to confirm and follow the instruction given on the display.

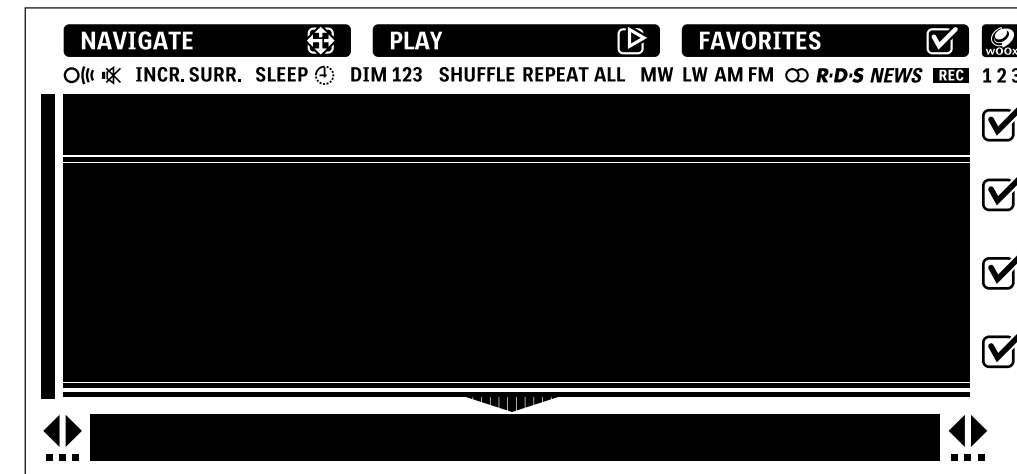
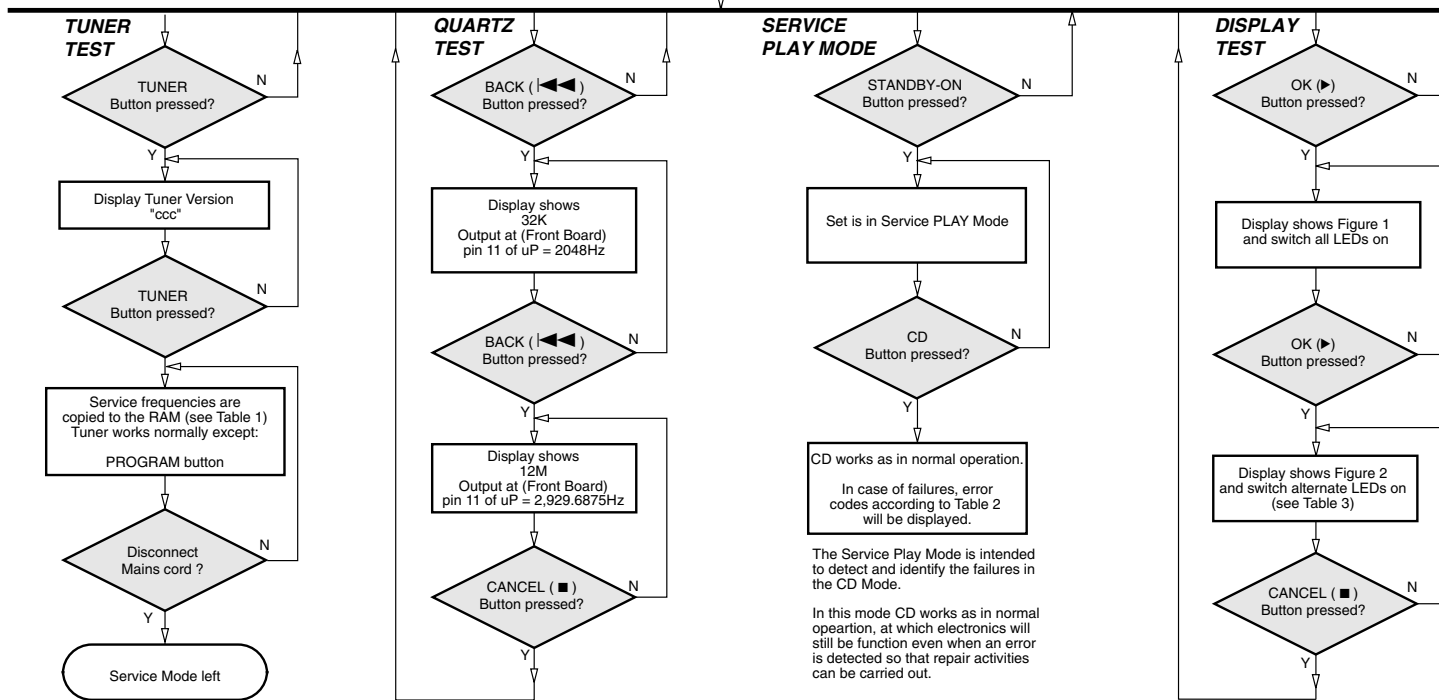

Figure 1

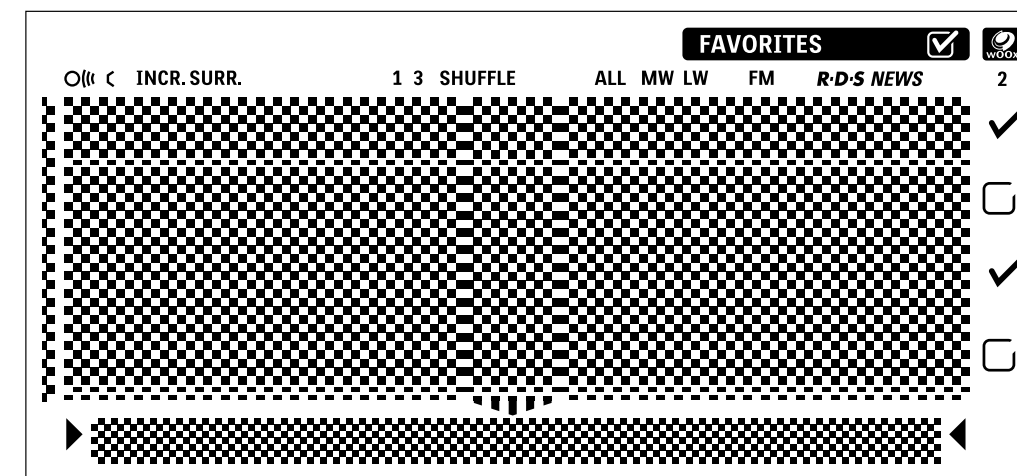

Figure 2

PRESET	Europe "EUR"	USA "USA"	Oversea "OSE"
1	87.5MHz	87.5MHz	87.5MHz
2	108MHz	108MHz	108MHz
3	531kHz	530kHz	531/530kHz*
4	1602kHz	1700kHz	1602/1700kHz*
5	558kHz	560kHz	558/560kHz*
6	1494kHz	1500kHz	1494/1500kHz*
7	153kHz	98MHz	87.5/98MHz*
8	279kHz	87.5MHz	87.5MHz
9	198kHz	87.5MHz	87.5MHz
10	98MHz	87.5MHz	87.5MHz
11	87.5MHz	87.5MHz	98/87.5MHz*

Table 1

* Depending on the selected grid frequency (9 or 10kHz).

Note: By holding the TUNER and ENTER (▶▶) buttons depressed while switching on the Mains supply, the tuning grid frequency is toggled between 9kHz and 10kHz for the Oversea (21) version.

Service Play Mode Error Codes

Error code	Error Description
E1000	Focus Error Triggered when the focus cannot be found within a certain time when starting up the CD, or if the focus is lost for more than a certain time during playing of CD.
E1001	Radial Error Triggered when the radial servo is off-track for a certain time during playing the CD.
E1002	Sledge In Error The sledge did not reach its inner position (inner-switch is close) before approximately 6 sec. have passed by - Inner-switch or sledge motor problem.
E1003	Sledge Out Error The sledge did not come out of its inner position (inner-switch is open) before approximately 250ms have passed by - Inner-switch or sledge motor problem.
E1005	Jump Error Triggered in normal play when the jump destination could not be found within a certain time.
E1006	Subcode Error Triggered when a new subcode was missing for a certain time during playing CD.
E1007	PLL Error The Phase-Lock-Loop could not lock within a certain time.
E1008	Turntable Motor Error Generated when the CD could not reached 75% of speed during startup within a certain time. Disc motor problem.
E1020	Focus Search Error The focus point has not been found within a certain time.
E1030	EBU Connection Error Generated when IM module could not receive any data from EBU interface within a certain time.
E1079	The drawer could not enter the inside position and is opening again. This can happen if the drawer is blocked such that it cannot go fully inside, or if the drawer switch is defective and does not close.

Table 2

LEDs	MC-i250
ECO POWER	On
PC LINK	On
TUNER	On
wOOx	On
LCD Back Light 2	On

Table 3

TEST	Activated with	ACTION
EEPROM TEST	ENTER (▶▶) CANCEL (■) to Exit	A test pattern will be sent to the EEPROM. "PASS" is displayed if the uProcessor read back the test pattern correctly, otherwise "FAIL" will be displayed.
EEPROM FORMAT TEST	OPTIONS	Load default data. Display shows "NEW" for 1 second. Caution! All presets from the customer will be lost!!
ROTARY ENCODER TEST	Rotary Volume Knob Jog Shuttle	Display shows value for 2 seconds. Values increases or decreases until Min. (-87dB) or Max. (0dB) is reached. Display shows "LEVEL -1" or "LEVEL +1" when the Jog Shuttle turn in anti-clockwise or clockwise for the first step. Display shows "LEVEL -2" or "LEVEL +2" when the Jog Shuttle turn in anti-clockwise or clockwise for the second step.
DEMO TOGGLE	TREBLE	Pressing this button will toggle between DEMO ON and DEMO OFF. The DEMO status will be displayed.
LEAVE SERVICE TEST PROGRAM	Disconnect mains cord	

SET BLOCK DIAGRAM

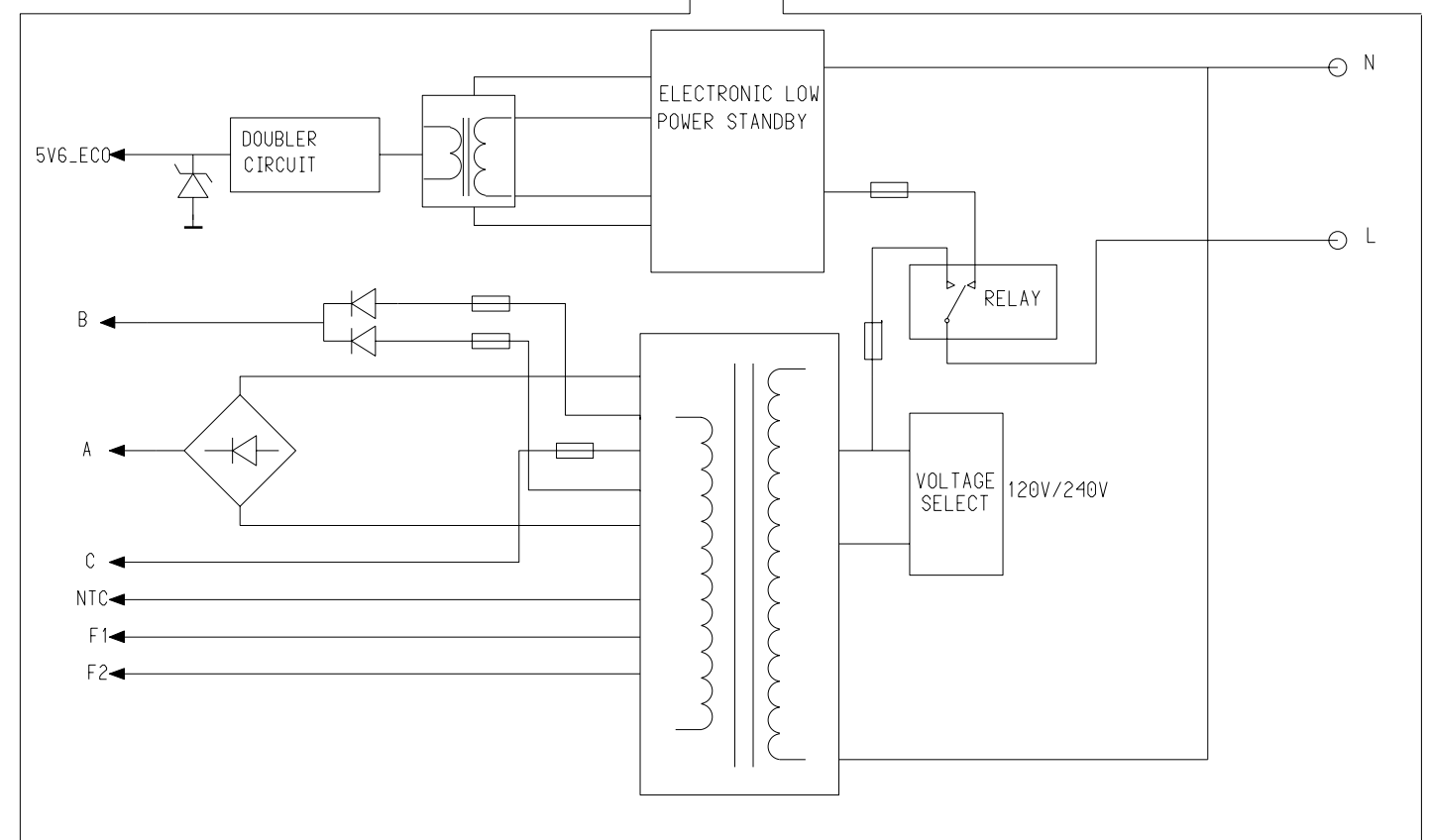
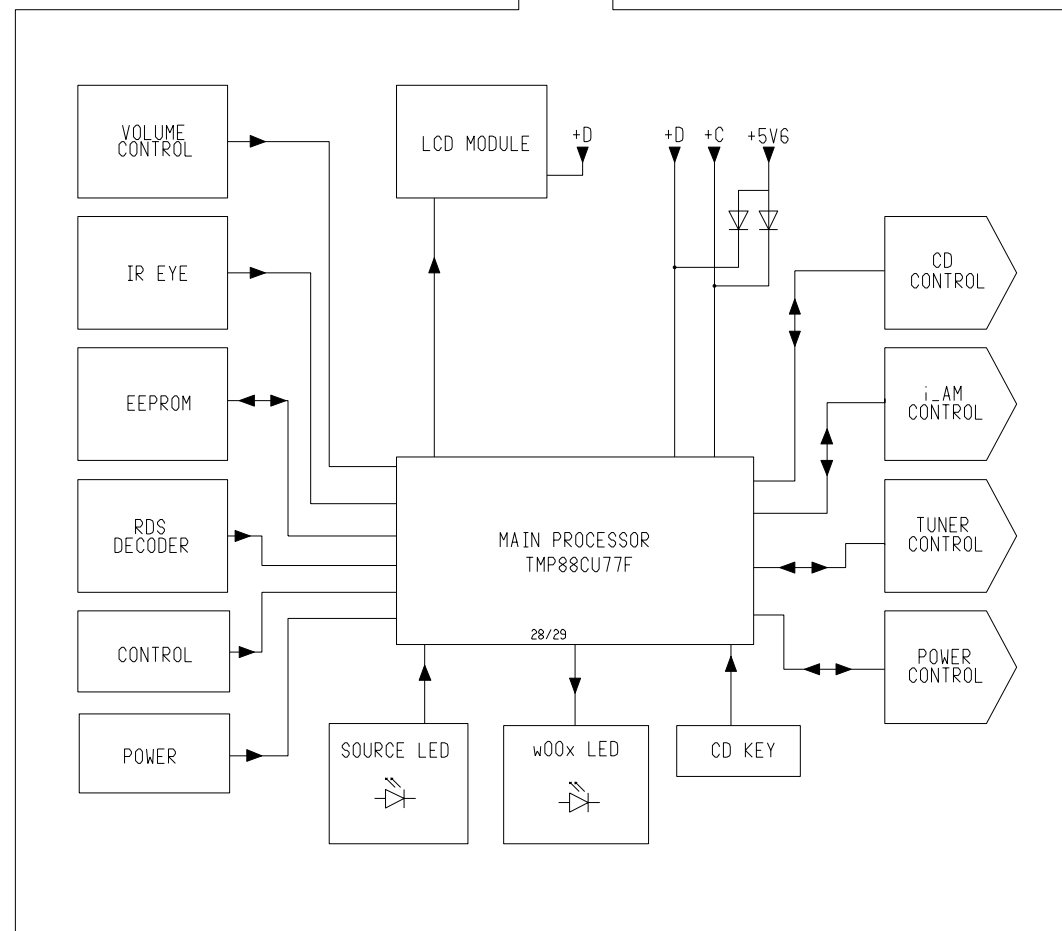
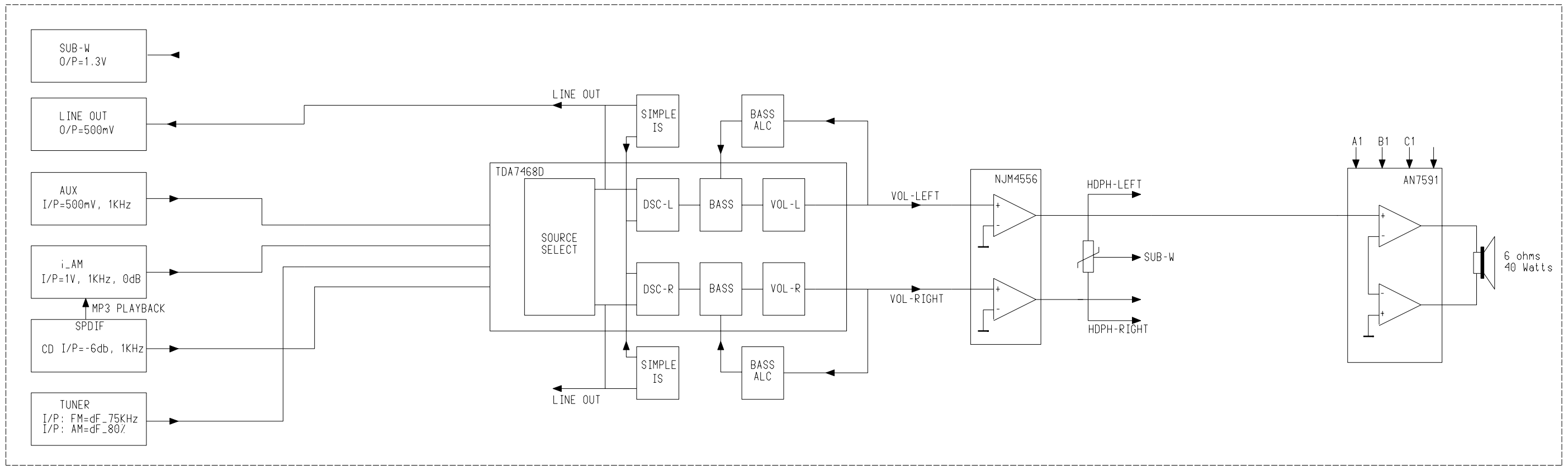

SET WIRING DIAGRAM

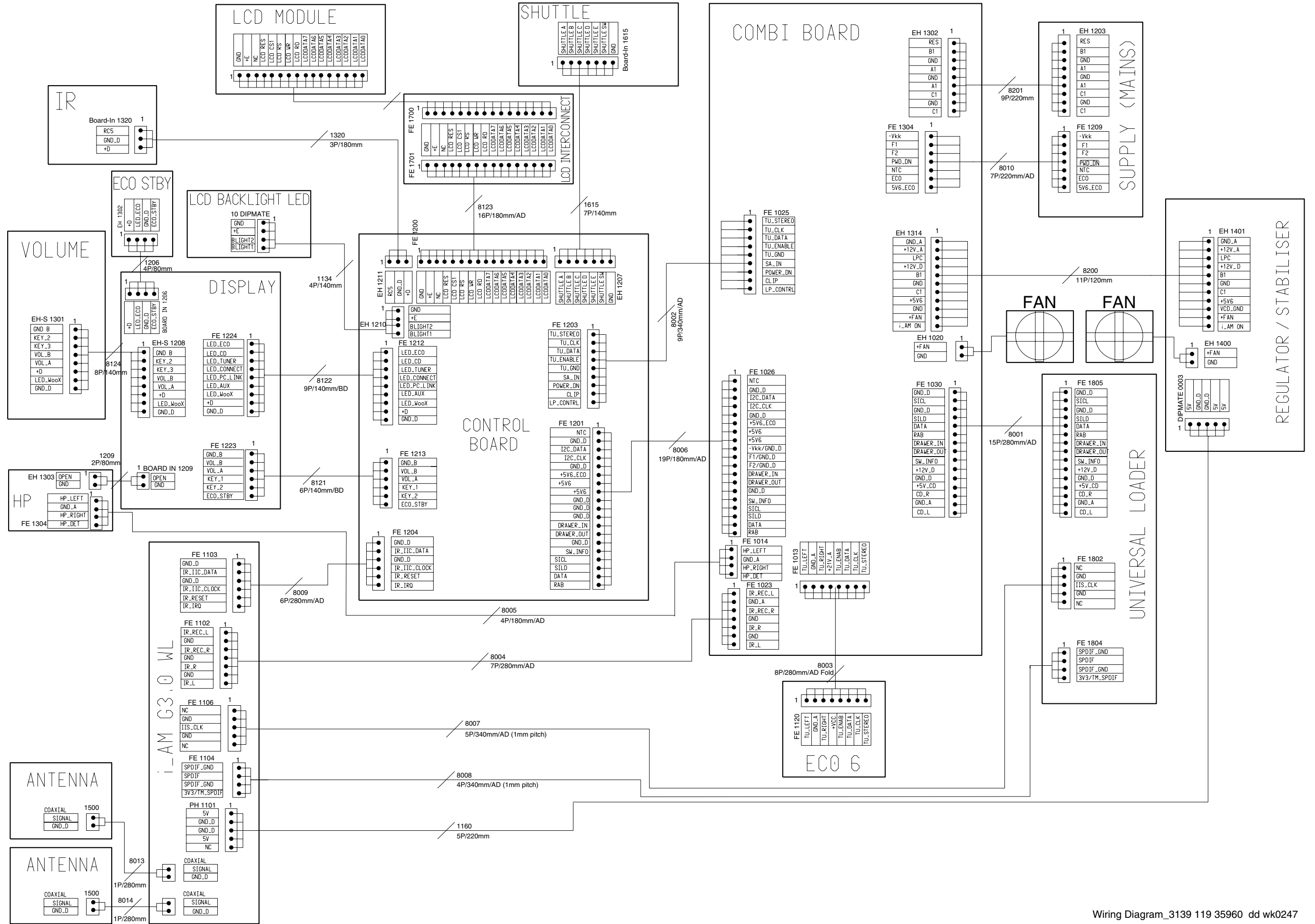

FRONT BOARD

TABLE OF CONTENTS

LCD Module - Block diagram 6-1
 LCD Module - Interface Pin Function 6-1
 Control Part - Component & Chip layout 6-2
 Control Part - Circuit diagram 6-3
 Display Part - Component & Chip layout 6-4
 Display Part - Circuit diagram 6-5
 ECO Standby Part - Layout & Circuit diagram 6-6
 Infra Receiver Part - Layout & Circuit diagram 6-6
 Headphone Part - Layout & Circuit diagram 6-7
 Shuttle Part - Layout & Circuit diagram 6-7
 LCD Interconnect Part - Layout & Circuit diagram 6-8
 LCD Back Light Part - Layout & Circuit diagram 6-9
 Volume Part - Layout & Circuit diagram 6-10
 Electrical parts list 6-11

LCD MODULE (WD-G1306K-7BNN)

BLOCK DIAGRAM

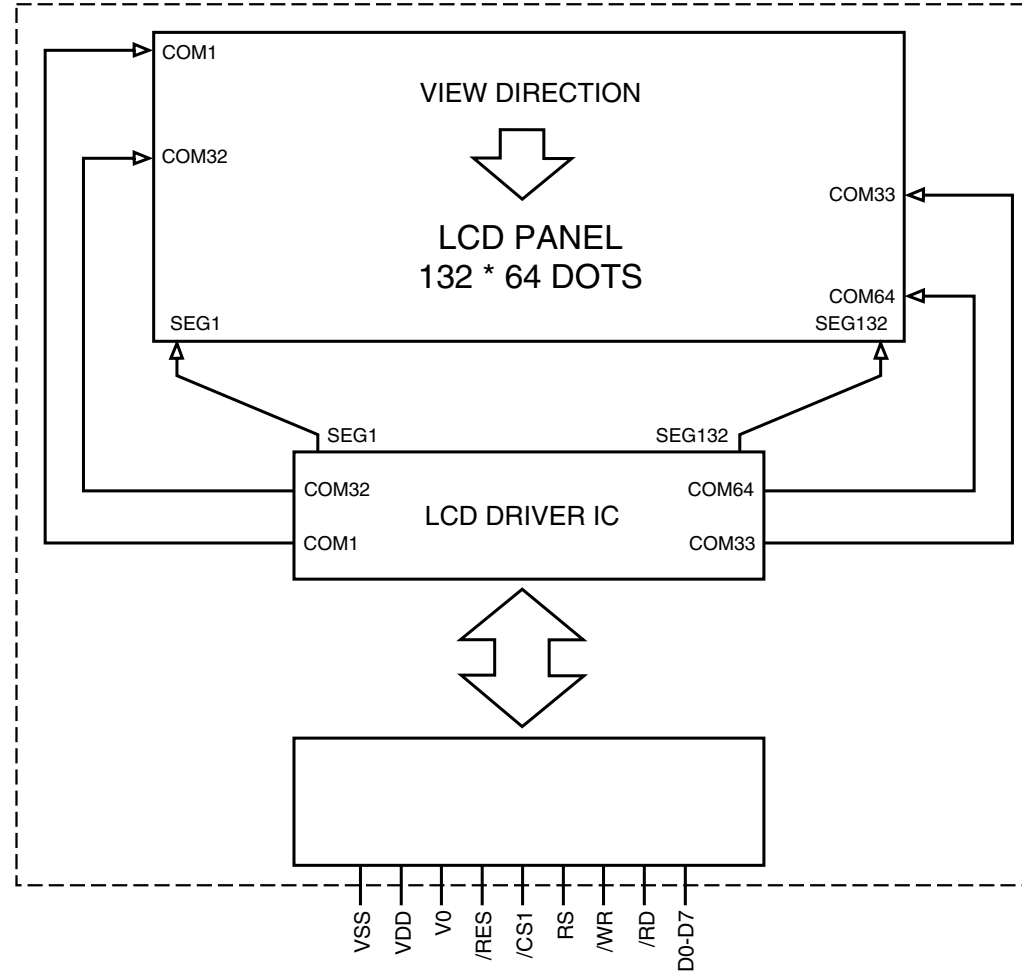

INTERFACE PIN FUNCTION

NO	SYMBOL	LEVEL	FUNCTION
1.	VSS	-	GND
2.	VDD	-	Power for Logic Circuit
3.	V0	-	V _{LCD} Output
4.	/RES	-	Reset
5.	/CS1	H/L	Chip Select
6.	RS	H/L	Instruction & Data Register Select H : D0 to D7 Display Data L : D0 to D7 are Display Control Data
7.	/WR	H/L	L : Writes Data to Internal Register
8.	/RD	H/L	L : Read Data from Register
9.	D7	H/L	Data Bus
10.	D6	H/L	Data Bus
11.	D5	H/L	Data Bus
12.	D4	H/L	Data Bus
13.	D3	H/L	Data Bus
14.	D2	H/L	Data Bus
15.	D1	H/L	Data Bus
16.	D0	H/L	Data Bus

CONTROL BOARD - COMPONENT LAYOUT

1200 A4	1207 A1	2101 B5	2430 A1	5448 C1	9421 C1	9426 B1	9431 C2	9436 A2	9441 C3	9446 B4
1201 C1	1210 A5	2401 B2	3401 C2	6400 A3	9422 A1	9427 B1	9432 B1	9437 C3	9442 C3	9447 B4
1202 A5	1211 C1	2403 B2	5400 B3	6415 B1	9423 B1	9428 B1	9433 B2	9438 C3	9443 C4	9448 B4
1203 B5	1212 A2	2405 A3	5401 C3	6416 B1	9424 A1	9429 C1	9434 A2	9439 C3	9444 C4	9449 C4
1204 C2	1213 B1	2407 B4	5402 C4	9420 C1	9425 A1	9430 C1	9435 A2	9440 C2	9445 B4	

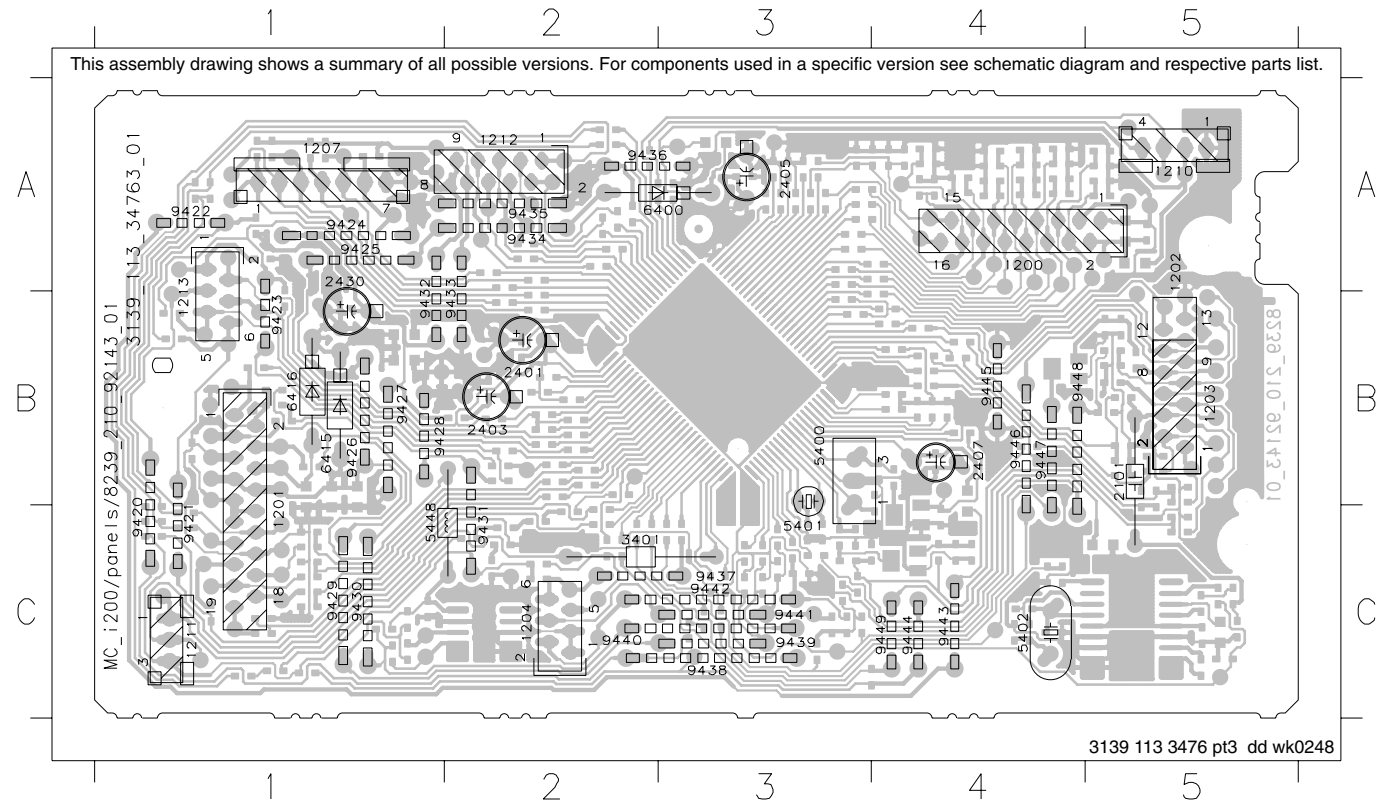

CONTROL BOARD - CHIP LAYOUT

2100 C1	2412 C3	2574 A2	3110 B2	3357 B1	3418 B4	3439 A3	3460 B3	3492 C5	3580 A5	3919 C5	4452 C3
2102 C2	2413 C3	2575 A2	3111 B2	3358 B5	3419 B4	3440 A3	3461 B2	3493 C5	3581 A5	3920 A5	4453 C3
2103 C2	2414 C3	2576 A2	3112 B2	3359 B5	3420 B4	3441 A3	3462 B3	3494 C5	3582 A5	3921 A5	4453 B2
2104 C1	2423 C3	2577 A2	3113 B2	3360 B5	3421 B4	3442 A3	3463 B2	3495 C3	3584 A5	4401 B5	5444 A1
2105 C1	2424 C2	2578 A2	3114 B1	3400 C3	3422 B4	3443 A3	3464 B2	3496 C3	3900 B4	4403 A5	5445 B5
2106 C1	2425 C2	2800 A1	3115 B1	3402 C3	3423 B4	3444 A3	3465 B2	3497 B4	3901 B4	4404 A5	5446 B5
2107 B1	2428 C5	2801 A1	3116 C2	3403 C3	3424 B4	3445 A3	3466 B2	3498 C3	3902 B4	4407 B2	5450 C1
2108 B1	2431 B1	2900 C5	3117 B1	3404 C3	3425 A4	3446 A3	3467 B2	3499 B4	3903 B4	4408 B4	5451 A3
2109 C1	2432 B5	2901 C5	3118 B1	3405 C4	3426 A4	3447 A3	3468 B2	3566 A1	3904 B2	4409 C5	7426 C2
2110 B1	2433 B5	2902 C5	3119 C1	3406 C4	3427 A4	3448 C2	3469 B2	3567 A1	3905 B2	4411 C3	7427 C2
2111 B1	2434 B5	2903 C5	3120 B1	3407 C4	3428 A4	3449 A3	3470 C3	3569 A2	3906 C5	4413 C4	7428 B4
2114 C3	2435 B5	3100 C1	3121 B1	3408 B4	3429 A4	3450 A3	3471 C3	3570 A2	3907 C5	4414 C4	7429 B1
2115 C3	2436 B5	3101 C1	3122 A2	3409 C4	3430 A4	3451 A3	3472 C3	3571 A2	3908 C5	4415 C4	7430 C1
2400 B4	2566 A1	3102 C2	3124 C4	3410 B4	3431 A4	3452 A3	3475 B5	3572 A2	3909 C5	4416 C4	7431 B3
2402 B4	2567 A1	3103 C2	3125 C4	3411 B4	3432 A4	3453 A3	3476 B5	3573 A2	3910 C5	4417 C5	
2404 A3	2568 A2	3104 C1	3126 C3	3412 B4	3433 A4	3454 A3	3477 B5	3574 A2	3911 C5	4418 C4	
2406 B2	2569 A2	3105 C2	3127 C3	3413 B4	3434 A4	3455 A2	3484 C2	3575 A2	3912 C5	4419 C4	
2408 B2	2570 A2	3106 C2	3128 B1	3414 B4	3435 A4	3456 A3	3485 C3	3576 A2	3915 B1	4420 C5	
2409 B2	2571 A2	3107 C1	3349 C3	3415 B4	3436 A4	3457 A2	3486 C3	3577 A2	3916 B1	4422 C3	
2410 B2	2572 A2	3108 C4	3350 B1	3416 B4	3437 A4	3458 A3	3487 C2	3578 A3	3917 C5	4423 B2	
2411 C3	2573 A2	3109 C4	3351 B1	3417 B4	3438 A3	3459 B2	3491 C5	3579 A5	3918 C5	4451 C3	

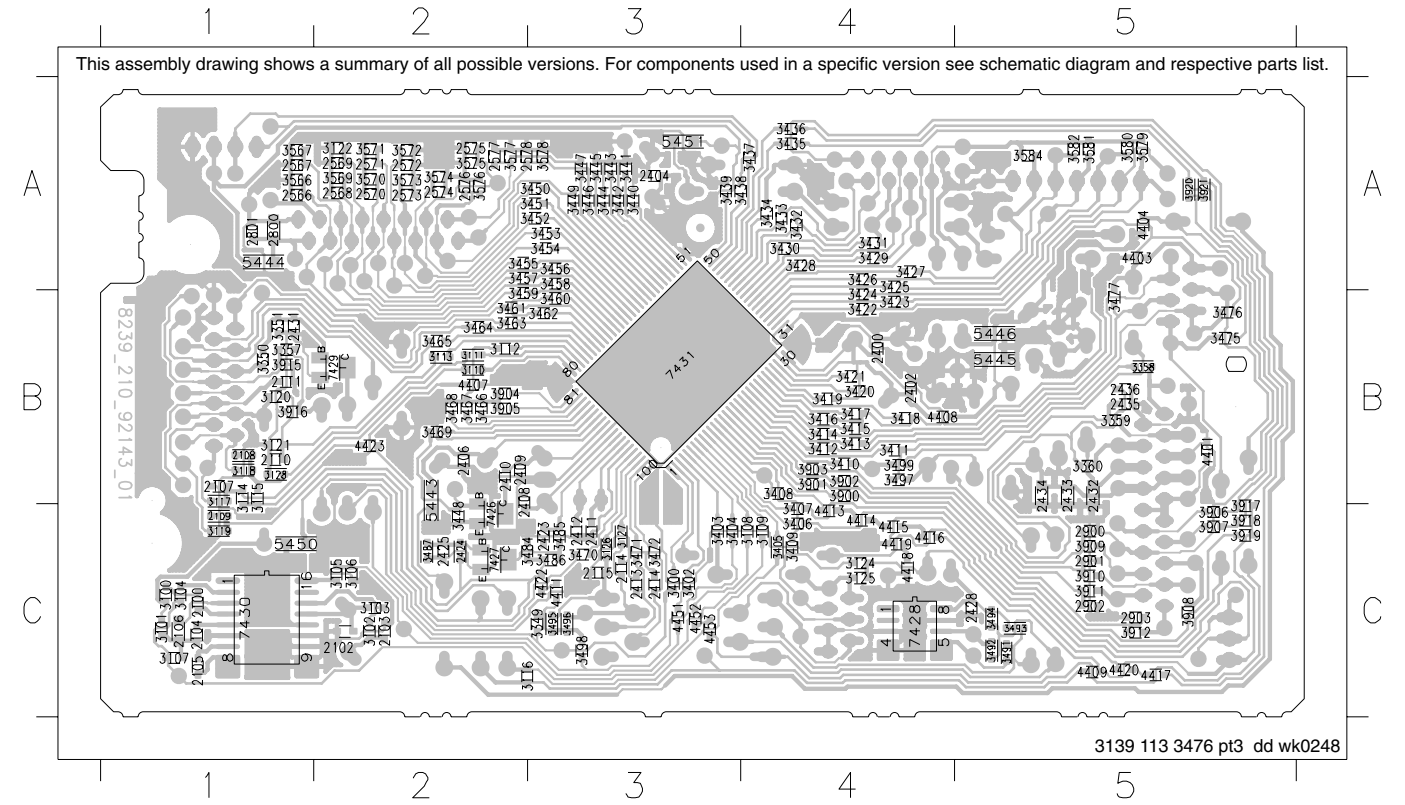

CONTROL BOARD - CIRCUIT DIAGRAM

1200 A14	1212 D1	2106 H1	2400 D8	2408 C5	2424 H7	2435 D12	2572 C12	2801 A10	3103 G3	3111 A6	3119 G13	3128 H11	3400 D6	3408 D7	3416 D8	3424 C9	3432 C9	3440 A8	3448 D4	3456 A7	3464 A6	3472 E5	3491 H9	3499 F7	3574 A11	3582 B4	3906 E13	3916 H12	5401 C5	5451 A9	7430 G1
1201 C14	1213 E1	2107 H11	2401 D9	2409 C4	2425 H7	2436 D12	2573 C12	2900 F12	3104 H5	3112 A6	3120 G12	3349 F9	3401 D6	3409 D7	3417 D8	3425 C9	3433 B9	3441 A8	3449 A8	3457 A7	3465 A6	3475 E2	3492 H9	3566 A13	3575 A11	3584 B4	3907 E13	3917 D12	5402 F3	5450 A9	7431 C8
1202 F14	2100 F2	2108 H11	2402 D9	2410 C4	2428 H9	2566 C13	2574 C11	2901 F12	3105 H5	3113 A6	3121 H12	3350 F9	3402 D6	3410 D7	3418 D8	3426 C9	3434 B9	3442 A8	3450 A7	3458 A7	3466 B4	3476 E2	3493 H9	3567 A13	3576 A11	3900 D7	3908 E13	3918 D12	5443 B3	5451 F8	
1203 F14	2101 F2	2109 H12	2403 D9	2411 C5	2430 F7	2567 C13	2575 C11	2902 F12	3106 H6	3114 F11	3122 A13	3351 F9	3403 D6	3411 D7	3419 D8	3427 C9	3435 B9	3443 A8	3451 A7	3459 A7	3467 B4	3477 E3	3494 H9	3569 A13	3577 A11	3901 D7	3909 E13	3919 D12	5444 A10	5451 F8	
1204 B1	2102 F3	2110 H12	2404 B8	2412 C5	2431 F9	2568 C13	2576 C11	2903 F13	3107 H6	3115 F11	3124 B2	3357 G12	3404 D6	3412 D7	3420 D8	3428 C9	3436 B9	3444 A8	3452 A7	3460 A7	3468 B4	3478 H7	3495 B2	3570 A12	3578 A11	3902 D7	3910 F13	3920 F13	5445 E9	7426 D4	
1207 A4	2103 F4	2111 G13	2405 B9	2413 C5	2432 D13	2569 C13	2577 C11	3100 F2	3108 D6	3116 F12	3125 B2	3358 C13	3405 D7	3413 D7	3421 D8	3429 C9	3437 B9	3445 A8	3453 A7	3461 A7	3469 B4	3479 H6	3496 B2	3571 A12	3579 A4	3903 D7	3911 F13	3921 F13	5446 D9	7427 H6	
1210 A3	2104 G5	2114 C2	2406 C4	2414 E4	2433 D13	2570 C12	2578 C11	3101 F2	3109 D7	3117 G13	3126 D5	3359 D13	3406 D7	3414 D8	3422 C9	3430 C9	3438 B9	3446 A8	3454 A7	3462 A7	3470 D5	3486 H7	3497 D10	3572 A12	3580 A4	3904 B4	3912 F13	4401 E14	5448 G8	7428 H8	
1211 A1	2105 H1	2115 C2	2407 C4	2423 H6	2434 D13	2571 C12	2800 A10	3102 F4	3110 A6	3118 G13	3127 D5	3360 D13	3407 D7	3415 D8	3423 C9	3431 C9	3439 B9	3447 A8	3455 A7	3463 A7	3471 E5	3487 H7	3498 F11	3573 A12	3581 A4	3905 B4	3915 H13	5400 C5	5450 F5	7429 F9	

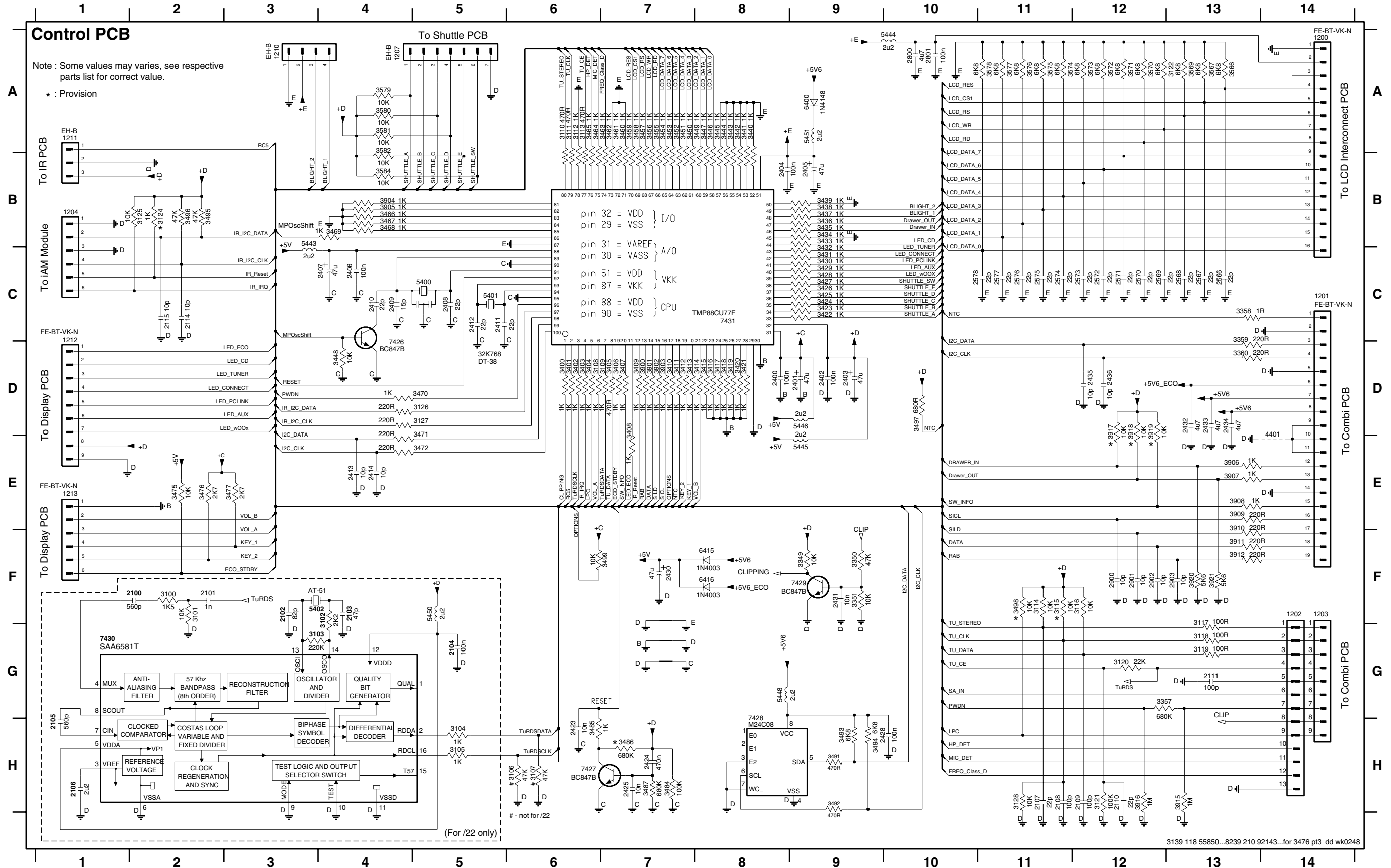

DISPLAY BOARD - COMPONENT LAYOUT

1206 A2	1224 C5	1403 D3	1407 E4	1411 C5	6401 E2	6405 E5	9406 D5	9410 B6	9414 B6
1208 A6	1400 A1	1404 E2	1408 E5	1412 B6	6402 E3	9400 A6	9407 C5	9411 D4	9417 D3
1209 E6	1401 B1	1405 E3	1409 E1	1413 B6	6403 E4	9403 C6	9408 D5	9412 D4	
1223 D6	1402 C2	1406 E4	1410 D5	1414 A6	6404 E5	9404 D6	9409 D4	9413 D4	

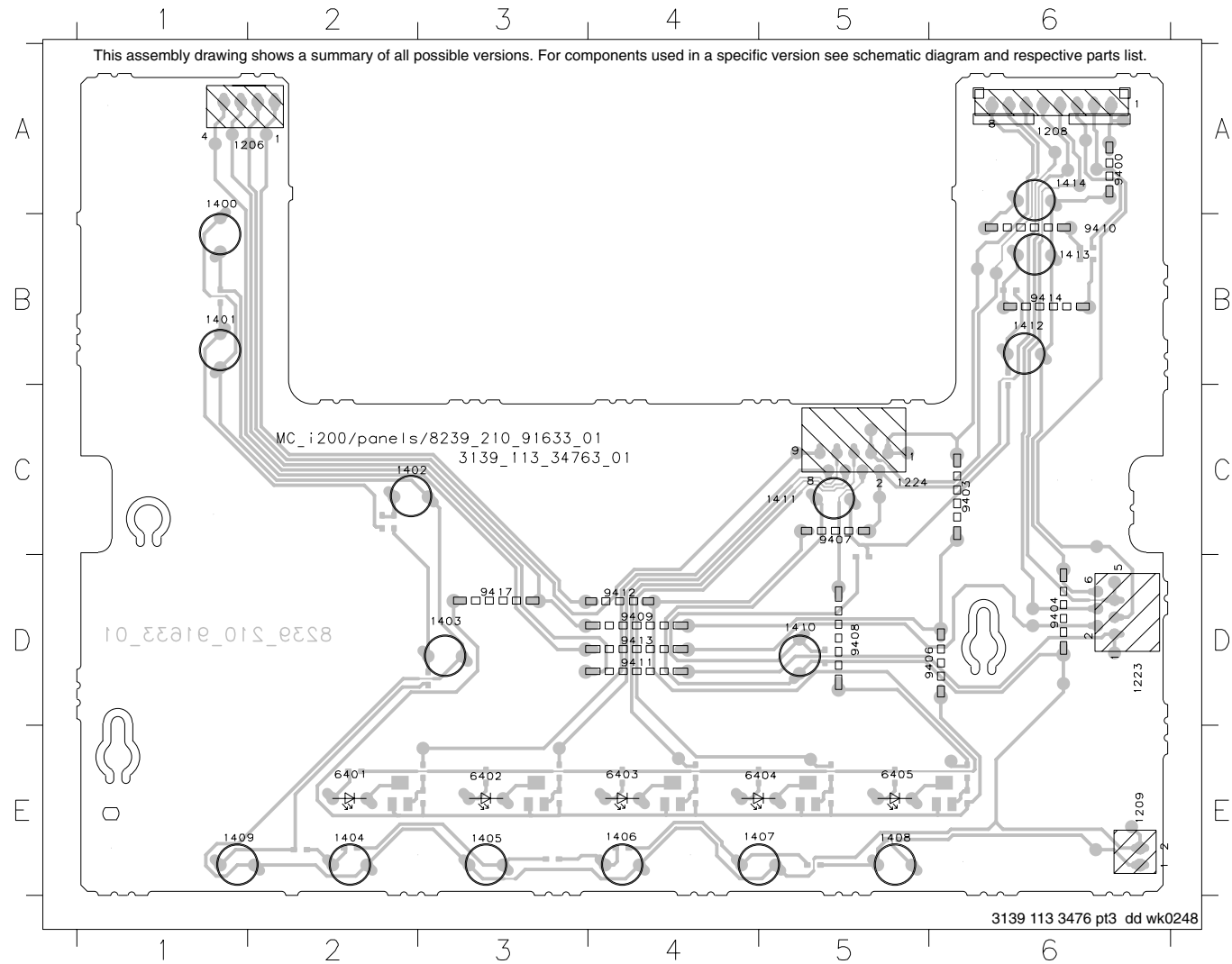

DISPLAY BOARD - CHIP LAYOUT

2461 D2	3504 E3	3507 E5	3510 C5	3517 B1	3520 D2	3537 E5	3540 E4	3543 E3	3546 E2	3549 E2	7403 E3
3502 E2	3505 E4	3508 D4	3511 B6	3518 B1	3535 E4	3538 E4	3541 E3	3544 E2	3547 E1	7401 E5	7404 E2
3503 E2	3506 E5	3509 C5	3516 B1	3519 B1	3536 E4	3539 E4	3542 E3	3545 E2	3548 E1	7402 E4	7405 E1

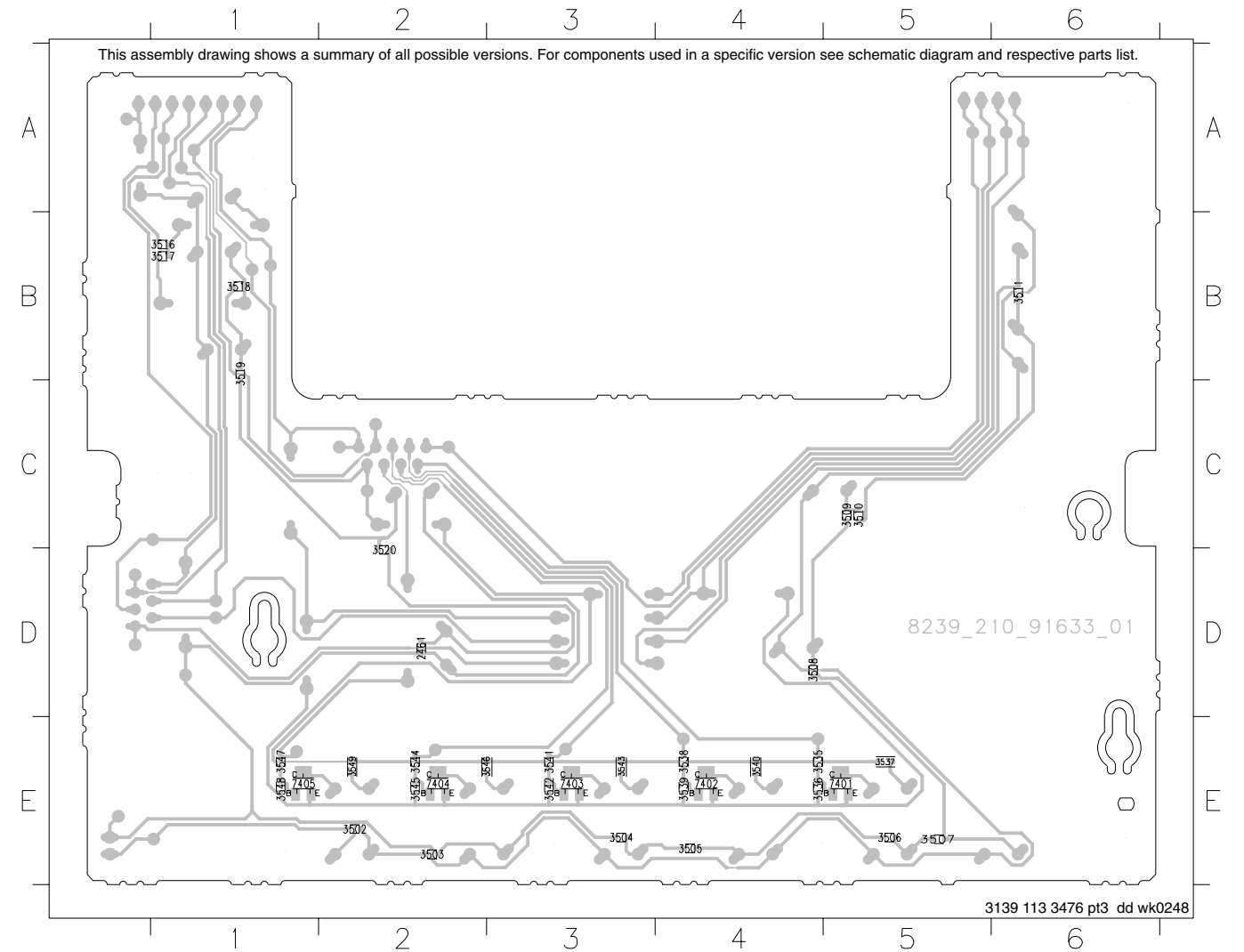

DISPLAY BOARD - CIRCUIT DIAGRAM

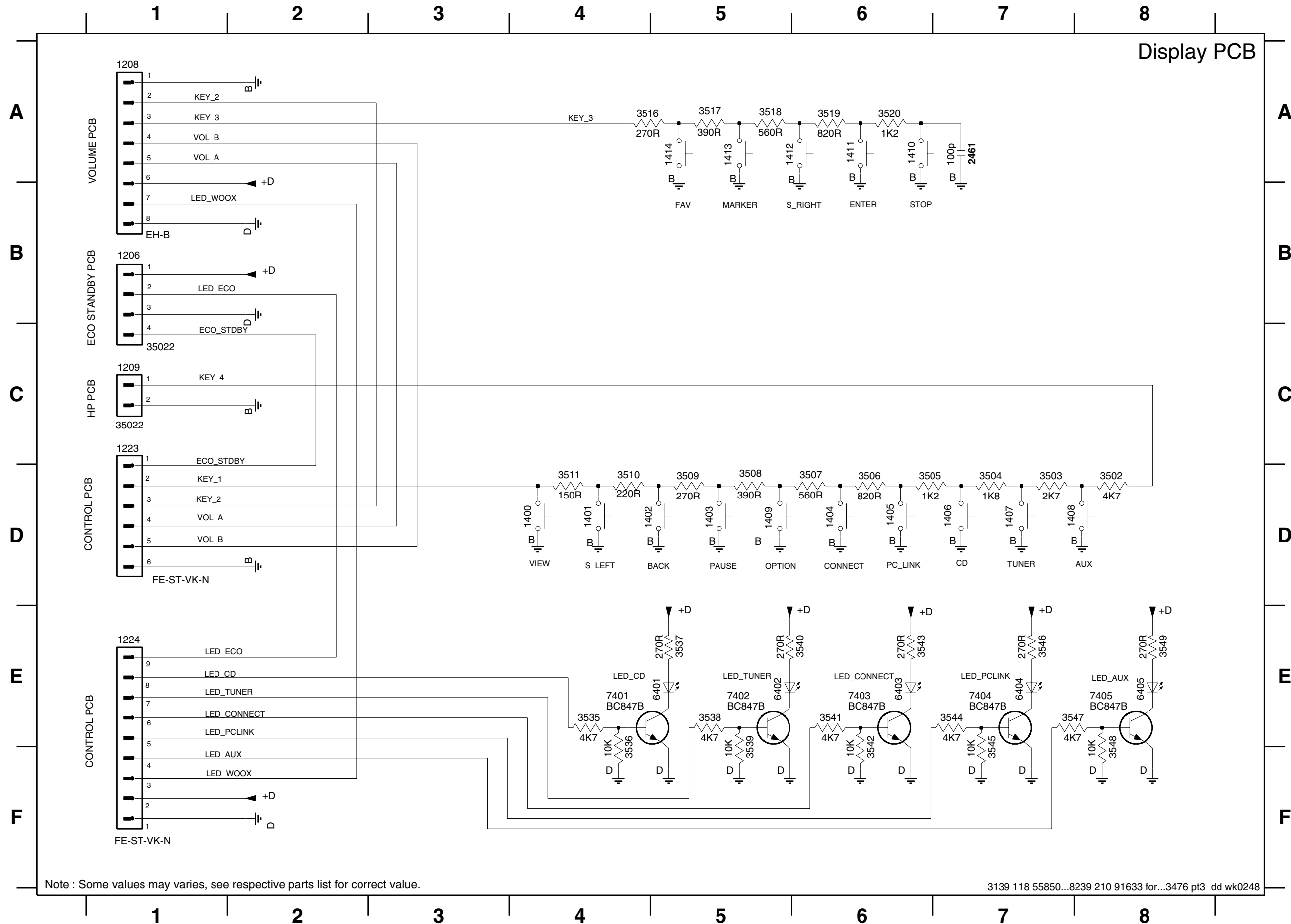

- 1206 B1
- 1208 A1
- 1209 C1
- 1223 C1
- 1224 E1
- 1400 D4
- 1401 D4
- 1402 D4
- 1403 D5
- 1404 D6
- 1405 D6
- 1406 D7
- 1407 D7
- 1408 D7
- 1409 D5
- 1410 A6
- 1411 A6
- 1412 A5
- 1413 A5
- 1414 A5
- 2461 A7
- 3502 D8
- 3503 D7
- 3504 D7
- 3505 D6
- 3506 D6
- 3507 D6
- 3508 D5
- 3509 D5
- 3510 D4
- 3511 D4
- 3516 A4
- 3517 A5
- 3518 A5
- 3519 A6
- 3520 A6
- 3535 E4
- 3536 F4
- 3537 E5
- 3538 E5
- 3539 F5
- 3540 E6
- 3541 E6
- 3542 F6
- 3543 E6
- 3544 E7
- 3545 F7
- 3546 E7
- 3547 E7
- 3548 F8
- 3549 E8
- 6401 E5
- 6402 E5
- 6403 E6
- 6404 E7
- 6405 E8
- 7401 E4
- 7402 E5
- 7403 E6
- 7404 E7
- 7405 E8

Note : Some values may varies, see respective parts list for correct value.

3139 118 55850...8239 210 91633 for...3476 pt3 dd wk0248

ECO STANDBY BOARD - COMPONENT LAYOUT

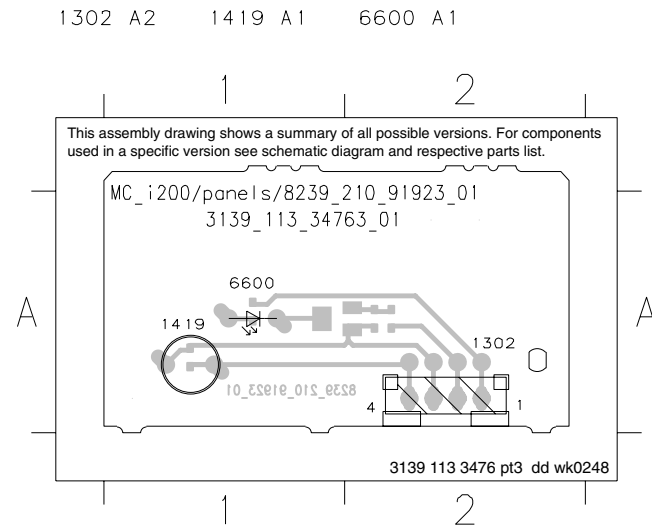

ECO STANDBY BOARD - CHIP LAYOUT

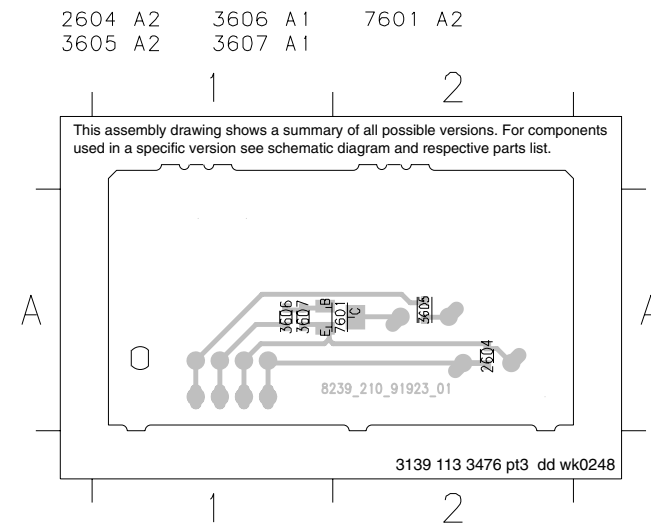

ECO STANDBY BOARD - CIRCUIT DIAGRAM

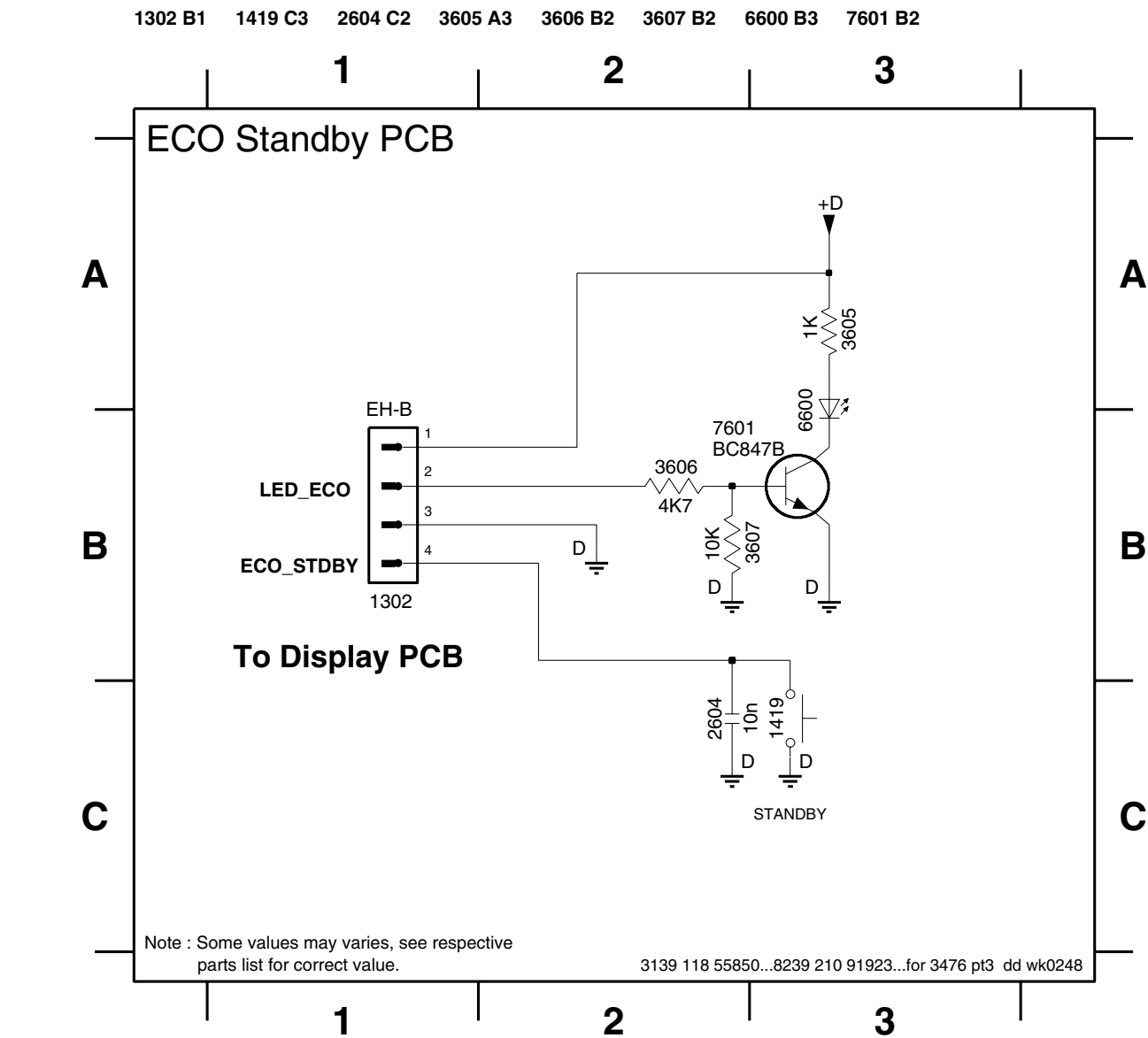

INFRA RECEIVER BOARD - COMPONENT LAYOUT

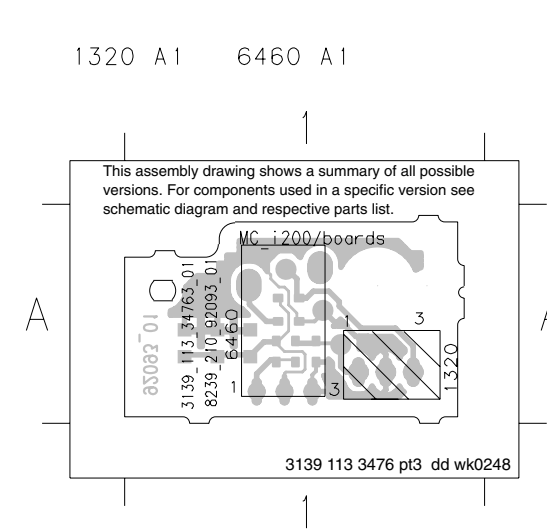

INFRA RECEIVER BOARD - CHIP LAYOUT

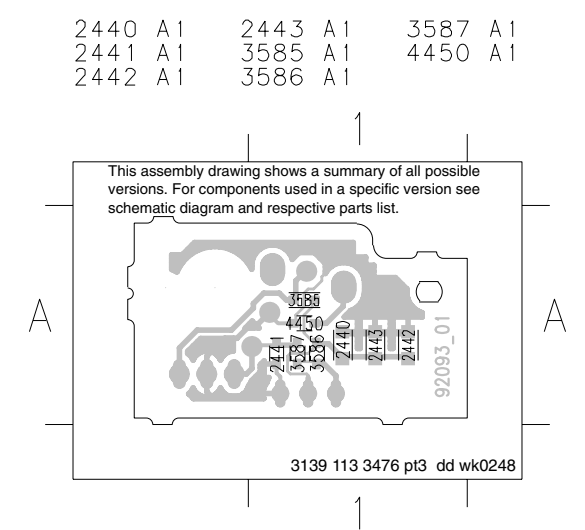

INFRA RECEIVER BOARD - CIRCUIT DIAGRAM

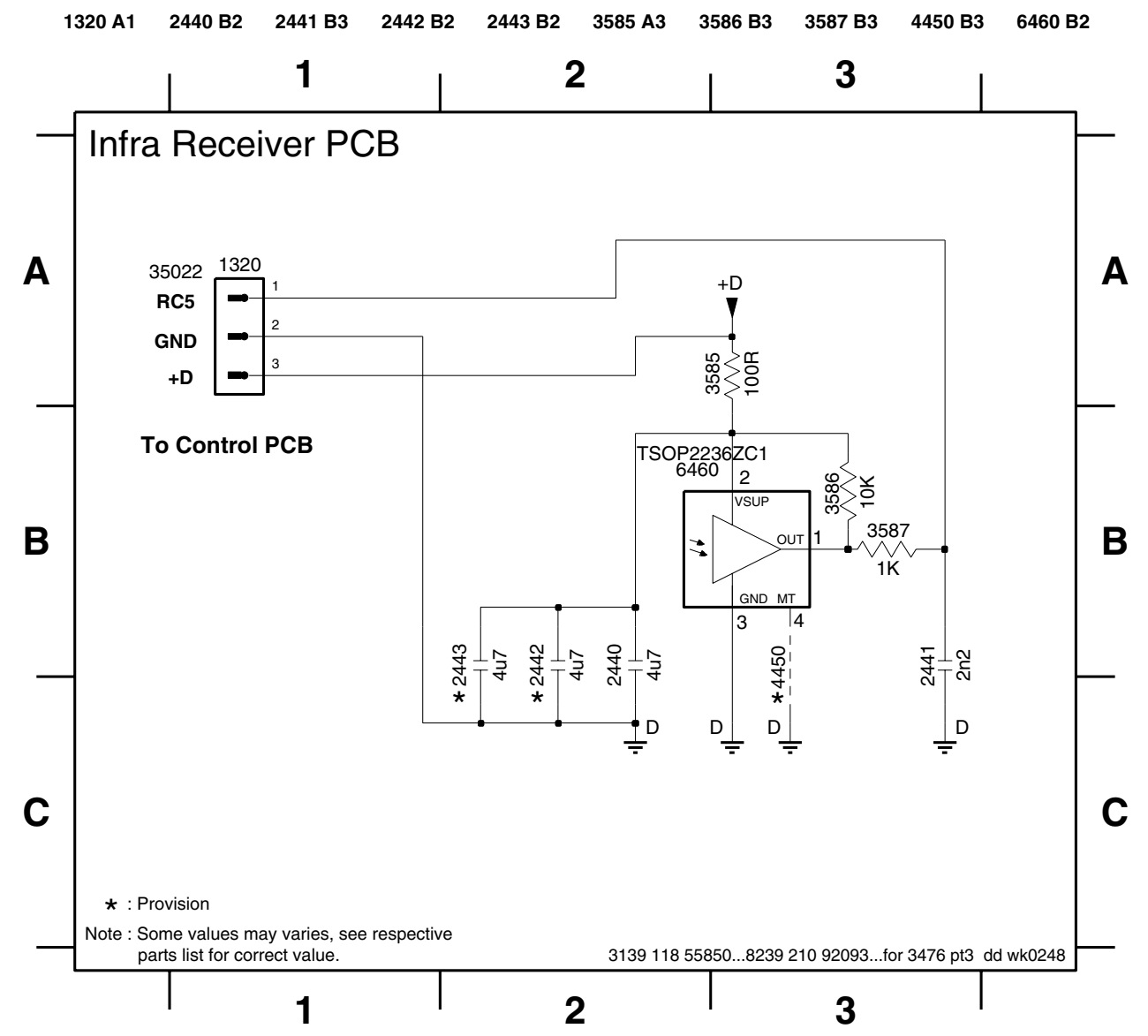

HEADPHONE BOARD - COMPONENT LAYOUT

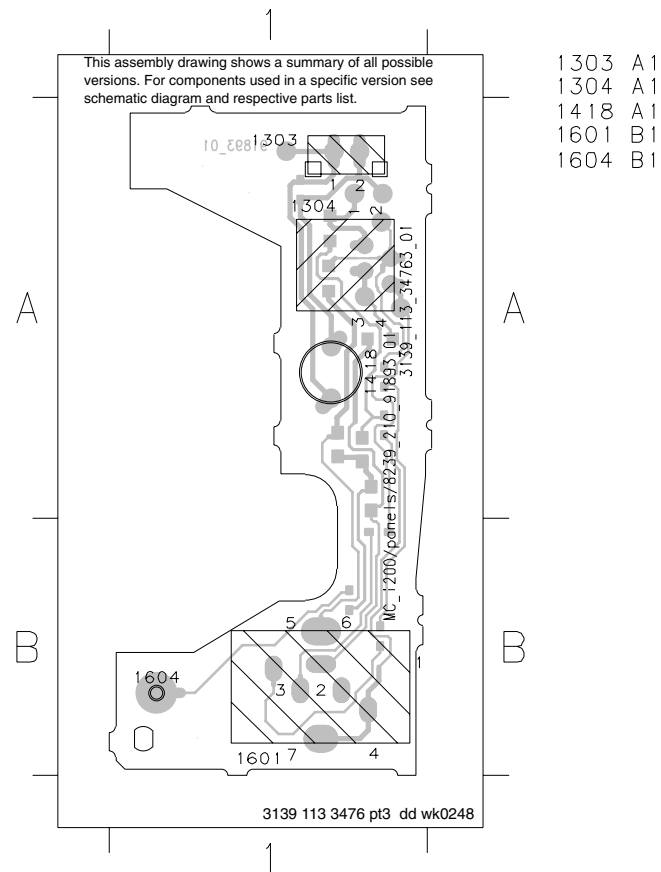

- 1303 A1
- 1304 A1
- 1418 A1
- 1601 B1
- 1604 B1

HEADPHONE BOARD - CHIP LAYOUT



- 2605 A1
- 2606 A1
- 2607 A1
- 2608 A1
- 4441 A1
- 4442 B1
- 4443 B1
- 4444 A1
- 4445 A1
- 4446 B1
- 5600 A1
- 5601 A1
- 5602 A1

SHUTTLE BOARD - COMPONENT LAYOUT

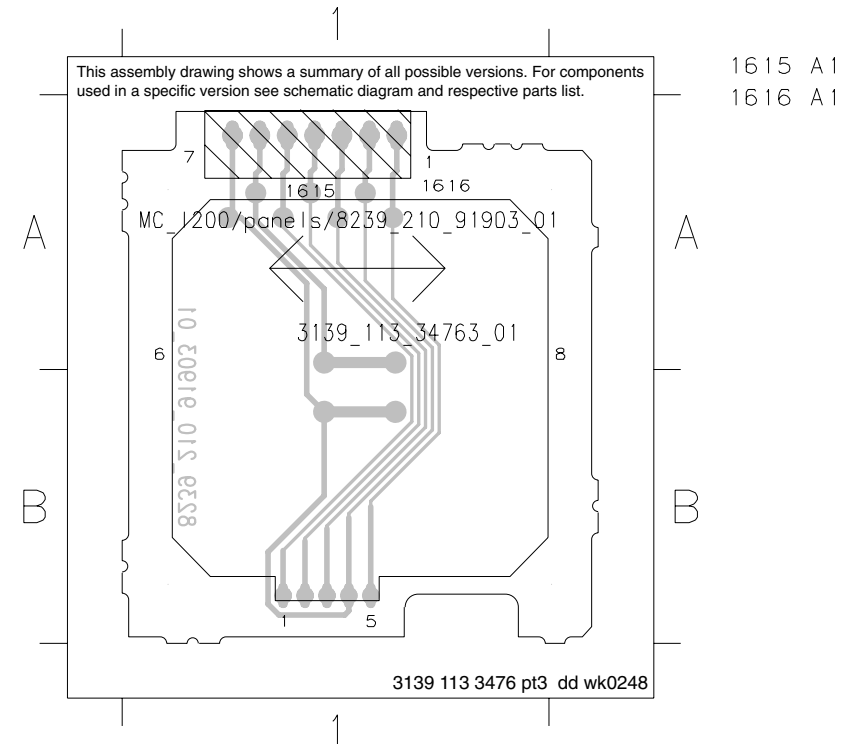

- 1615 A1
- 1616 A1

SHUTTLE BOARD - CIRCUIT DIAGRAM

- 1615 A1
- 1616 A3

HEADPHONE BOARD - CIRCUIT DIAGRAM

- 1303 B1
- 1304 A1
- 1418 B2
- 1601 A3
- 1604 B2
- 2605 A2
- 2606 A2
- 2607 A2
- 2608 B2
- 5600 A2
- 5601 A2
- 5602 A2

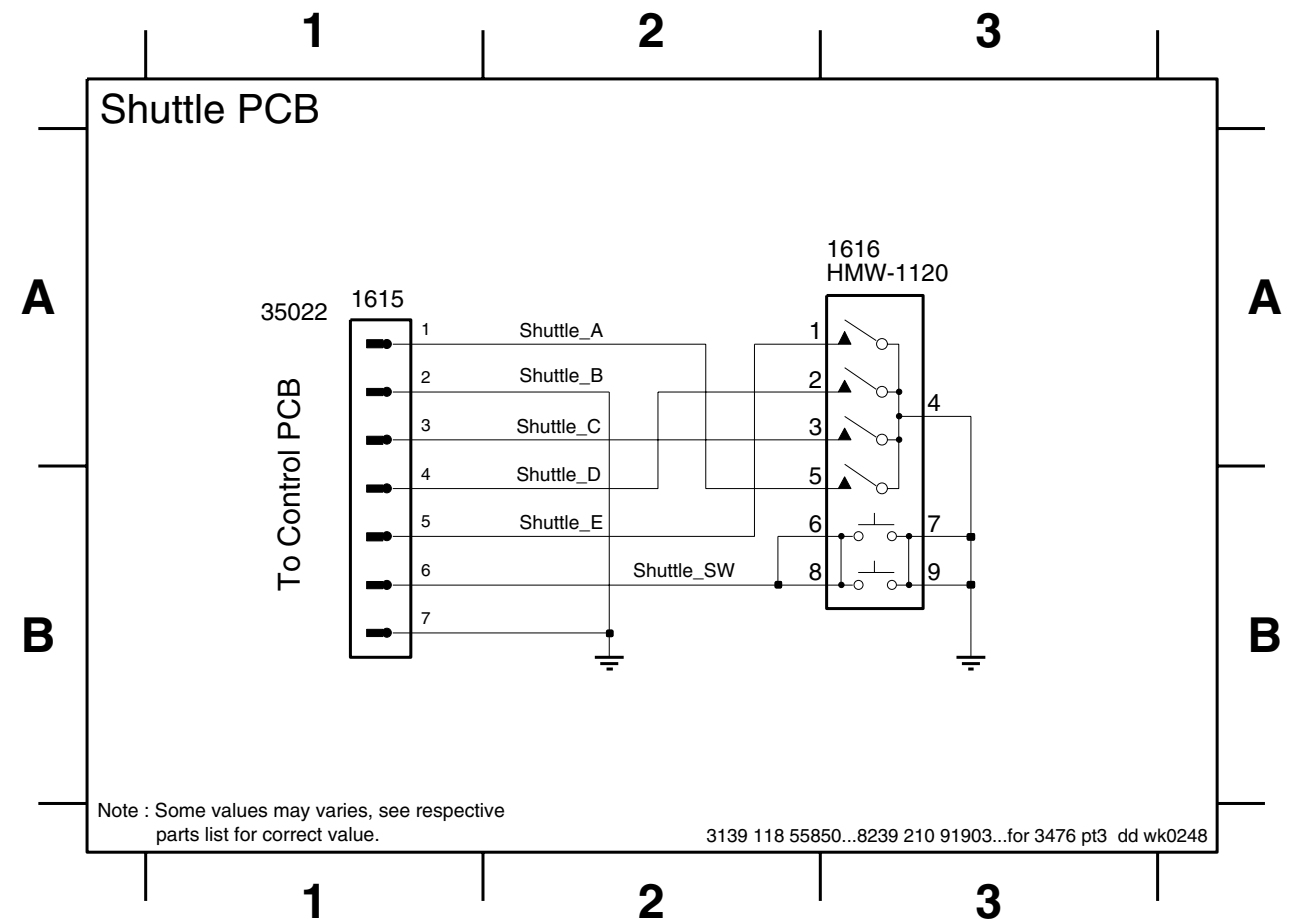
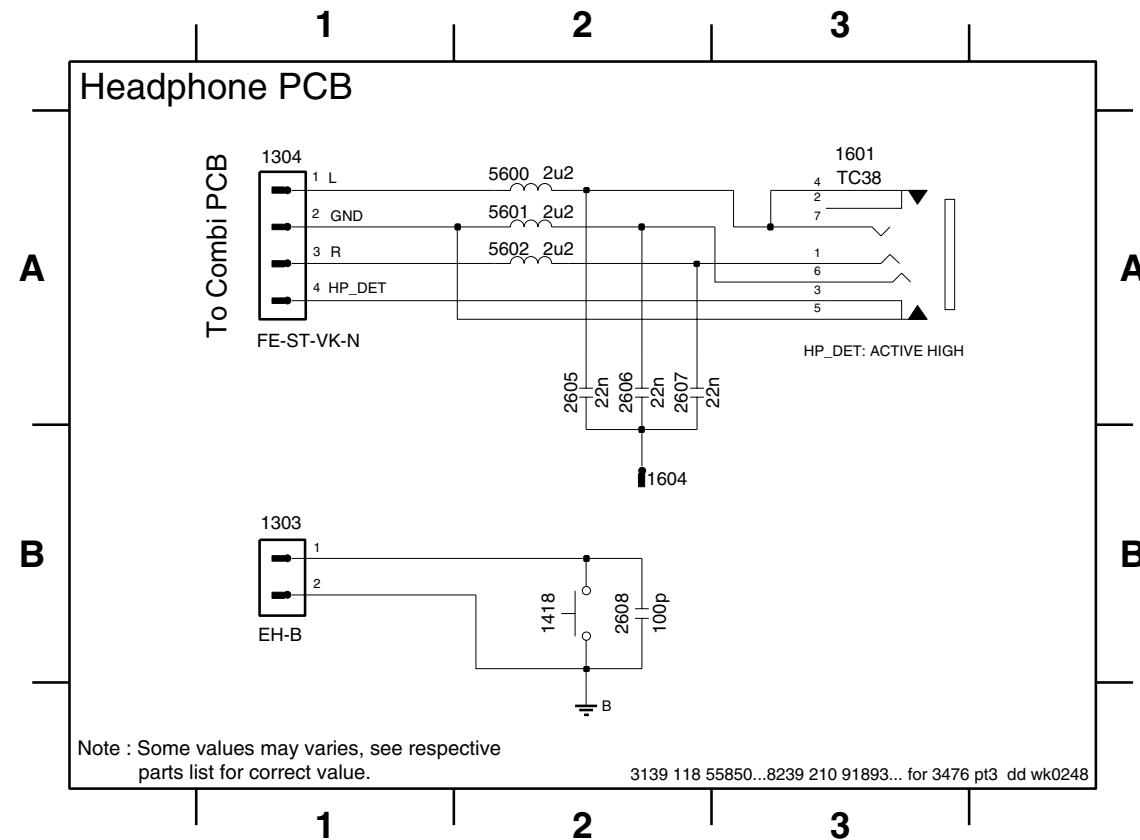

LCD INTERCONNECT BOARD - COMPONENT LAYOUT

1700 A2 1701 A2

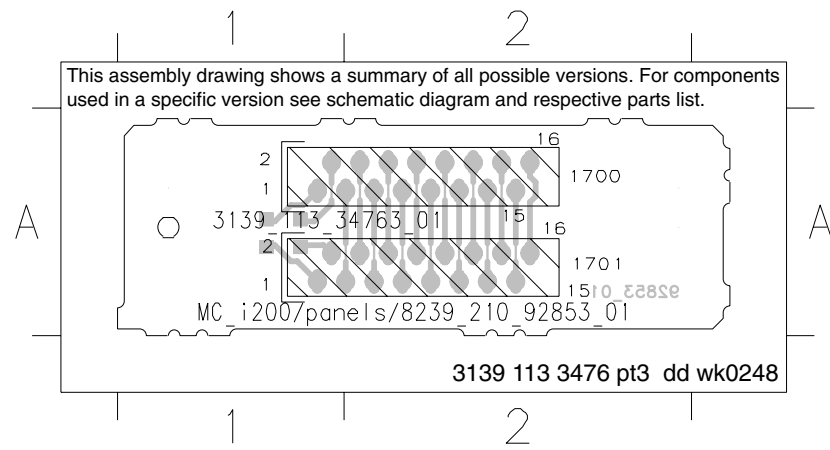

LCD INTERCONNECT BOARD - CHIP LAYOUT

4701 A2 4702 A2 5701 A2 5702 A2

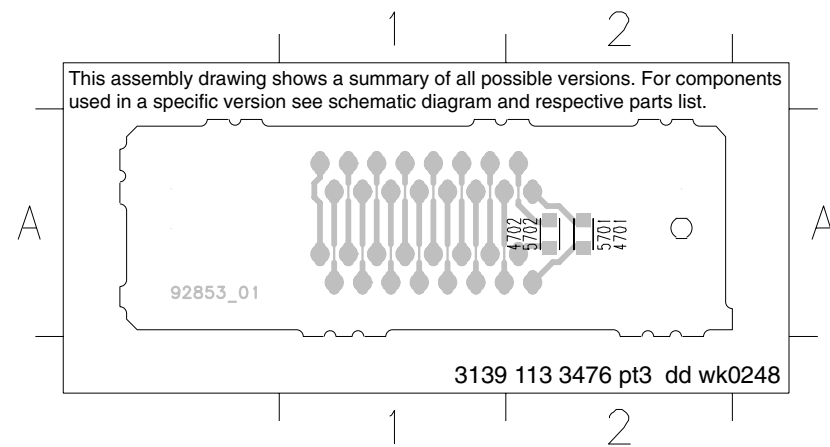

LCD INTERCONNECT BOARD - CIRCUIT DIAGRAM

1700 A1 1701 A3 4701 A2 4702 A2 5701 A2 5702 A2

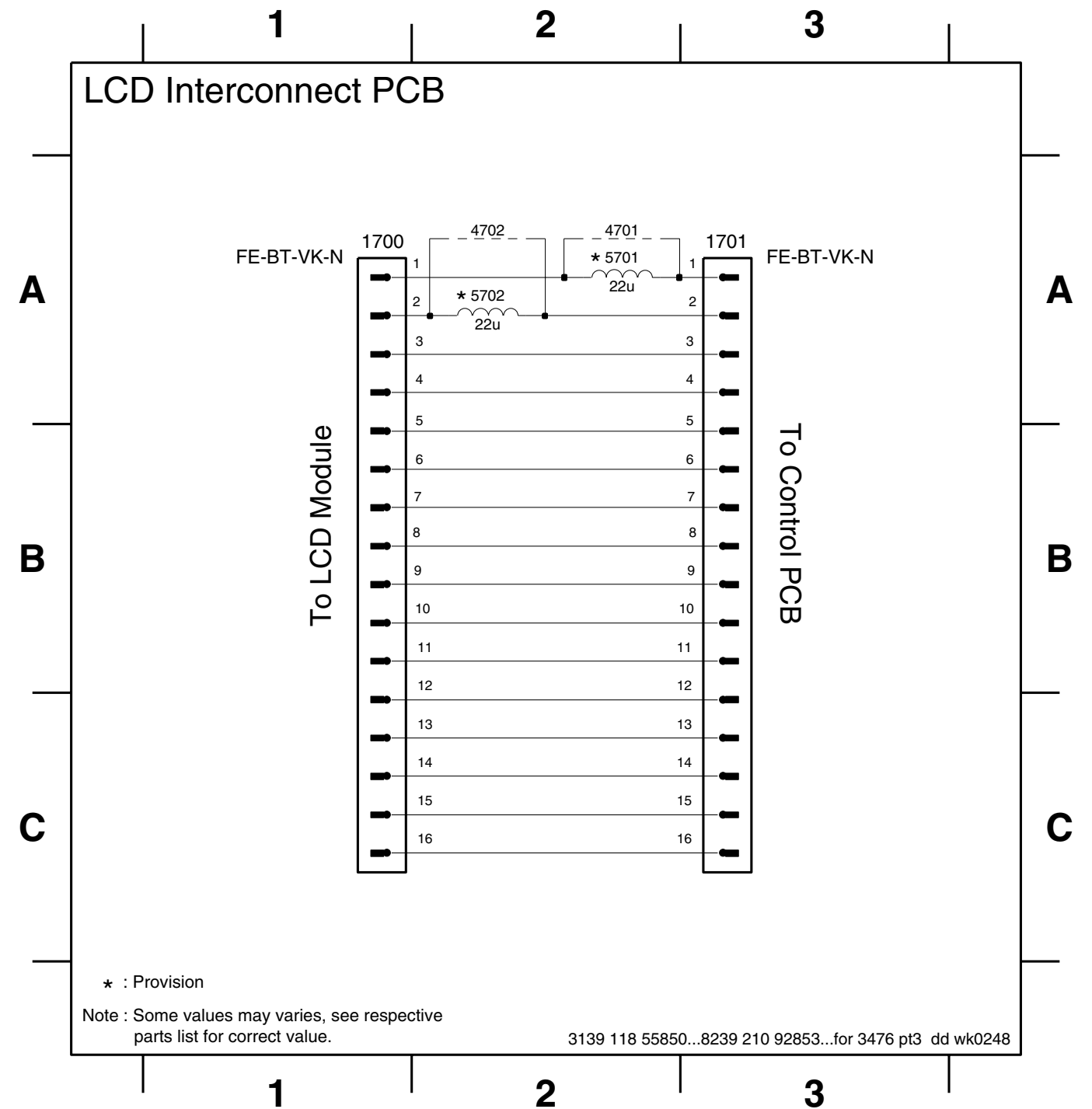

LCD BACK LIGHT BOARD - COMPONENT LAYOUT

10 A1 6501 A1 6503 A2 6505 A2 6507 A3 6509 A4
 6500 A1 6502 A2 6504 A2 6506 A3 6508 A4

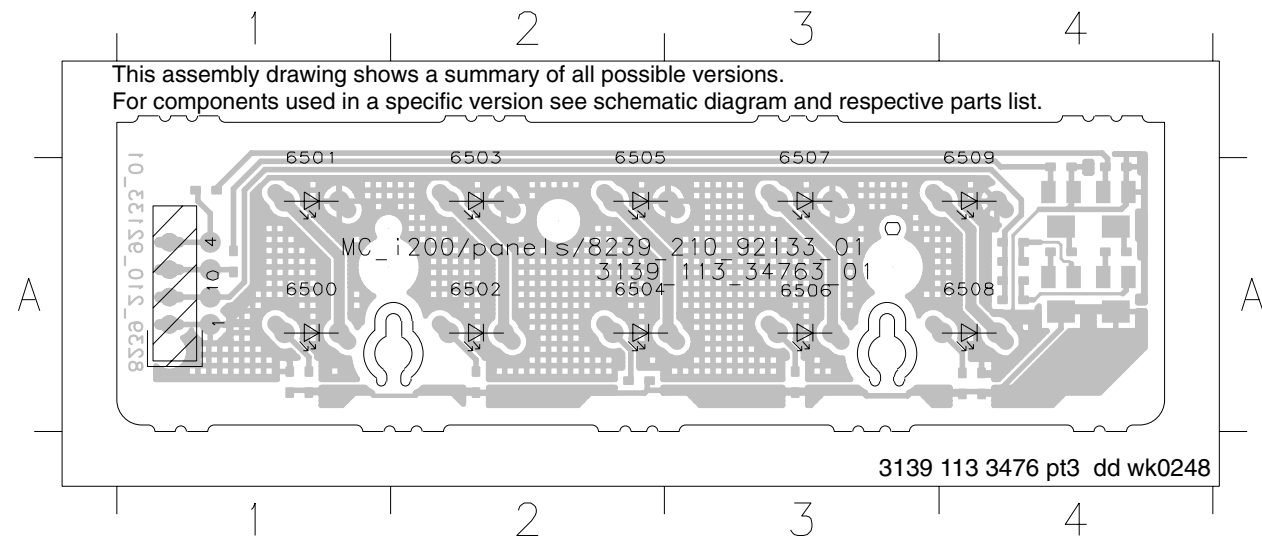

LCD BACK LIGHT BOARD - CHIP LAYOUT

2300 A4 3301 A1 3304 A4 3307 A4 3310 A4 3313 A2 7301 A1
 2301 A1 3302 A1 3305 A1 3308 A1 3311 A3 3314 A1 7302 A1
 3300 A1 3303 A1 3306 A1 3309 A1 3312 A3 7300 A1 7303 A1

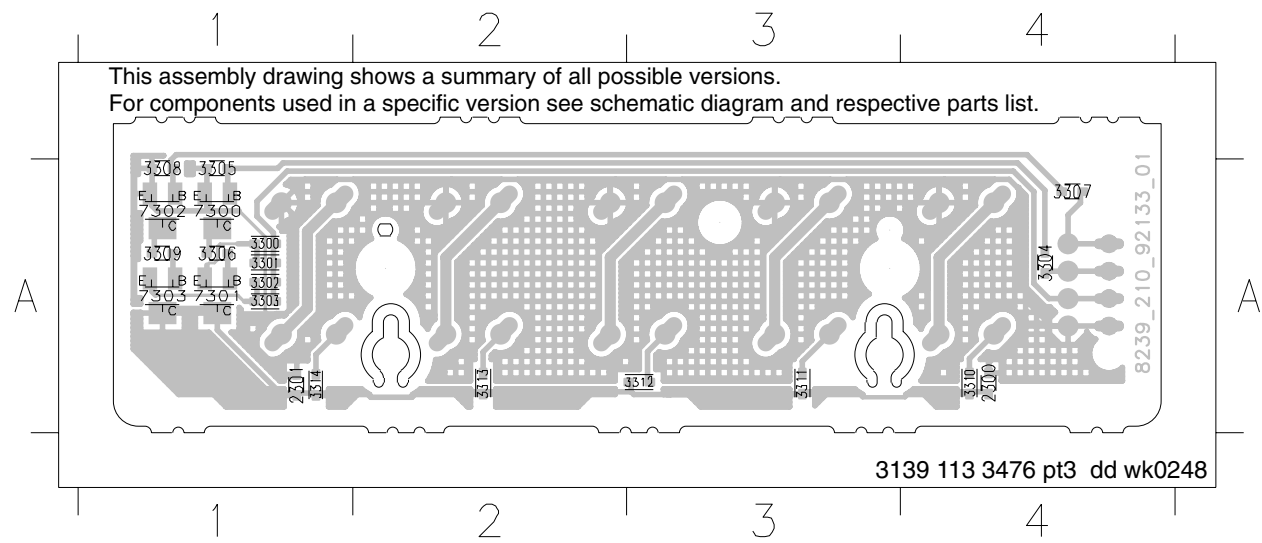

LCD BACK LIGHT BOARD - CIRCUIT DIAGRAM

10 A1 3301 A2 3305 B2 3309 B3 3313 C2 6502 D2 6506 D2 7300 B2
 2300 D1 3302 A2 3306 B2 3310 C1 3314 C3 6503 D2 6507 D2 7301 B2
 2301 D3 3303 A3 3307 B2 3311 C2 6500 D1 6504 D2 6508 D3 7302 B3
 3300 A2 3304 B2 3308 B3 3312 C2 6501 D1 6505 D2 6509 D3 7303 B3

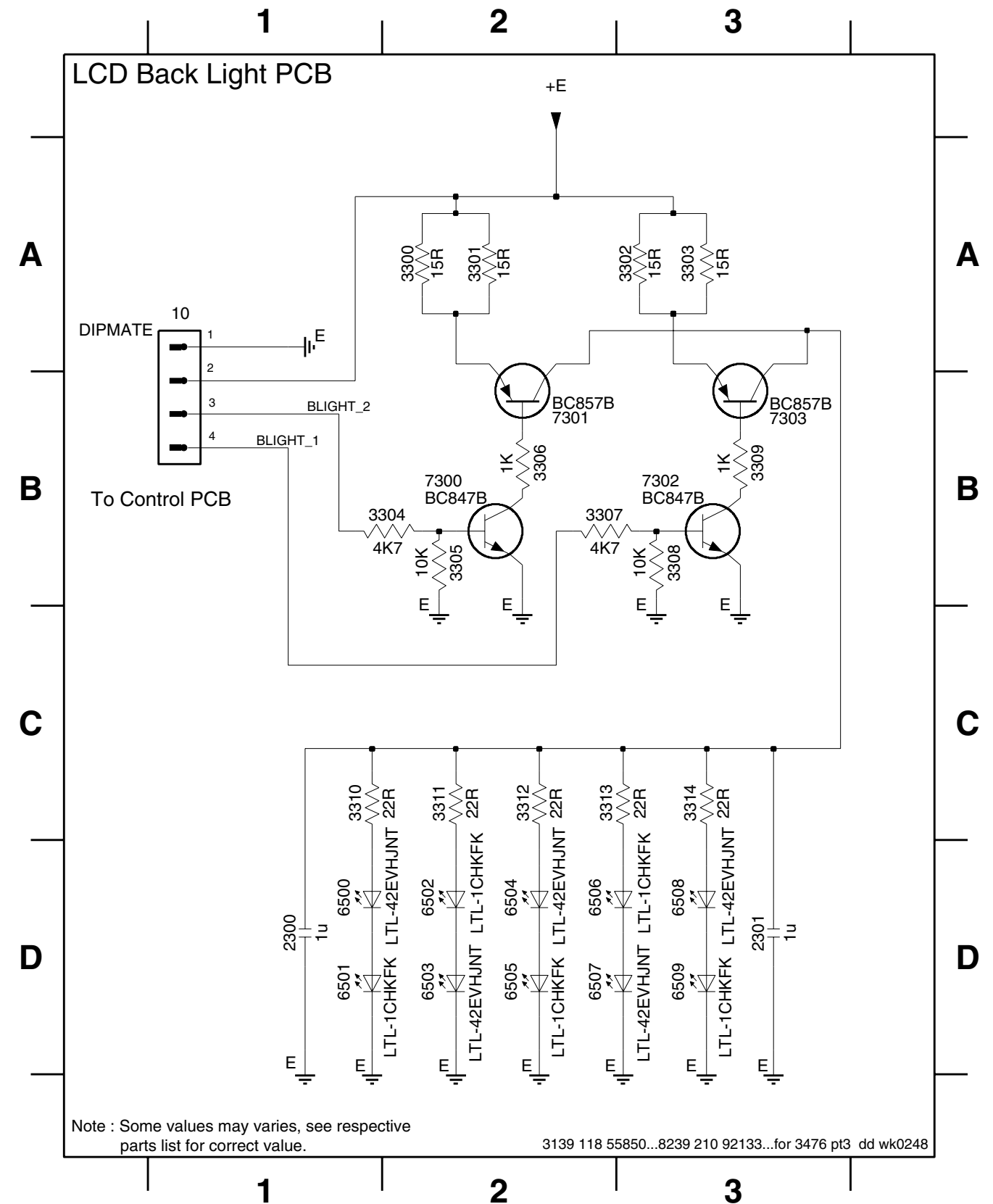

VOLUME BOARD - COMPONENT LAYOUT

1301 A2 1415 A2 1416 A1 1417 A1 1611 A3 6605 A1

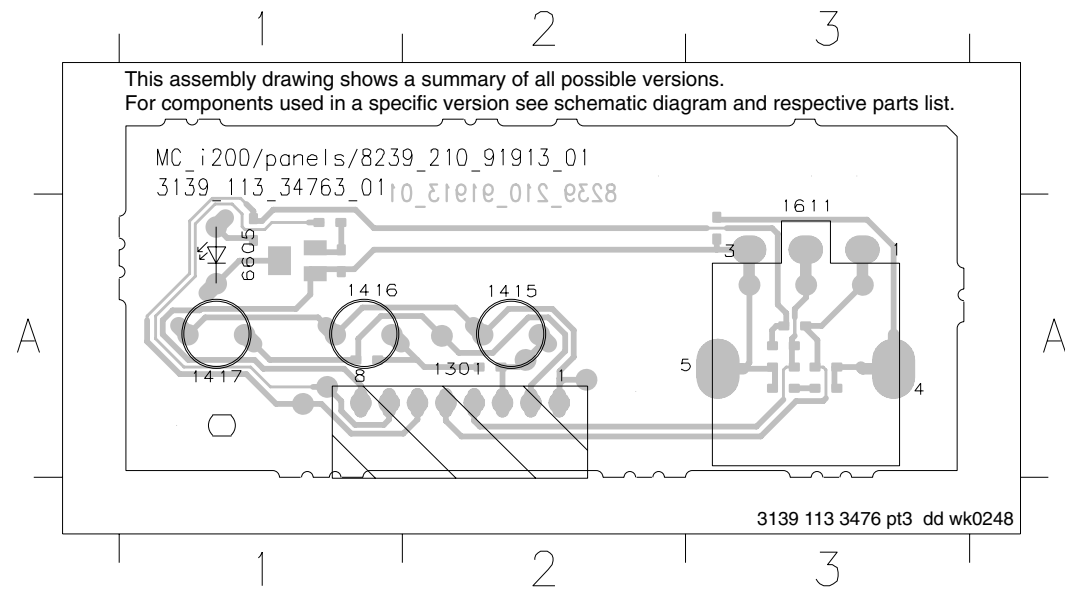

VOLUME BOARD - CHIP LAYOUT

2463 A1 3601 A2 3604 A3 4425 A1 7600 A3
 2464 A1 3602 A3 3608 A1 4432 A1
 3600 A3 3603 A3 3609 A1 4433 A1

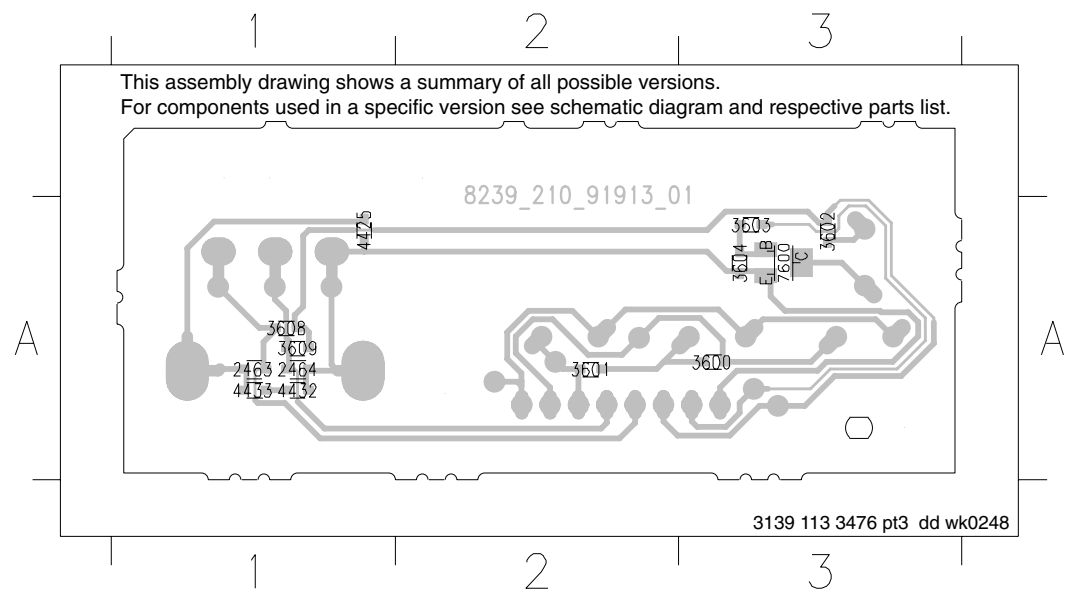

VOLUME BOARD - CIRCUIT DIAGRAM

1301 B1 1416 A3 1611 B3 2464 B2 3601 A3 3603 D2 3608 B2 6605 D3
 1415 A3 1417 A2 2463 B2 3600 A2 3602 C3 3604 D2 3609 B2 7600 D2

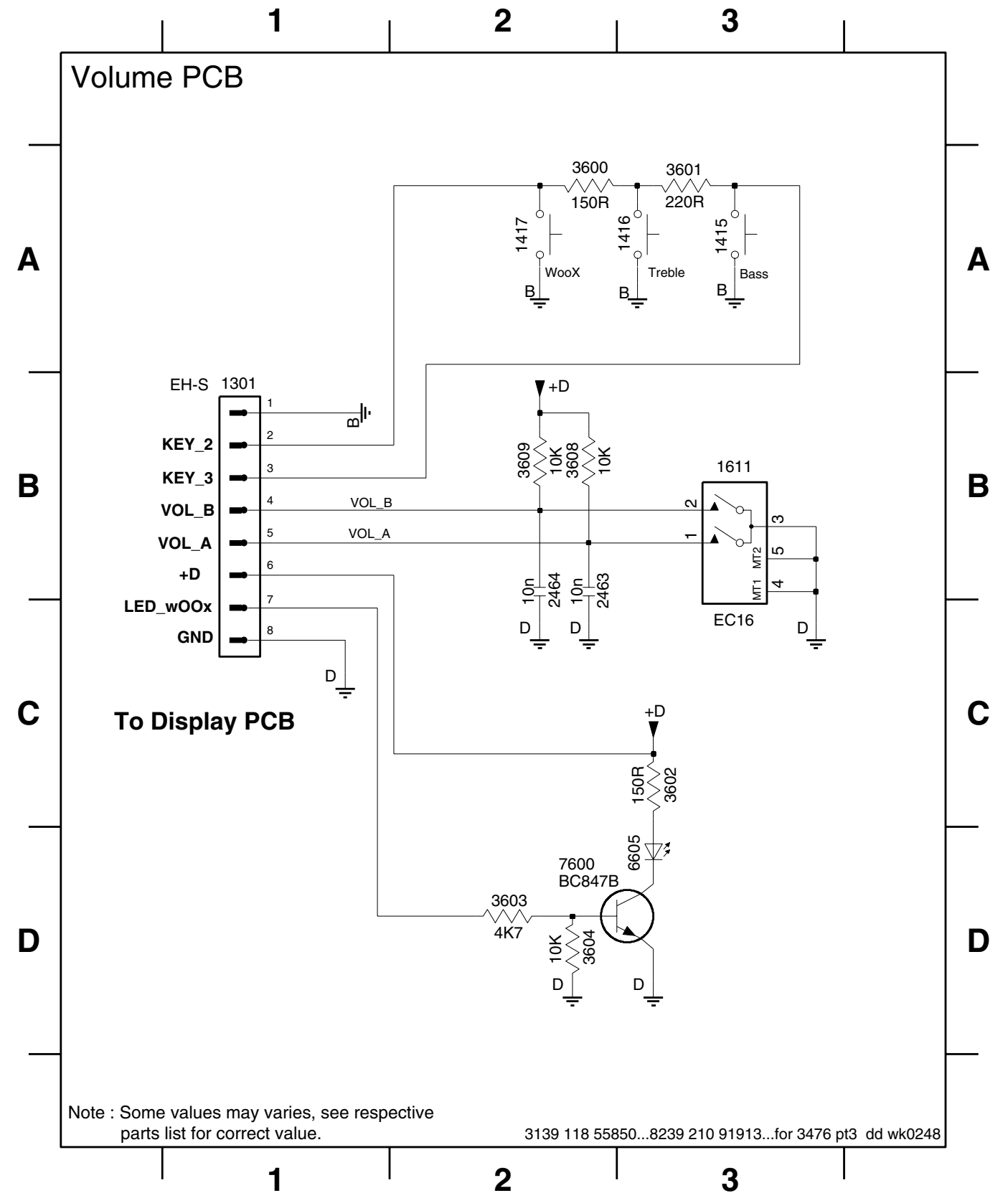

ELECTRICAL PARTS LIST - FRONT BOARD**MISCELLANEOUS**

1200	2422 025 14526	Flex Connector 16P	2400	2238 586 59812	100nF 50V
1201	4822 265 11553	Flex Connector 19P	2401	4822 124 80483	47uF 20% 6,3V
1203	2422 025 14518	Flex Connector 9P	2402	2238 586 59812	100nF 50V
1204	4822 267 10731	Flex Connector 6P	2403	4822 124 80483	47uF 20% 6,3V
1212	2422 025 14518	Flex Connector 9P	2404	2238 586 59812	100nF 50V
1213	4822 267 10731	Flex Connector 6P	2405	4822 124 80483	47uF 20% 6,3V
1223	4822 265 11207	Flex Connector 6P	2406	2238 586 59812	100nF 50V
1224	4822 265 11531	Flex Connector 9P	2407	4822 124 80483	47uF 20% 6,3V
1304	4822 265 11183	Flex Connector 4P	2408	4822 122 33761	22pF 5% 50V
1400	4822 276 13775	Tact Switch	2409	4822 122 33752	15pF 5% 50V
1401	4822 276 13775	Tact Switch	2410	4822 122 33761	22pF 5% 50V
1402	4822 276 13775	Tact Switch	2411	4822 122 33761	22pF 5% 50V
1403	4822 276 13775	Tact Switch	2412	4822 122 33761	22pF 5% 50V
1404	4822 276 13775	Tact Switch	2413	4822 122 33741	10pF 10% 50V
1405	4822 276 13775	Tact Switch	2414	4822 122 33741	10pF 10% 50V
1406	4822 276 13775	Tact Switch	2423	5322 126 11583	10nF 10% 50V
1407	4822 276 13775	Tact Switch	2424	3198 017 44740	470nF 10V
1408	4822 276 13775	Tact Switch	2425	5322 126 11583	10nF 10% 50V
1409	4822 276 13775	Tact Switch	2428	2238 586 59812	100nF 50V
1410	4822 276 13775	Tact Switch	2430	4822 124 80483	47uF 20% 6,3V
1411	4822 276 13775	Tact Switch	2431	5322 126 11583	10nF 10% 50V
1412	4822 276 13775	Tact Switch	2432	2020 552 96305	4,7uF +80/-20% 10V
1413	4822 276 13775	Tact Switch	2433	2020 552 96305	4,7uF +80/-20% 10V
1414	4822 276 13775	Tact Switch	2434	2020 552 96305	4,7uF +80/-20% 10V
1415	4822 276 13775	Tact Switch	2435	4822 122 33741	10pF 10% 50V
1416	4822 276 13775	Tact Switch	2436	4822 122 33741	10pF 10% 50V
1417	4822 276 13775	Tact Switch	2440	2020 552 96305	4,7uF +80/-20% 10V
1418	4822 276 13775	Tact Switch	2441	4822 126 14238	2,2nF 50V
1419	4822 276 13775	Tact Switch	2461	2020 552 94427	100pF 5% 50V
1601	2422 026 05059	Headphone Socket	2463	5322 126 11583	10nF 10% 50V
1611	2422 129 16501	Rotary Encoder 12P	2464	5322 126 11583	10nF 10% 50V
1616	2422 129 16835	Switch Jog-Shuttle	2566	4822 122 33761	22pF 5% 50V
1700	2422 025 14526	Flex Connector 16P	2567	4822 122 33761	22pF 5% 50V
1701	2422 025 14526	Flex Connector 16P	2568	4822 122 33761	22pF 5% 50V
			2569	4822 122 33761	22pF 5% 50V
			2570	4822 122 33761	22pF 5% 50V
			2571	4822 122 33761	22pF 5% 50V
			2572	4822 122 33761	22pF 5% 50V
			2573	4822 122 33761	22pF 5% 50V
			2574	4822 122 33761	22pF 5% 50V
			2575	4822 122 33761	22pF 5% 50V
			2576	4822 122 33761	22pF 5% 50V
			2577	4822 122 33761	22pF 5% 50V
			2578	4822 122 33761	22pF 5% 50V
			2604	5322 126 11583	10nF 10% 50V
			2605	4822 126 14494	22nF 10% 25V
			2606	4822 126 14494	22nF 10% 25V
			2607	4822 126 14494	22nF 10% 25V
			2608	2020 552 94427	100pF 5% 50V
			2800	2020 552 96305	4,7uF +80/-20% 10V
			2801	2238 586 59812	100nF 50V
			2900	4822 122 33741	10pF 10% 50V

CAPACITORS

2100	4822 126 14249	560pF 10% 50V	/22
2101	4822 122 33197	1nF 10% 50V	/22
2102	4822 126 14226	82pF 5% 50V	/22
2103	4822 126 11785	47pF 5% 50V	/22
2104	2238 586 59812	100nF 50V	/22
2105	4822 126 14249	560pF 10% 50V	/22
2106	4822 126 14491	2,2uF 10V	/22
2107	4822 122 33761	22pF 5% 50V	
2108	2020 552 94427	100pF 5% 50V	
2109	2020 552 94427	100pF 5% 50V	
2110	4822 122 33761	22pF 5% 50V	
2111	2020 552 94427	100pF 5% 50V	
2114	4822 122 33741	10pF 10% 50V	
2115	4822 122 33741	10pF 10% 50V	
2300	3198 017 41050	1uF 10V	
2301	3198 017 41050	1uF 10V	

ELECTRICAL PARTS LIST - FRONT BOARD

2901	4822 122 33741	10pF 10% 50V	3360	4822 051 30221	220R 5% 0,062W
2902	4822 122 33741	10pF 10% 50V	3400	4822 051 30102	1k 5% 0,062W
2903	4822 122 33741	10pF 10% 50V	3401	4822 050 11002	1k 1% 0,4W
			3402	4822 051 30102	1k 5% 0,062W
			3403	4822 051 30102	1k 5% 0,062W
			3404	4822 051 30102	1k 5% 0,062W
			3405	4822 051 30471	470R 5% 0,062W
			3406	4822 051 30102	1k 5% 0,062W
			3407	4822 051 30102	1k 5% 0,062W
			3408	4822 051 30102	1k 5% 0,062W
			3409	4822 051 30102	1k 5% 0,062W
			3410	4822 051 30102	1k 5% 0,062W
			3411	4822 051 30102	1k 5% 0,062W
			3412	4822 051 30102	1k 5% 0,062W
			3413	4822 051 30102	1k 5% 0,062W
			3414	4822 051 30102	1k 5% 0,062W
			3415	4822 051 30102	1k 5% 0,062W
			3416	4822 051 30102	1k 5% 0,062W
			3417	4822 051 30102	1k 5% 0,062W
			3418	4822 051 30102	1k 5% 0,062W
			3419	4822 051 30102	1k 5% 0,062W
			3420	4822 051 30102	1k 5% 0,062W
			3421	4822 051 30102	1k 5% 0,062W
			3422	4822 051 30102	1k 5% 0,062W
			3423	4822 051 30102	1k 5% 0,062W
			3424	4822 051 30102	1k 5% 0,062W
			3425	4822 051 30102	1k 5% 0,062W
			3426	4822 051 30102	1k 5% 0,062W
			3427	4822 051 30102	1k 5% 0,062W
			3428	4822 051 30102	1k 5% 0,062W
			3429	4822 051 30102	1k 5% 0,062W
			3430	4822 051 30102	1k 5% 0,062W
			3431	4822 051 30102	1k 5% 0,062W
			3432	4822 051 30102	1k 5% 0,062W
			3433	4822 051 30102	1k 5% 0,062W
			3434	4822 051 30102	1k 5% 0,062W
			3435	4822 051 30102	1k 5% 0,062W
			3436	4822 051 30102	1k 5% 0,062W
			3437	4822 051 30102	1k 5% 0,062W
			3438	4822 051 30102	1k 5% 0,062W
			3439	4822 051 30102	1k 5% 0,062W
			3440	4822 051 30102	1k 5% 0,062W
			3441	4822 051 30102	1k 5% 0,062W
			3442	4822 051 30102	1k 5% 0,062W
			3443	4822 051 30102	1k 5% 0,062W
			3444	4822 051 30102	1k 5% 0,062W
			3445	4822 051 30102	1k 5% 0,062W
			3446	4822 051 30102	1k 5% 0,062W
			3447	4822 051 30102	1k 5% 0,062W
			3448	4822 051 30103	10k 5% 0,062W
			3449	4822 051 30102	1k 5% 0,062W
			3450	4822 051 30102	1k 5% 0,062W

RESISTORS

3100	4822 051 30152	1k5 5% 0,062W	/22
3101	4822 051 30103	10k 5% 0,062W	/22
3102	4822 051 30222	2k2 5% 0,062W	/22
3103	4822 117 12891	220k 1%	/22
3104	4822 051 30102	1k 5% 0,062W	/22
3105	4822 051 30102	1k 5% 0,062W	/22
3106	4822 117 12925	47k 1% 0,063W	/21M/37
3107	4822 117 12925	47k 1% 0,063W	/21M/37
3108	4822 051 30102	1k 5% 0,062W	
3109	4822 051 30102	1k 5% 0,062W	
3110	4822 051 30471	470R 5% 0,062W	
3111	4822 051 30471	470R 5% 0,062W	
3112	4822 051 30102	1k 5% 0,062W	
3113	4822 051 30471	470R 5% 0,062W	
3114	4822 051 30103	10k 5% 0,062W	
3116	4822 051 30103	10k 5% 0,062W	
3117	4822 051 30101	100R 5% 0,062W	
3118	4822 051 30101	100R 5% 0,062W	
3119	4822 051 30101	100R 5% 0,062W	
3120	4822 051 30223	22k 5% 0,062W	
3121	4822 117 13632	100k 1% 0,62W	
3122	4822 051 30682	6k8 5% 0,062W	
3125	4822 051 30103	10k 5% 0,062W	
3126	4822 051 30221	220R 5% 0,062W	
3127	4822 051 30221	220R 5% 0,062W	
3128	4822 051 30103	10k 5% 0,062W	
3300	4822 117 12971	15R 5% 0,62W	
3301	4822 117 12971	15R 5% 0,62W	
3302	4822 117 12971	15R 5% 0,62W	
3303	4822 117 12971	15R 5% 0,62W	
3304	4822 051 30472	4k7 5% 0,062W	
3305	4822 051 30103	10k 5% 0,062W	
3306	4822 051 30102	1k 5% 0,062W	
3307	4822 051 30472	4k7 5% 0,062W	
3308	4822 051 30103	10k 5% 0,062W	
3309	4822 051 30102	1k 5% 0,062W	
3310	4822 051 30109	10R 5% 0,062W	
3311	4822 051 30109	10R 5% 0,062W	
3312	4822 051 30109	10R 5% 0,062W	
3313	4822 051 30109	10R 5% 0,062W	
3314	4822 051 30109	10R 5% 0,062W	
3349	4822 051 30103	10k 5% 0,062W	
3350	4822 117 12925	47k 1% 0,063W	
3351	4822 051 30103	10k 5% 0,062W	
3357	4822 051 30684	680k 5% 0,062W	
3358	4822 117 12917	1R 5% 0,062W	
3359	4822 051 30221	220R 5% 0,062W	

ELECTRICAL PARTS LIST - FRONT BOARD**RESISTORS**

3451	4822 051 30102	1k 5% 0,062W	3536	4822 051 30103	10k 5% 0,062W
3452	4822 051 30102	1k 5% 0,062W	3537	4822 051 30681	680R 5% 0,062W
3453	4822 051 30102	1k 5% 0,062W	3538	4822 051 30472	4k7 5% 0,062W
3454	4822 051 30102	1k 5% 0,062W	3539	4822 051 30103	10k 5% 0,062W
3455	4822 051 30102	1k 5% 0,062W	3540	4822 051 30681	680R 5% 0,062W
3456	4822 051 30102	1k 5% 0,062W	3541	4822 051 30472	4k7 5% 0,062W
3457	4822 051 30102	1k 5% 0,062W	3542	4822 051 30103	10k 5% 0,062W
3458	4822 051 30102	1k 5% 0,062W	3543	4822 051 30681	680R 5% 0,062W
3459	4822 051 30102	1k 5% 0,062W	3544	4822 051 30472	4k7 5% 0,062W
3460	4822 051 30102	1k 5% 0,062W	3545	4822 051 30103	10k 5% 0,062W
3461	4822 051 30102	1k 5% 0,062W	3546	4822 051 30681	680R 5% 0,062W
3462	4822 051 30102	1k 5% 0,062W	3547	4822 051 30472	4k7 5% 0,062W
3463	4822 051 30102	1k 5% 0,062W	3548	4822 051 30103	10k 5% 0,062W
3464	4822 051 30102	1k 5% 0,062W	3549	4822 051 30681	680R 5% 0,062W
3465	4822 051 30102	1k 5% 0,062W	3566	4822 051 30682	6k8 5% 0,062W
3466	4822 051 30102	1k 5% 0,062W	3567	4822 051 30682	6k8 5% 0,062W
3467	4822 051 30102	1k 5% 0,062W	3569	4822 051 30682	6k8 5% 0,062W
3468	4822 051 30102	1k 5% 0,062W	3570	4822 051 30682	6k8 5% 0,062W
3469	4822 051 30102	1k 5% 0,062W	3571	4822 051 30682	6k8 5% 0,062W
3470	4822 051 30102	1k 5% 0,062W	3572	4822 051 30682	6k8 5% 0,062W
3471	4822 051 30221	220R 5% 0,062W	3573	4822 051 30682	6k8 5% 0,062W
3472	4822 051 30221	220R 5% 0,062W	3574	4822 051 30682	6k8 5% 0,062W
3475	4822 051 30103	10k 5% 0,062W	3575	4822 051 30682	6k8 5% 0,062W
3476	4822 051 30272	2k7 5% 0,062W	3576	4822 051 30682	6k8 5% 0,062W
3477	4822 051 30272	2k7 5% 0,062W	3577	4822 051 30682	6k8 5% 0,062W
3484	4822 117 13632	100k 1% 0,62W	3578	4822 051 30682	6k8 5% 0,062W
3485	4822 051 30102	1k 5% 0,062W	3579	4822 051 30103	10k 5% 0,062W
3487	4822 051 30684	680k 5% 0,062W	3580	4822 051 30103	10k 5% 0,062W
3491	4822 051 30471	470R 5% 0,062W	3581	4822 051 30103	10k 5% 0,062W
3492	4822 051 30471	470R 5% 0,062W	3582	4822 051 30103	10k 5% 0,062W
3493	4822 051 30682	6k8 5% 0,062W	3584	4822 051 30103	10k 5% 0,062W
3494	4822 051 30682	6k8 5% 0,062W	3585	4822 051 30101	100R 5% 0,062W
3495	4822 117 12925	47k 1% 0,063W	3586	4822 051 30103	10k 5% 0,062W
3496	4822 117 12925	47k 1% 0,063W	3587	4822 051 30102	1k 5% 0,062W
3497	4822 051 30681	680R 5% 0,062W	3600	4822 051 30151	150R 5% 0,062W
3499	4822 051 30103	10k 5% 0,062W	3601	4822 051 30221	220R 5% 0,062W
3502	4822 051 30472	4k7 5% 0,062W	3602	4822 051 30151	150R 5% 0,062W
3503	4822 051 30272	2k7 5% 0,062W	3603	4822 051 30472	4k7 5% 0,062W
3504	4822 117 12903	1k8 1% 0,063W	3604	4822 051 30103	10k 5% 0,062W
3505	4822 117 11817	1k2 1% 1/16W	3605	4822 051 30102	1k 5% 0,062W
3506	4822 117 12968	820R 5% 0,62W	3606	4822 051 30472	4k7 5% 0,062W
3507	4822 051 30561	560R 5% 0,062W	3607	4822 051 30103	10k 5% 0,062W
3508	4822 051 30391	390R 5% 0,062W	3608	4822 051 30103	10k 5% 0,062W
3509	4822 051 30271	270R 5% 0,062W	3609	4822 051 30103	10k 5% 0,062W
3510	4822 051 30221	220R 5% 0,062W	3900	4822 051 30102	1k 5% 0,062W
3511	4822 051 30151	150R 5% 0,062W	3901	4822 051 30102	1k 5% 0,062W
3516	4822 051 30271	270R 5% 0,062W	3902	4822 051 30102	1k 5% 0,062W
3517	4822 051 30391	390R 5% 0,062W	3903	4822 051 30102	1k 5% 0,062W
3518	4822 051 30561	560R 5% 0,062W	3904	4822 051 30102	1k 5% 0,062W
3519	4822 117 12968	820R 5% 0,62W	3905	4822 051 30102	1k 5% 0,062W
3520	4822 117 11817	1k2 1% 1/16W	3906	4822 051 30102	1k 5% 0,062W
3535	4822 051 30472	4k7 5% 0,062W	3907	4822 051 30102	1k 5% 0,062W

ELECTRICAL PARTS LIST - FRONT BOARD

3908	4822 051 30102	1k 5% 0,062W
3909	4822 051 30221	220R 5% 0,062W
3910	4822 051 30221	220R 5% 0,062W
3911	4822 051 30221	220R 5% 0,062W
3912	4822 051 30221	220R 5% 0,062W
3915	4822 051 30105	1M 5% 0,062W
3916	4822 051 30105	1M 5% 0,062W
3920	4822 051 30562	5k6 5% 0,063W
3921	4822 051 30562	5k6 5% 0,063W
4401	4822 051 30008	0R Jumper 0603
4403	4822 051 30008	0R Jumper 0603
4404	4822 051 30008	0R Jumper 0603
4407	4822 051 30008	0R Jumper 0603
4408	4822 051 30008	0R Jumper 0603
4409	4822 051 30008	0R Jumper 0603
4411	4822 051 30008	0R Jumper 0603
4413	4822 051 30008	0R Jumper 0603
4414	4822 051 30008	0R Jumper 0603
4415	4822 051 30008	0R Jumper 0603
4416	4822 051 30008	0R Jumper 0603
4417	4822 051 30008	0R Jumper 0603
4418	4822 051 30008	0R Jumper 0603
4419	4822 051 30008	0R Jumper 0603
4420	4822 051 30008	0R Jumper 0603
4422	4822 051 30008	0R Jumper 0603
4423	4822 051 30008	0R Jumper 0603
4425	4822 051 30008	0R Jumper 0603
4432	4822 051 30008	0R Jumper 0603
4433	4822 051 30008	0R Jumper 0603
4441	4822 051 30008	0R Jumper 0603
4442	4822 051 30008	0R Jumper 0603
4443	4822 051 30008	0R Jumper 0603
4445	4822 051 30008	0R Jumper 0603
4451	4822 051 30008	0R Jumper 0603
4452	4822 051 30008	0R Jumper 0603
4453	4822 051 30008	0R Jumper 0603
4701	4822 051 20008	0R Jumper 0805
4702	4822 051 20008	0R Jumper 0805

COILS & FILTERS

5400	5322 242 73686	RES CER 12MHz
5401	2422 543 01069	RES XTL 32,768kHz
5402	4822 242 11033	RES XTL 4,332MHz /22
5443	4822 157 10586	Coil 2,2uH 10%
5444	4822 157 10586	Coil 2,2uH 10%
5445	4822 157 10586	Coil 2,2uH 10%
5446	4822 157 10586	Coil 2,2uH 10%
5448	4822 157 62552	Coil 2,2uH 5%
5450	4822 157 10586	Coil 2,2uH 10% /22
5451	4822 157 10586	Coil 2,2uH 10%
5600	4822 157 10586	Coil 2,2uH 10%
5601	4822 157 10586	Coil 2,2uH 10%

5602 4822 157 10586 Coil 2,2uH 10%

DIODES

6400	4822 130 30621	1N4148
6401	9322 193 08676	LED VS LTL816VYK
6402	9322 193 08676	LED VS LTL816VYK
6403	9322 193 08676	LED VS LTL816VYK
6404	9322 193 08676	LED VS LTL816VYK
6405	9322 193 08676	LED VS LTL816VYK
6415	4822 130 31878	1N4003G
6416	4822 130 31878	1N4003G
6460	9322 155 82667	IR Receiver TSOP2236ZC1
6500	9322 193 08676	LED VS LTL816VYK
6501	9322 193 08676	LED VS LTL816VYK
6502	9322 193 08676	LED VS LTL816VYK
6503	9322 193 08676	LED VS LTL816VYK
6504	9322 193 08676	LED VS LTL816VYK
6505	9322 193 08676	LED VS LTL816VYK
6506	9322 193 08676	LED VS LTL816VYK
6507	9322 193 08676	LED VS LTL816VYK
6508	9322 193 08676	LED VS LTL816VYK
6509	9322 193 08676	LED VS LTL816VYK
6600	9322 179 76676	LED VS LTL-816EELC
6605	9965 000 05596	LED VS LTL-42UB6N

TRANSISTORS & INTEGRATED CIRCUITS

7300	5322 130 60159	BC847B
7301	4822 130 60373	BC857B
7302	5322 130 60159	BC847B
7303	4822 130 60373	BC857B
7401	5322 130 60159	BC847B
7402	5322 130 60159	BC847B
7403	5322 130 60159	BC847B
7404	5322 130 60159	BC847B
7405	5322 130 60159	BC847B
7426	5322 130 60159	BC847B
7427	5322 130 60159	BC847B
7428	4822 209 17226	M24C08-WMN6
7429	5322 130 60159	BC847B
7430	9352 686 05118	SAA6581T /22
7431	3139 110 53441	TMP88CU77F - 'i25053441'
7600	5322 130 60159	BC847B
7601	5322 130 60159	BC847B

Note : Only the parts mentioned in this list are normal service spare parts.

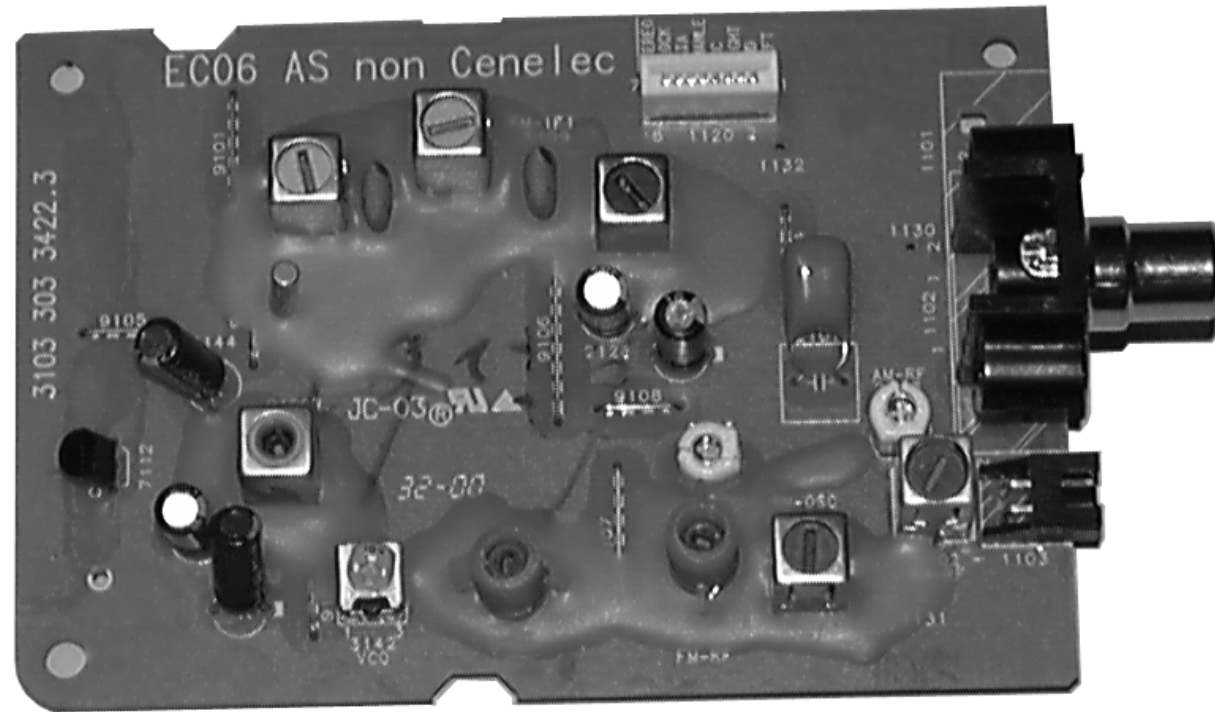

BLOCK DIAGRAM

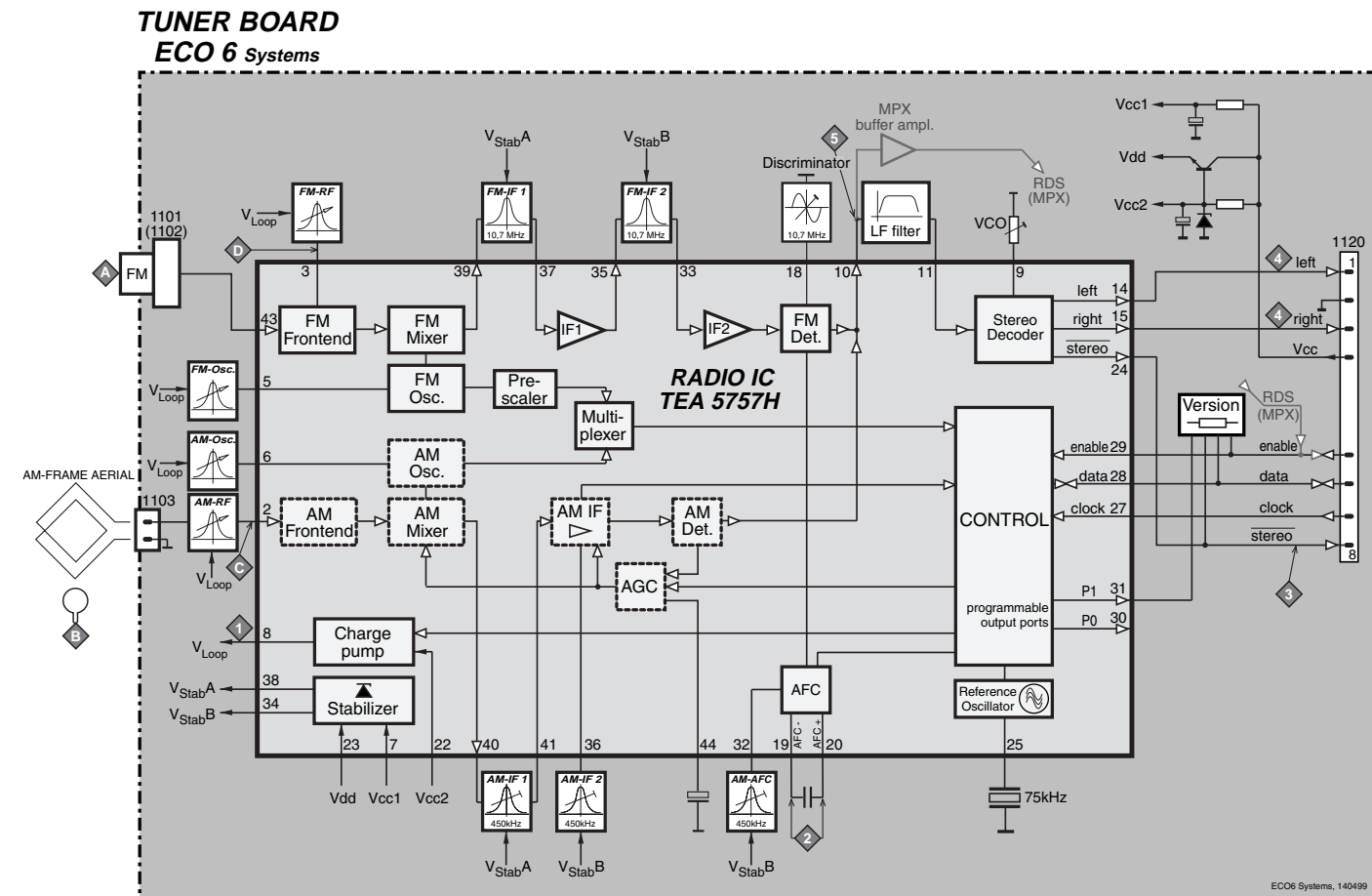

ECO6 Tuner Board
version: **SYSTEMS non-CENELEC**

TABLE OF CONTENTS

Blockdiagram7A-1
 Schematic Diagram7A-2
 Component Layout.....7A-3
 Adjustment table7A-3
 Electrical Partslist.....7A-4

TUNER BOARD ECO6 / SYSTEMS NON CENELEC

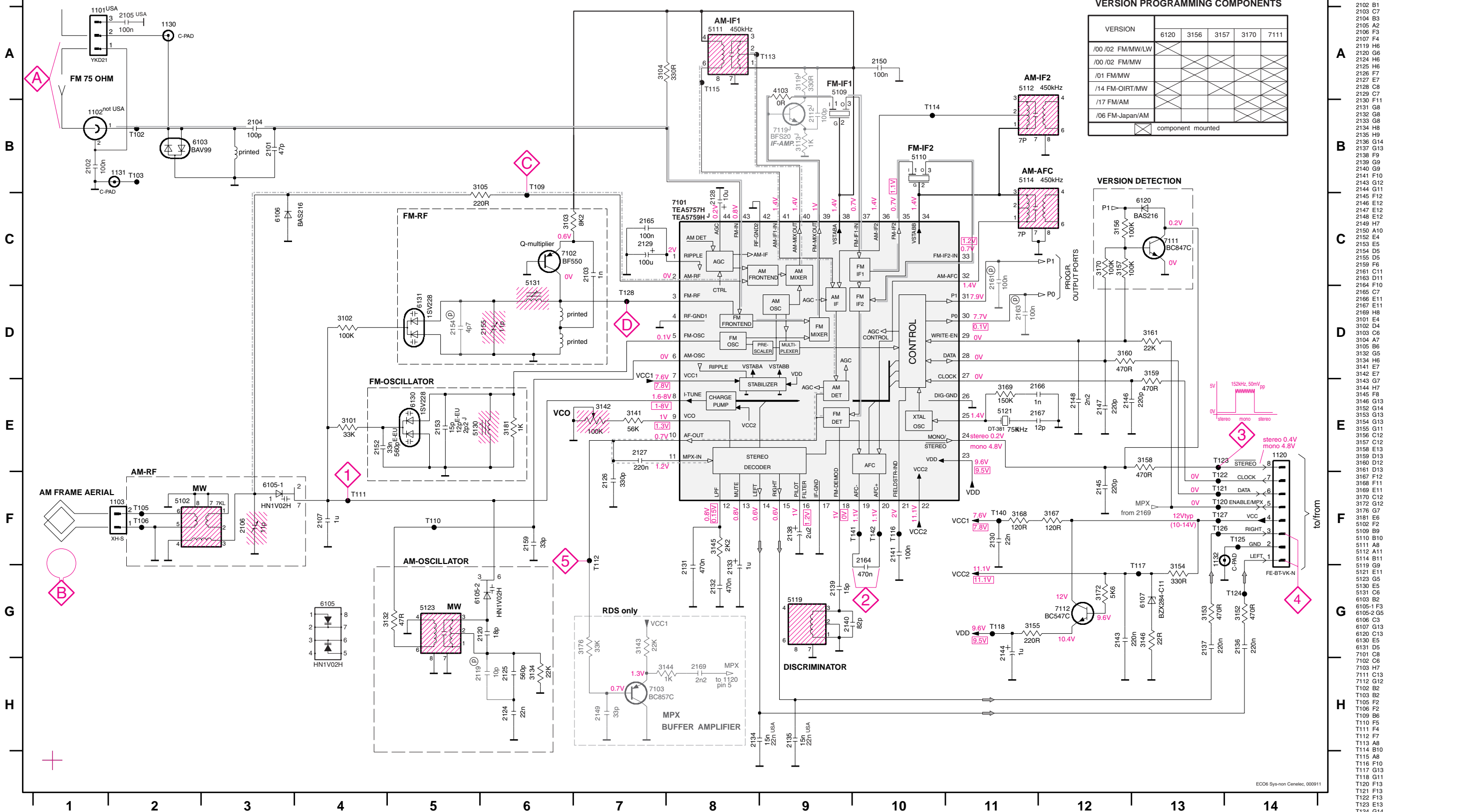

VERSION PROGRAMMING COMPONENTS

VERSION	6120	3156	3157	3170	7111
/00 /02 FM/MW/LW					
/00 /02 FM/MW					
/01 FM/MW					
/14 FM-OIRT/MW					
/17 FM/AM					
/06 FM-Japan/AM					

component mounted

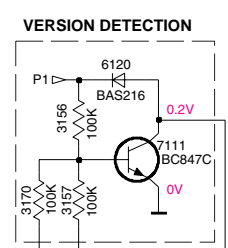

- 1101 A1
- 1102 B1
- 1103 F2
- 1120 E14
- 1130 A2
- 1131 B2
- 1132 G13
- 1131 B3
- 2102 B1
- 2103 C7
- 2104 B3
- 2105 A2
- 2106 F3
- 2107 F4
- 2119 H6
- 2120 G6
- 2124 H6
- 2125 H6
- 2126 F7
- 2127 E7
- 2128 C8
- 2129 C7
- 2130 F11
- 2131 G8
- 2132 G8
- 2133 G8
- 2134 H8
- 2135 H9
- 2136 G14
- 2137 G13
- 2138 F9
- 2139 G9
- 2140 G9
- 2141 F10
- 2143 G12
- 2144 G11
- 2145 F12
- 2146 E12
- 2147 E12
- 2148 H7
- 2149 H7
- 2150 A10
- 2152 E4
- 2153 E5
- 2154 D5
- 2155 D5
- 2159 F6
- 2161 C11
- 2163 D11
- 2164 F10
- 2165 C7
- 2166 E11
- 2167 E11
- 2169 H8
- 3101 E4
- 3102 D4
- 3103 C6
- 3104 A7
- 3105 B6
- 3132 G5
- 3134 H6
- 3141 E7
- 3142 E7
- 3143 G7
- 3144 H7
- 3145 F8
- 3146 G13
- 3152 G14
- 3153 G13
- 3154 G13
- 3155 G11
- 3156 C12
- 3157 D12
- 3158 E13
- 3159 D13
- 3160 D13
- 3161 D13
- 3167 F12
- 3168 F11
- 3169 E11
- 3170 C12
- 3172 G12
- 3176 G7
- 3181 E6
- 5102 F2
- 5109 B9
- 5110 B10
- 5111 A8
- 5112 A11
- 5114 B11
- 5119 G9
- 5121 E11
- 5123 G5
- 5130 E5
- 5131 C6
- 5132 B2
- 6105-1 F3
- 6105-2 G5
- 6106 C3
- 6107 G13
- 6120 G13
- 6130 E5
- 6131 D5
- 7101 C8
- 7102 C6
- 7103 H7
- 7111 C13
- 7112 F13
- T102 B2
- T103 B2
- T105 F2
- T106 F2
- T109 B6
- T110 F5
- T111 F4
- T112 F7
- T113 A8
- T114 B10
- T115 A8
- T117 G10
- T118 G13
- T121 F13
- T122 F13
- T123 E13
- T124 G14
- T125 F14
- T126 F13
- T127 F13
- T128 D7
- T140 F11
- T141 F10
- T142 F10

LEGEND

- Ⓟ...for provision only
- USA ... for USA version only
- E-EU ... for East European version only
- J ... for Japanese version only

- Ⓜ...V FM mode stereo
- Ⓜ...V MW mode
- Ⓜ...V LW mode
- Ⓜ...V EVM
- voltages measured while set is tuned to a strong transmitter

- Signal path**
- FM
 - - - AM
 - · - · MPX (Audio Frequency)
 - ⇒ AF - left/right

1101 A6 1120 A4 1132 A5 2128 C4 2138 C2 3142 D2 5110 B3 5114 A2 5123 D5 7112 C1 9104 B5 9107 D4
 1102 B6 1130 B5 2106 C5 2129 B4 2144 B2 5102 D6 5111 B4 5119 C2 5130 D3 9101 A2 9105 B1 9108 C4
 1103 D6 1131 D5 2107 B5 2133 D2 2155 C4 5109 A3 5112 A3 5121 B2 5131 D4 9103 B2 9106 B3 9109 D2

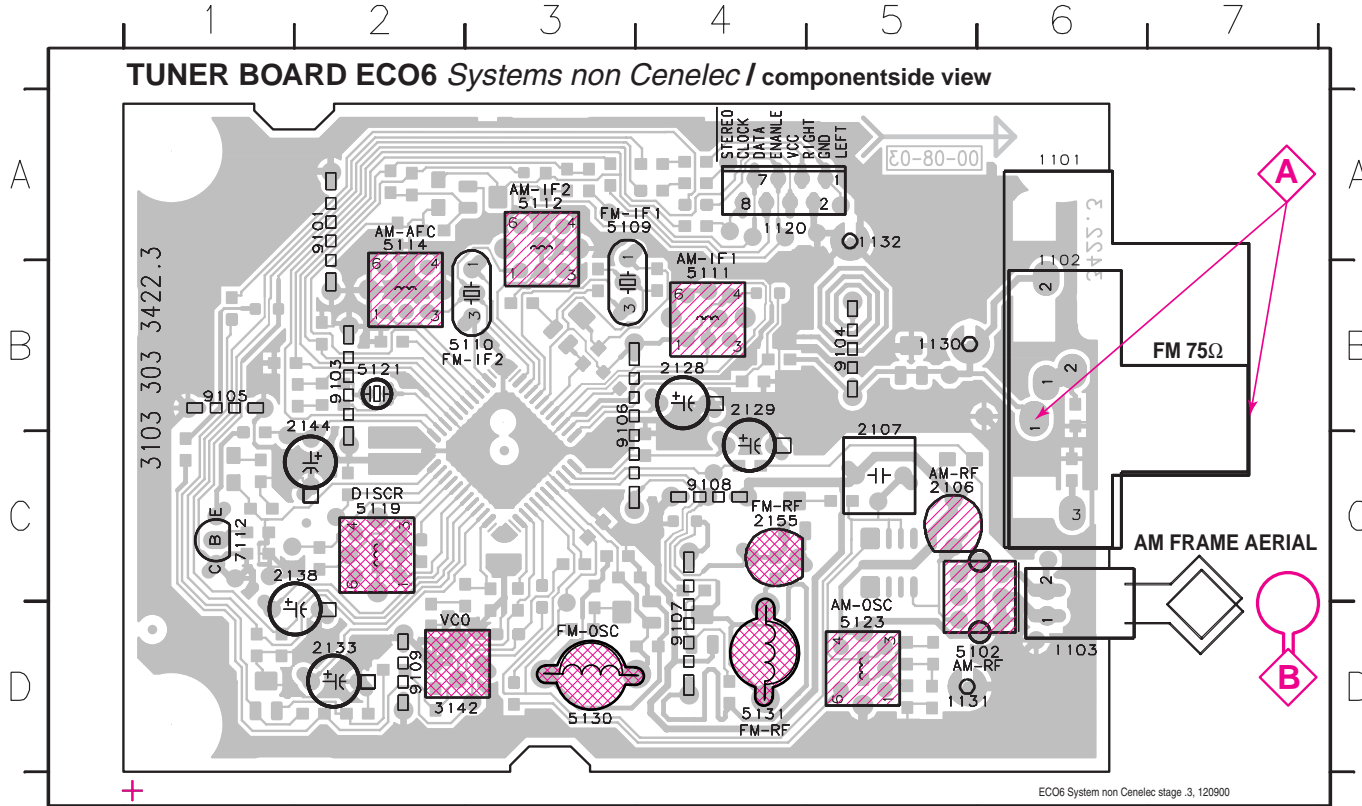

2101 B4 2119 D3 2130 D5 2137 A4 2146 B7 2153 C5 2165 C4 3103 C4 3134 D3 3152 A4 3158 A4 3169 B6 4106 C4 6107 C7 7103 D7
 2102 B1 2120 D3 2131 C5 2139 C6 2147 A5 2154 C4 2166 B6 3104 B4 3141 C5 3153 A4 3159 A5 3170 A6 4107 C5 6120 A6 7111 A5
 2103 D4 2124 D3 2132 D6 2140 C6 2148 B6 2159 C5 2167 B6 3105 C4 3143 D6 3154 C7 3160 A5 3172 C7 4108 C5 6130 D4 7119 B5
 2104 B4 2125 D3 2134 D7 2141 C6 2149 D6 2161 A6 2169 A4 3113 B5 3144 B7 3155 C7 3161 A5 3176 D6 6103 B3 6131 C4
 2105 C1 2126 D6 2135 D7 2143 C7 2150 B5 2163 B6 3101 D5 3119 B5 3145 C5 3156 A6 3167 B7 3181 D4 6105 C3 7101 C5
 2112 B5 2127 C5 2136 A4 2145 A5 2152 C5 3102 C3 3132 D5 3146 C7 3157 A6 3168 C7 4103 B5 6106 C3 7102 D4

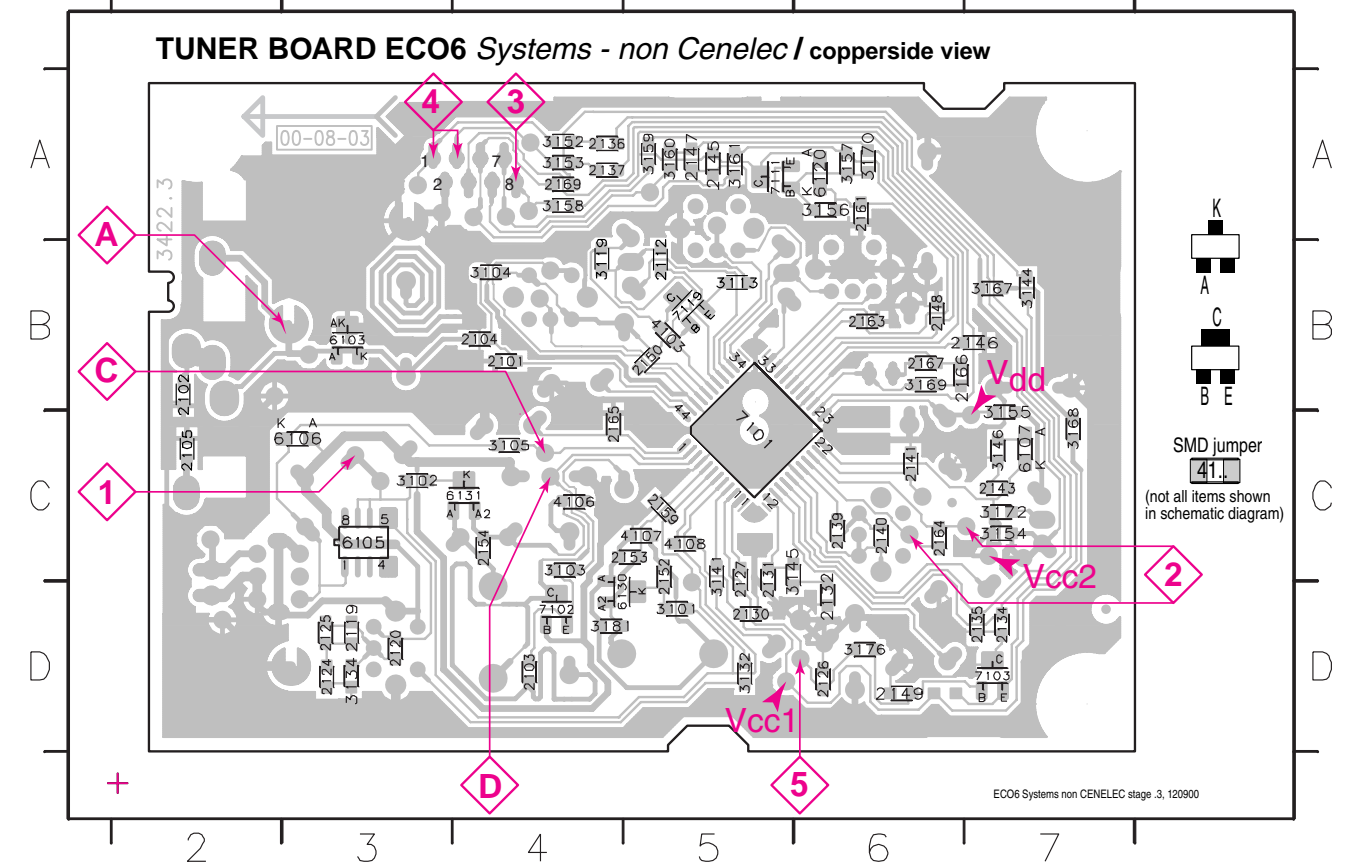

These assembly drawings show a summary of all possible versions.
 For components used in a specific version see schematic diagram respectively partlist.

TUNER ADJUSTMENT TABLE (ECO6 FM/MW- and FM/MW/LW - versions with AM-frame aerial)

Waverange	Input frequency	Input	Tuned to	Adjust	Output	Scope/Voltmeter
VARICAP ALIGNMENT						
FM 87.5 - 108MHz (65.81 - 74, 87.5 - 108MHz)			108MHz	5130		8V ±0.2V
			87.5MHz (65.81MHz)	check		4.3V ±0.5V (1.2V ±0.5V)
MW FM/AM-version, 10kHz grid 530 - 1700kHz			1700kHz	5123		8V ±0.2V
			530kHz	check		1.1V ±0.4V
FM/MW-version, 9kHz grid 531 - 1602kHz			1602kHz	5123	1	6.9V ±0.2V
			531kHz	check		1.1V ±0.4V
LW 153 - 279kHz			279kHz	5122		8V ±0.2V
			153kHz	check		1.1V ±0.4V
MW FM/MW/LW- version, 9kHz grid 531 - 1602kHz			1602kHz	5123		8V ±0.2V
			531kHz	check		1.1V ±0.4V
FM IF						
FM	10.7MHz, 45mV continuous wave	D		5119	2	0 ± 3 mV DC
FM RF						
FM 87.5 - 108MHz (65.81 - 74, 87.5 - 108MHz)	108MHz	A	108MHz	2155	4	MAX
	87.5MHz (65.81MHz)	mod=1kHz Δf=±22.5kHz	87.5MHz (65.81MHz)	5131		
VCO						
FM	98MHz, 1mV continuous wave	A	98MHz	3142	3	152kHz ±1kHz ¹⁾
AM IF						
MW	450kHz connect pin 6 of IC 7101 (AM Osc.) with 3.3kΩ to Vcc	C		5111	5	
		C		5112		
AM AFC MW		C		5114	2	0 ± 2 mV DC
AM RF³⁾						
MW⁴⁾ FM/MW/LW- and FM/MW-version (9kHz grid)	1494kHz	B	1494kHz	2106	5	
	531 - 1602kHz		558kHz	5102		
LW	198kHz		198kHz	5103		
MW FM/AM-version, 10kHz grid 530 - 1700kHz	1500kHz	B	1500kHz	2106	5	
	560kHz		560kHz	5102		

Use Service Testprogram. By selecting the TUNER TEST test frequencies will be stored as preset frequencies automatically.

- 1) If sensitivity of frequency counter is too low adjust to max. channel separation (input signal: stereo left 90% + 9%, adjust output on right channel to minimum)
- 2) RC network serves for damping the IF-filter while adjusting the other one.
- 3) For AM RF adjustments the original frame antenna has to be used!
- 4) MW has to be aligned before LW.

↑ Repeat

MISCELLANEOUS

1101	2422 015 19376	SOCKET 2P CLICKFIT	USA only
1102	4822 267 10283	SOCKET COAX, IEC 75Ω	not USA
1103	4822 265 31184	JST CONNECTOR 2 POLE	
1120	4822 265 11515	FFC SOCKET, 8P	

CAPACITORS

2101	4822 126 13692	47pF	1%	63V	
2102	4822 126 13838	100nF	10%	50V	not USA
2103	5322 122 31647	1nF	10%	63V	
2104	5322 122 32531	100pF	5%	50V	
2105	4822 126 13838	100nF	10%	50V	USA only
2106	2020 800 00191	3-11pF TRIMCAP.,N450			
2107	4822 121 51319	1μF	20%	50V	
2120	4822 126 13689	18pF	1%	63V	
2124	5322 122 32654	22nF	10%	63V	
2125	2020 552 96199	560pF	1%	50V	
2126	5322 122 31863	330pF	5%	50V	
2127	4822 126 14076	220nF	20%	25V	
2128	4822 124 40248	10μF	20%	63V	
2129	4822 124 41584	100μF	20%	10V	
2130	5322 122 32654	22nF	10%	63V	
2131	4822 126 13482	470nF	20%	16V	
2132	4822 126 13482	470nF	20%	16V	
2133	4822 124 21913	1μF	20%	63V	
2134	4822 126 13188	15nF	5%	63V	not USA
2134	5322 122 32654	22nF	10%	63V	USA only
2135	4822 126 13188	15nF	5%	63V	not USA
2135	5322 122 32654	22nF	10%	63V	USA only
2136	4822 126 14076	220nF	20%	25V	
2137	4822 126 14076	220nF	20%	25V	
2138	4822 124 22652	2,2μF	20%	50V	
2139	4822 126 14236	15pF	5%	50V	
2140	4822 126 13695	82pF	1%	63V	
2141	4822 126 13838	100nF	10%	50V	
2143	4822 126 14076	220nF	20%	25V	
2144	4822 124 21913	1μF	20%	63V	
2145	4822 122 33575	220pF	5%	50V	
2146	4822 122 33575	220pF	5%	50V	
2147	4822 122 33575	220pF	5%	50V	
2148	4822 122 33127	2,2nF	10%	63V	
2149	5322 122 32659	33pF	5%	50V	RDS only
2150	4822 126 13838	100nF	10%	50V	
2152	4822 126 12105	33nF	5%	63V	not for East Europe
2152	5322 116 80853	560pF	5%	63V	for East Europe only
2153	4822 126 13486	15pF	2%	63V	not for East Europe
2153	4822 122 33926	12pF	2%	50V	for East Europe only
2155	2020 800 00191	3-11pF TRIMCAP.,N450			
2159	5322 122 32659	33pF	5%	50V	
2164	4822 126 13482	470nF	20%	16V	
2165	4822 126 13838	100nF	10%	50V	
2166	5322 122 31647	1nF	10%	63V	
2167	4822 122 33926	12pF	5%	50V	
2169	4822 122 33127	2,2nF	10%	63V	RDS only

RESISTORS

3101	4822 051 20333	33kΩ	5%	0,1W
3102	4822 117 10837	100kΩ	1%	0,1W
3103	4822 051 20822	8,2kΩ	5%	0,1W
3104	4822 117 13577	330Ω	1%	0,1W
3105	4822 117 11503	220Ω	5%	0,1W
3132	4822 051 20479	47Ω	5%	0,1W
3134	4822 051 20223	22kΩ	5%	0,1W
3141	4822 117 11148	56kΩ	1%	0,1W
3142	4822 100 12159	TRIMPOT. 100kΩ		

RESISTORS

3143	4822 051 20223	22kΩ	5%	0,1W	RDS only
3144	4822 051 10102	1kΩ	2%	0,25W	RDS only
3145	4822 117 11449	2,2kΩ	1%	0,1W	
3146	4822 051 20229	22Ω	5%	0,1W	
3152	4822 051 20471	470Ω	5%	0,1W	
3153	4822 051 20471	470Ω	5%	0,1W	
3154	4822 117 13577	330Ω	1%	0,1W	
3155	4822 117 11503	220Ω	5%	0,1W	
3156	4822 117 10837	100kΩ	1%	0,1W	
3157	4822 117 10837	100kΩ	1%	0,1W	
3158	4822 051 20471	470Ω	5%	0,1W	
3159	4822 051 20471	470Ω	5%	0,1W	
3160	4822 051 20471	470Ω	5%	0,1W	
3161	4822 051 20223	22kΩ	5%	0,1W	
3167	4822 051 20121	120Ω	5%	0,1W	
3168	4822 051 20121	120Ω	5%	0,1W	
3169	4822 051 20154	150kΩ	5%	0,1W	
3170	4822 117 10837	100kΩ	1%	0,1W	
3172	4822 051 20562	5,6kΩ	5%	0,1W	
3176	4822 051 20333	33kΩ	5%	0,1W	RDS only
3181	4822 051 10102	1kΩ	2%	0,25W	
4103	4822 051 20008	CHIP JUMPER 0805			
4106	4822 051 20008	CHIP JUMPER 0805			
4107	4822 051 20008	CHIP JUMPER 0805			
4108	4822 051 20008	CHIP JUMPER 0805			

COILS

5102	4822 157 71634	RF-COIL MW
5109	4822 242 70665	FM-IF FILTER 10,7MHz
5110	4822 242 70665	FM-IF FILTER 10,7MHz
5111	2422 549 44023	AM-IF FILTER 450kHz
5112	4822 157 70302	AM-IF FILTER 450kHz
5114	4822 157 70302	AM-IF FILTER 450kHz
5119	4822 157 11443	DISCRIMINATOR COIL
5121	4822 242 10261	QUARTZ 75kHz
5123	2422 549 44108	RF-COIL, AM-OSCILLATOR
5130	4822 157 11843	RF COIL 1,5 TURNS
5131	4822 157 11843	RF COIL 1,5 TURNS

DIODES

6103	5322 130 34337	BAV99
6105	4822 130 83075	HN1V02H
6106	4822 130 83757	BAS216
6107	9340 386 90115	BZX284-C11
6120	4822 130 83757	BAS216
6130	4822 130 82833	1SV228
6131	4822 130 82833	1SV228

TRANSISTORS

7102	4822 130 42131	BF550
7103	5322 130 42756	BC857C
7111	5322 130 42755	BC847C
7112	4822 130 44503	BC547C

INTEGRATED CIRCUITS

7101	9351 740 80557	TEA5757H/V1, RADIO IC
------	----------------	-----------------------

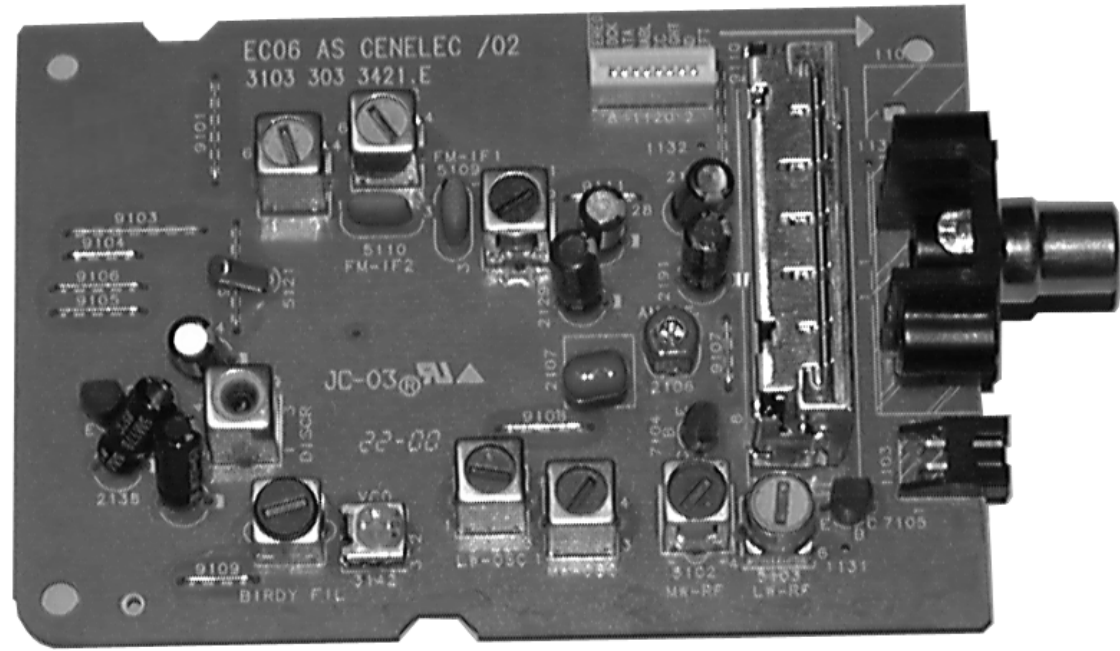

ECO6 Tuner Board

version: **SYSTEMS CENELEC**

TABLE OF CONTENTS

- Blockdiagram7B-1
- Schematic Diagram7B-2
- Component Layout7B-3
- Adjustment table7B-3
- Electrical Partslist7B-4

BLOCK DIAGRAM

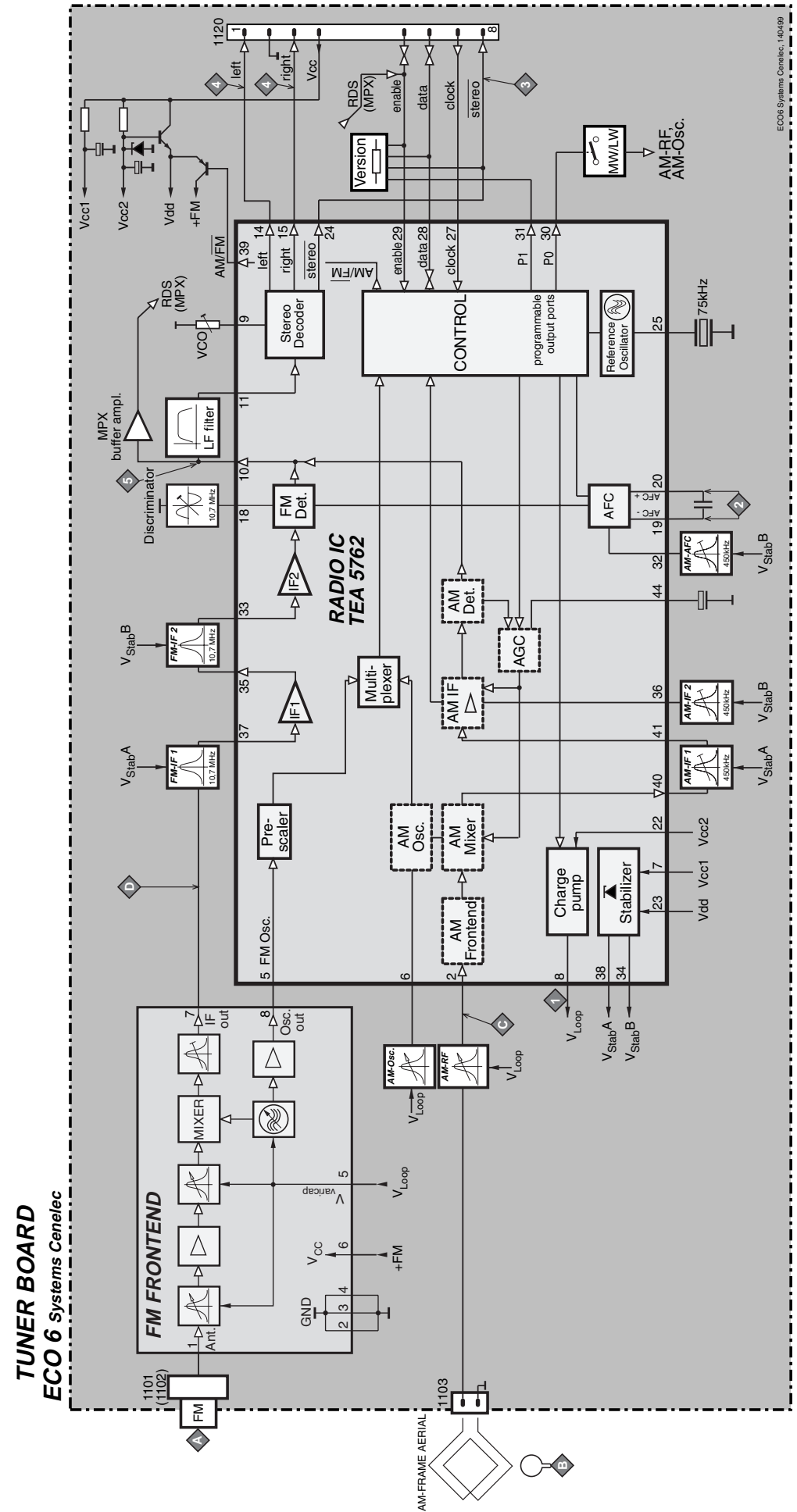

TUNER BOARD ECO6 / SYSTEMS-CENELEC

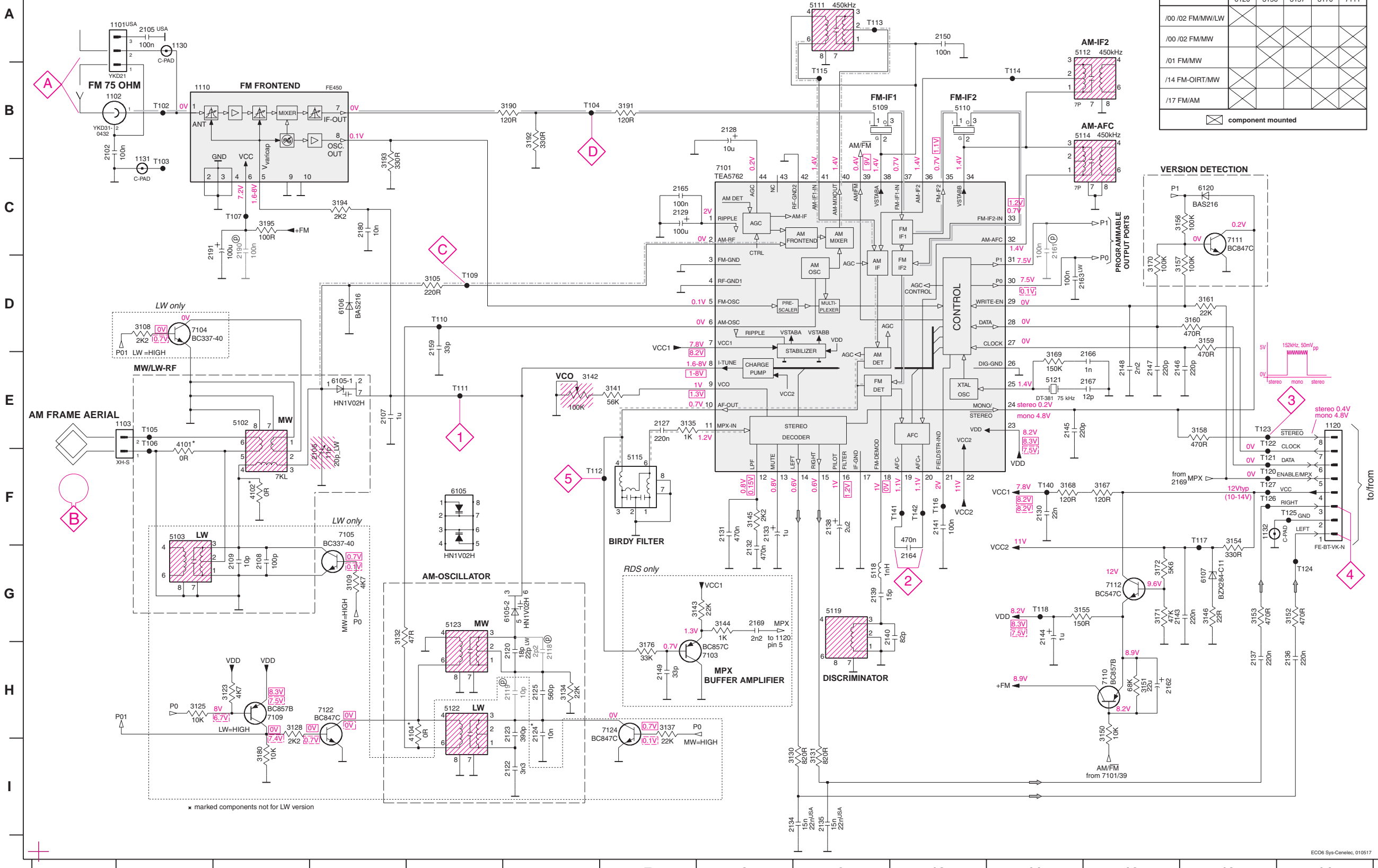

VERSION PROGRAMMING COMPONENTS

VERSION	6120	3156	3157	3170	7111
/00 /02 FM/MW/LW					
/00 /02 FM/MW					
/01 FM/MW					
/14 FM-OIRT/MW					
/17 FM/AM					

☒ component mounted

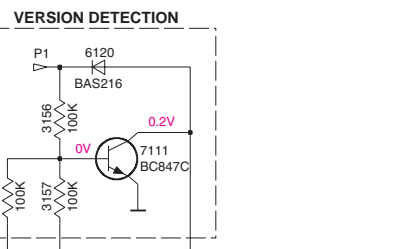

- 1101 A2
- 1102 B1
- 1103 E2
- 1110 B2
- 1120 E14
- 1130 A2
- 1131 C2
- 1132 F13
- 2102 B1
- 2105 A2
- 2106 E3
- 2107 E4
- 2108 G3
- 2109 G3
- 2118 H6
- 2119 H6
- 2120 H6
- 2122 I6
- 2123 H6
- 2124 H6
- 2125 H6
- 2127 E7
- 2128 B8
- 2129 C7
- 2130 F11
- 2131 F8
- 2132 F8
- 2133 F8
- 2134 I8
- 2135 I9
- 2136 H14
- 2137 H13
- 2138 F9
- 2139 G9
- 2140 G9
- 2141 F10
- 2143 G12
- 2144 G11
- 2145 E11
- 2146 E12
- 2147 E12
- 2148 E12
- 2149 H7
- 2150 A10
- 2159 D5
- 2161 C11
- 2162 H12
- 2163 D11
- 2164 G10
- 2165 C7
- 2166 E11
- 2167 E11
- 2169 G8
- 2180 C4
- 2190 C3
- 2191 C3
- 3105 D5
- 3108 D2
- 3109 S4
- 3123 H3
- 3128 H3
- 3130 I9
- 3131 I9
- 3132 G4
- 3134 H6
- 3135 E7
- 3137 H7
- 3141 E7
- 3142 E6
- 3143 G7
- 3144 G8
- 3145 F8
- 3146 G13
- 3150 H12
- 3151 H12
- 3152 G14
- 3153 G13
- 3154 F13
- 3155 G12
- 3156 C12
- 3157 D12
- 3158 E13
- 3159 D13
- 3160 D13
- 3161 D13
- 3167 F12
- 3168 F11
- 3169 E11
- 3170 D12
- 3171 G12
- 3172 G12
- 3176 H7
- 3180 I3
- 3190 B6
- 3191 B7
- 3192 B6
- 3193 B4
- 3194 C4
- 3195 C3
- 4101 E2
- 4102 F3
- 4104 H5
- 5102 E3
- 5103 F2
- 5109 B9
- 5110 B10
- 5111 A9
- 5112 A11
- 5114 B11
- 5115 E7
- 5118 G9
- 5119 G9
- 5121 E11
- 5122 H5
- 5123 G5
- 6105-1 E4
- 6105-2 G6
- 6106 D4
- 6107 G13
- 6120 C13
- 7101 C8
- 7103 H8
- 7104 D2
- 7105 F4
- 7109 H3
- 7110 H12
- 7111 C13
- 7112 G12
- 7112 H12
- 7114 B11
- 7116 F10
- 7117 F13
- 7118 G11
- 7120 F13
- 7121 F13
- 7122 E13
- 7123 E13
- 7124 G14
- 7125 F14
- 7126 F13
- 7127 F13
- 7140 F11
- 7141 F10
- 7142 F10

LEGEND

- * ... only assembled in FM/AM-version
- Ⓧ ... for provision only
- USA ... for USA version only
- LW ... for LW version only
- SMD jumper
- Ⓧ EVM
- ...V FM mode stereo
- ...V MW mode
- ...V LW mode
- voltages measured while set is tuned to a strong transmitter
- Signal path
- FM
- - - AM
- ⋯ MPX (Audio Frequency)
- ⇒ AF - left/right

1101 B5 1110 B4 1131 C5 2107 B3 2133 C1 2162 A4 5102 C4 5110 A2 5114 A2 5121 B2 7104 C4 9101 A2 9104 B1 9107 B4 9110 A4
 1102 B5 1120 A4 1132 A4 2128 A3 2138 B1 2191 B4 5103 C4 5111 A3 5115 C2 5122 C3 7105 C5 9102 B2 9105 B1 9108 B3 9111 A3
 1103 C5 1130 A5 2106 B4 2129 B3 2144 B1 3142 C2 5109 B3 5112 A2 5119 B2 5123 C3 7112 B1 9103 A1 9106 B1 9109 C2

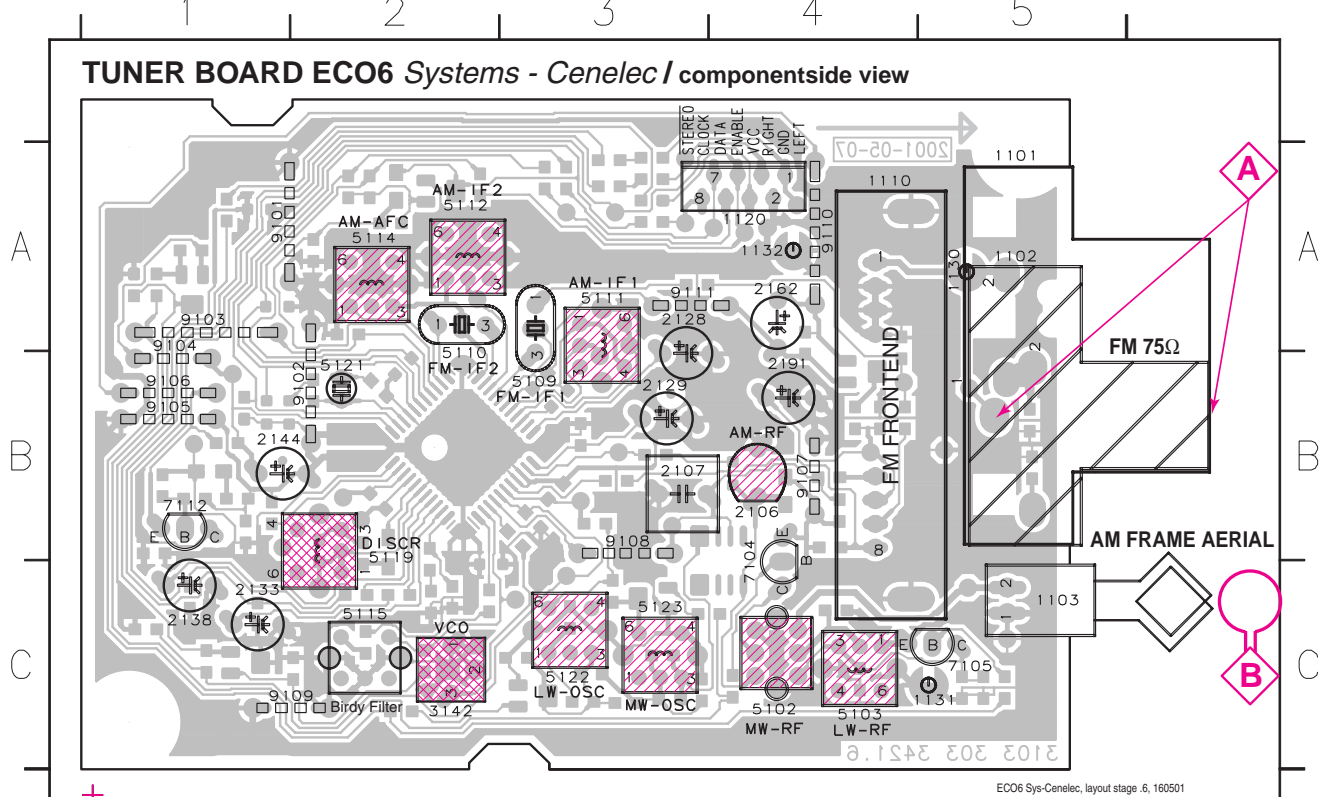

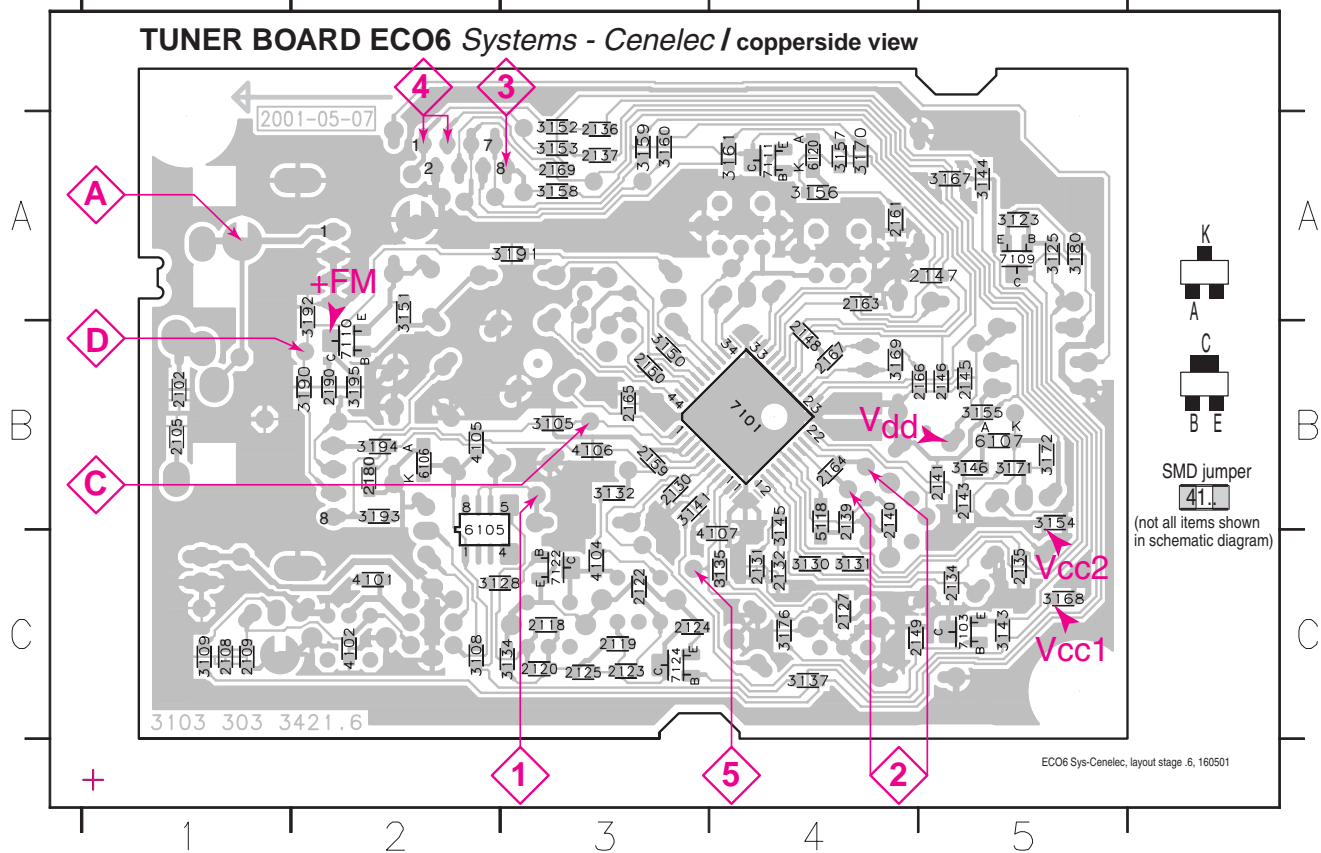

2102 B1 2120 C3 2130 B3 2137 A3 2146 B5 2161 A4 2169 A3 3123 A5 3134 C3 3145 C4 3154 B5 3160 A3 3171 B5 3192 A2 4104 C3 6106 B2 7110 B2
 2105 B1 2122 C3 2131 C4 2139 B4 2147 A5 2163 A4 2180 B2 3125 A5 3135 C4 3146 B5 3155 B5 3161 A4 3172 B5 3193 B2 4105 B2 6107 B5 7111 A4
 2108 C1 2123 C3 2132 C4 2140 B4 2148 B4 2164 B4 2190 B2 3128 C2 3137 C4 3150 B3 3156 A4 3167 A5 3176 C4 3194 B2 4106 B3 6120 A4 7122 C3
 2109 C1 2124 C3 2134 C5 2141 B5 2149 C4 2165 B3 3105 B3 3130 C4 3141 B3 3151 A2 3157 A4 3168 C5 3180 A5 3195 B2 4107 C4 7101 B4 7124 C3
 2118 C3 2125 C3 2135 C5 2143 B5 2150 B3 2166 B5 3108 C2 3131 C4 3143 C5 3152 A3 3158 A3 3169 B4 3190 B2 4101 C2 5118 C4 7103 C5
 2119 C3 2127 C4 2136 A3 2145 B5 2159 B3 2167 B4 3109 C1 3132 B3 3144 A5 3153 A3 3159 A3 3170 A4 3191 A3 4102 C2 6105 B2 7109 A5

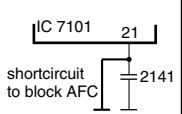
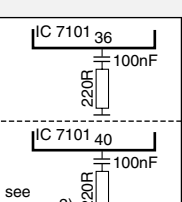
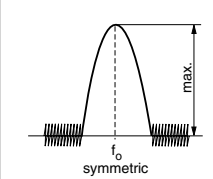

These assembly drawings show a summary of all possible versions.
 For components used in a specific version see schematic diagram respectively partslist.

TUNER ADJUSTMENT TABLE (ECO6 Cenelec FM/MW - and FM/MW/LW - versions with AM-frame aerial)

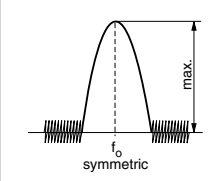
Waverange	Input frequency	Input	Tuned to	Adjust	Output	Scope/Voltmeter
<i>VARICAP ALIGNMENT</i>						
FM 87.5 - 108MHz (50kHz grid)			108MHz	check		8V ±1.2V
			87.5MHz	check		1.6V ±0.5V
MW 531 - 1602kHz (9kHz grid)			1602kHz	5123	1	8V ±0.2V 3-band 6.9V ±0.2V 2-band
			531kHz	check		1.1V ±0.4V
LW 153 - 279kHz (3kHz grid)			279kHz	5122		8V ±0.2V
			153kHz	check		1.1V ±0.4V
<i>FM - IF</i>						
FM	10.7MHz, 45mV continuous wave	D		5119	2	0mV ±3mV
<i>FM - VCO</i>						
FM	98MHz, 1mV continuous wave	A	98MHz	3142	3	152kHz ±1kHz ¹⁾
<i>FM RF (channel separation)</i> Note: The FM-frontend unit has already been adjusted by the factory and needs therefore no further adjustments for service purposes.						
FM	98MHz, 1mV 90% Left + 9% pilot mod=1kHz	A	98MHz	IF coil inside FM frontend 1110	4	right channel min.
<i>AM IF</i>						
MW	450kHz connect pin 6 of IC 7101 (AM Osc.) with 3.3kΩ to Vcc	C $\Delta f = \pm 10\text{kHz}$ $V_{RF} = 0.5\text{mV}$ (as low as possible)		5111	5	
			see remark 2)	5112		
AM AFC MW		C continuous wave $V_{RF} = 2\text{mV}$		5114	2	0mV ±2mV
<i>AM RF ³⁾</i>						
MW	1494kHz	B 	1494kHz	2106	5	
	558kHz		5102			
LW	198kHz	$\Delta f = \pm 30\text{kHz}$ V_{RF} as low as possible	198kHz	5103		

Use Service Testprogram. By selecting the TUNER TEST test frequencies will be stored as preset frequencies automatically.
¹⁾ If sensitivity of frequency counter is too low adjust to max. channel separation (input signal: stereo left 90% + 9%, adjust output on right channel to minimum)
²⁾ RC network serves for damping the IF-filter while adjusting the other one.
³⁾ For AM RF adjustments the original frame antenna has to be used!
 MW has to be aligned before LW.
 ↑ Repeat

MISCELLANEOUS

1101	2422 015 19376	SOCKET CLICKFIT 2P	USA only
1102	4822 267 10283	SOCKET COAX, IEC 75Ω	not USA
1103	4822 265 31184	JST CONNECTOR, 2 POLE	
1110	2422 542 90071	FM FRONTEND	
1120	4822 265 11515	FFC SOCKET, 8P	

CAPACITORS

2102	4822 126 13838	100nF 10% 50V	not USA
2105	4822 126 13838	100nF 10% 50V	USA only
2106	2020 800 00204	TRIMCAP. 4.2 - 20pF, N750	LW only
2106	2020 800 00191	TRIMCAP. 3 - 11pF, N450	FM/AM only
2107	4822 121 51319	1μF 20% 50V	
2108	5322 122 32531	100pF 5% 50V	LW only
2109	5322 122 32448	10pF 5% 50V	LW only
2120	4822 126 13689	18pF 1% 63V	FM/AM only
2120	5322 122 32658	22pF 5% 50V	LW only
2122	4822 122 33891	3,3nF 10% 63V	LW only
2123	2020 552 93494	390pF 1% 50V	LW only
2124	4822 122 33177	10nF 20% 50V	FM/AM only
2125	2020 552 96199	560pF 1% 50V	
2127	4822 126 14076	220nF 20% 25V	
2128	4822 124 40248	10μF 20% 63V	
2129	4822 124 41584	100μF 20% 10V	
2130	5322 122 32654	22nF 10% 63V	
2131	4822 126 13482	470nF 20% 16V	
2132	4822 126 13482	470nF 20% 16V	
2133	4822 124 21913	1μF 20% 63V	
2134	3198 017 31530	15nF 10% 50V	not USA
2134	5322 122 32654	22nF 10% 63V	USA only
2135	3198 017 31530	15nF 10% 50V	not USA
2135	3198 017 32230	22nF 10% 25V	USA only
2136	4822 126 14076	220nF 20% 25V	
2137	4822 126 14076	220nF 20% 25V	
2138	4822 124 22652	2,2μF 20% 50V	
2139	4822 126 14236	15pF 5% 50V	
2140	4822 126 13695	82pF 1% 63V	
2141	4822 126 13838	100nF 10% 50V	
2143	4822 126 14076	220nF 20% 25V	
2144	4822 124 21913	1μF 20% 63V	
2145	4822 122 33575	220pF 5% 50V	
2146	4822 122 33575	220pF 5% 50V	
2147	4822 122 33575	220pF 5% 50V	
2148	4822 122 33127	2,2nF 10% 63V	
2149	5322 122 32659	33pF 5% 50V	RDS only
2150	4822 126 13838	100nF 10% 50V	
2159	5322 122 31151	22μF 20% 50V	
2163	4822 126 13838	100nF 10% 50V	LW only
2164	4822 126 13482	470nF 20% 16V	
2165	4822 126 13838	100nF 10% 50V	
2166	5322 122 31647	1nF 10% 63V	
2167	4822 122 33926	12pF 5% 50V	
2169	4822 122 33127	2,2nF 10% 63V	RDS only
2180	3198 017 31030	10nF 10% 50V	
2190	4822 126 13838	100nF 10% 50V	
2191	4822 124 40178	100μF 20% 10V	

RESISTORS

3105	4822 117 11503	220Ω 5% 0,1W	
3108	4822 117 11449	2,2kΩ 1% 0,1W	LW only
3109	4822 051 20472	4,7kΩ 5% 0,1W	LW only
3123	4822 051 20472	4,7kΩ 5% 0,1W	LW only
3125	4822 117 10833	10kΩ 1% 0,1W	LW only

RESISTORS

3128	4822 117 11449	2,2kΩ 1% 0,1W	LW only
3130	3198 021 38210	820Ω 5% 0,06W	
3131	3198 021 38210	820Ω 5% 0,06W	
3132	4822 051 20479	47Ω 5% 0,1W	
3134	4822 051 20223	22kΩ 5% 0,1W	
3135	3198 021 31020	1kΩ 5% 0,06W	
3137	4822 051 20223	22kΩ 5% 0,1W	LW only
3141	4822 117 11148	56kΩ 1% 0,1W	
3142	4822 100 12159	TRIMPOT. 100kΩ	
3143	4822 051 20223	22kΩ 5% 0,1W	RDS only
3144	4822 051 10102	1kΩ 2% 0,25W	RDS only
3145	4822 117 11449	2,2kΩ 1% 0,1W	
3146	4822 051 20229	22Ω 5% 0,1W	
3150	4822 117 10833	10kΩ 1% 0,1W	
3151	4822 051 20683	68kΩ 5% 0,1W	
3152	4822 051 20471	470Ω 5% 0,1W	
3153	4822 051 20471	470Ω 5% 0,1W	
3154	4822 117 13577	330Ω 1% 0,1W	
3155	4822 117 10353	150Ω 5% 0,1W	
3156	4822 117 10837	100kΩ 1% 0,1W	
3157	4822 117 10837	100kΩ 1% 0,1W	
3158	4822 051 20471	470Ω 5% 0,1W	
3159	4822 051 20471	470Ω 5% 0,1W	
3160	4822 051 20471	470Ω 5% 0,1W	
3161	4822 051 20223	22kΩ 5% 0,1W	
3167	4822 051 20121	120Ω 5% 0,1W	
3168	4822 051 20121	120Ω 5% 0,1W	
3169	4822 051 20154	150kΩ 5% 0,1W	
3170	4822 117 10837	100kΩ 1% 0,1W	
3171	4822 117 10834	47kΩ 1% 0,1W	
3172	4822 051 20562	5,6kΩ 5% 0,1W	
3176	4822 051 20333	33kΩ 5% 0,1W	RDS only
3180	4822 117 10833	10kΩ 1% 0,1W	LW only
3190	4822 051 20121	120Ω 5% 0,1W	
3191	4822 051 20121	120Ω 5% 0,1W	
3192	4822 117 13577	330Ω 1% 0,1W	
3193	4822 117 13577	330Ω 1% 0,1W	
3194	4822 117 11449	2,2kΩ 1% 0,1W	
3195	4822 051 20101	100Ω 5% 0,1W	
4101	4822 051 20008	CHIP JUMPER 0805	FM/AM only
4102	4822 051 20008	CHIP JUMPER 0805	FM/AM only
4104	4822 051 20008	CHIP JUMPER 0805	FM/AM only
4105	4822 051 20008	CHIP JUMPER 0805	
4106	4822 051 20008	CHIP JUMPER 0805	
4107	4822 051 20008	CHIP JUMPER 0805	

COILS

5102	4822 157 71634	RF-COIL MW	
5103	2422 549 44107	RF-COIL LW	LW only
5109	4822 157 71639	FM-IF FILTER 10,7MHz	
5110	4822 242 70665	FM-IF FILTER 10,7MHz	
5111	2422 549 44023	AM-IF FILTER 450kHz	
5112	4822 157 70302	AM-IF FILTER 450kHz	
5114	4822 157 70302	AM-IF FILTER 450kHz	
5115	4822 157 71636	ANTI BIRDY FILTER	
5118	2422 535 95881	100nH	
5119	4822 157 11443	DISCRIMINATOR COIL	
5121	4822 242 10261	QUARTZ 75kHz	
5122	2422 549 44108	RF-COIL, LW-OSCILLATOR	LW only
5123	2422 549 44108	RF-COIL, MW-OSCILLATOR	

DIODES

6105	4822 130 83075	HN1V02H	
6106	4822 130 83757	BAS216	
6107	9340 386 90115	BZX284-C11	
6120	4822 130 83757	BAS216	

TRANSISTORS

7103	5322 130 42756	BC857C	RDS only
7104	9322 003 64676	TBC337-40	LW only
7105	9322 003 64676	TBC337-40	LW only
7109	4822 130 60373	BC856B	LW only
7110	4822 130 60373	BC856B	
7111	5322 130 42755	BC847C	
7112	4822 130 44503	BC547C	
7122	5322 130 42755	BC847C	LW only
7124	5322 130 42755	BC847C	LW only

INTEGRATED CIRCUITS

7101	4822 209 90315	TEA5762H/V1, RADIO IC	
------	----------------	-----------------------	--

MAINS BOARD

TABLE OF CONTENTS

Brief introduction	8-1
Mains Socket - Circuit diagram & Component layout	8-1
Mains Board - Component layout	8-2
Mains Board - Chip layout	8-3
Mains Board - Circuit diagram	8-4
Electrical parts list	8-5

Brief introduction of the Mains Board

ECO Power

Standby Transformer 5203 provides the LPS supply to control the relay 1210, cutting of the Mains supply to the Mains transformer during the ECO Power (standby) mode.

The Mains transformer provides the following:

- 5V6_ECO for Low Power Supply
- +A, +A/2 and +B to the Combi board

MAINS SOCKET - CIRCUIT DIAGRAM & COMPONENT LAYOUT

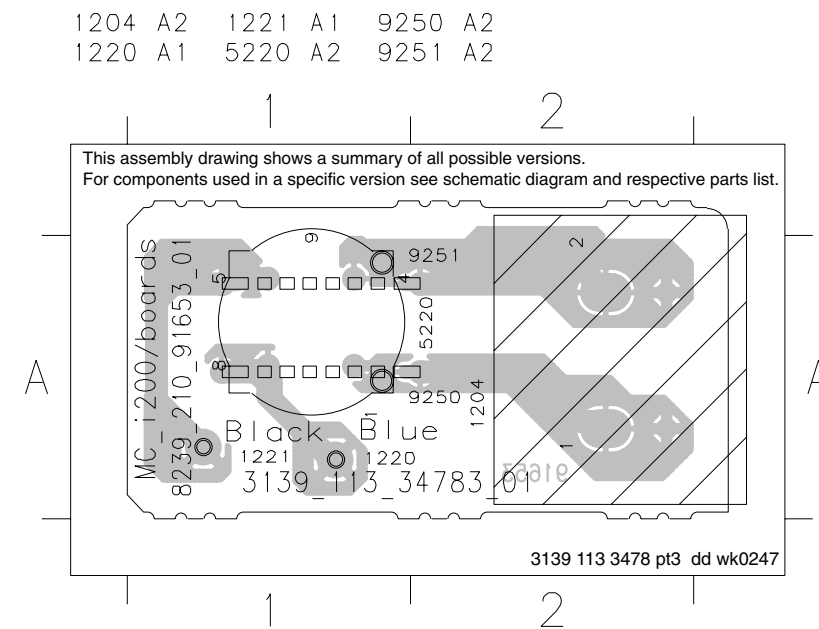

1204 A1 1220 A2 1221 A2 5220 A1 9250 A1 9251 A1

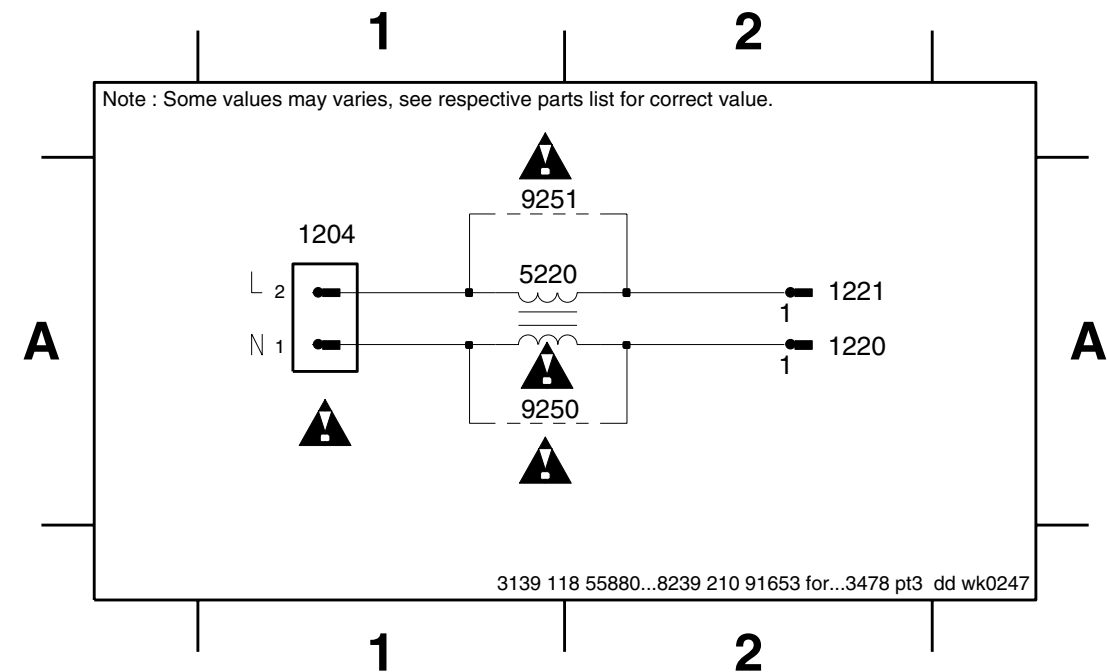

MAINS BOARD - COMPONENT LAYOUT

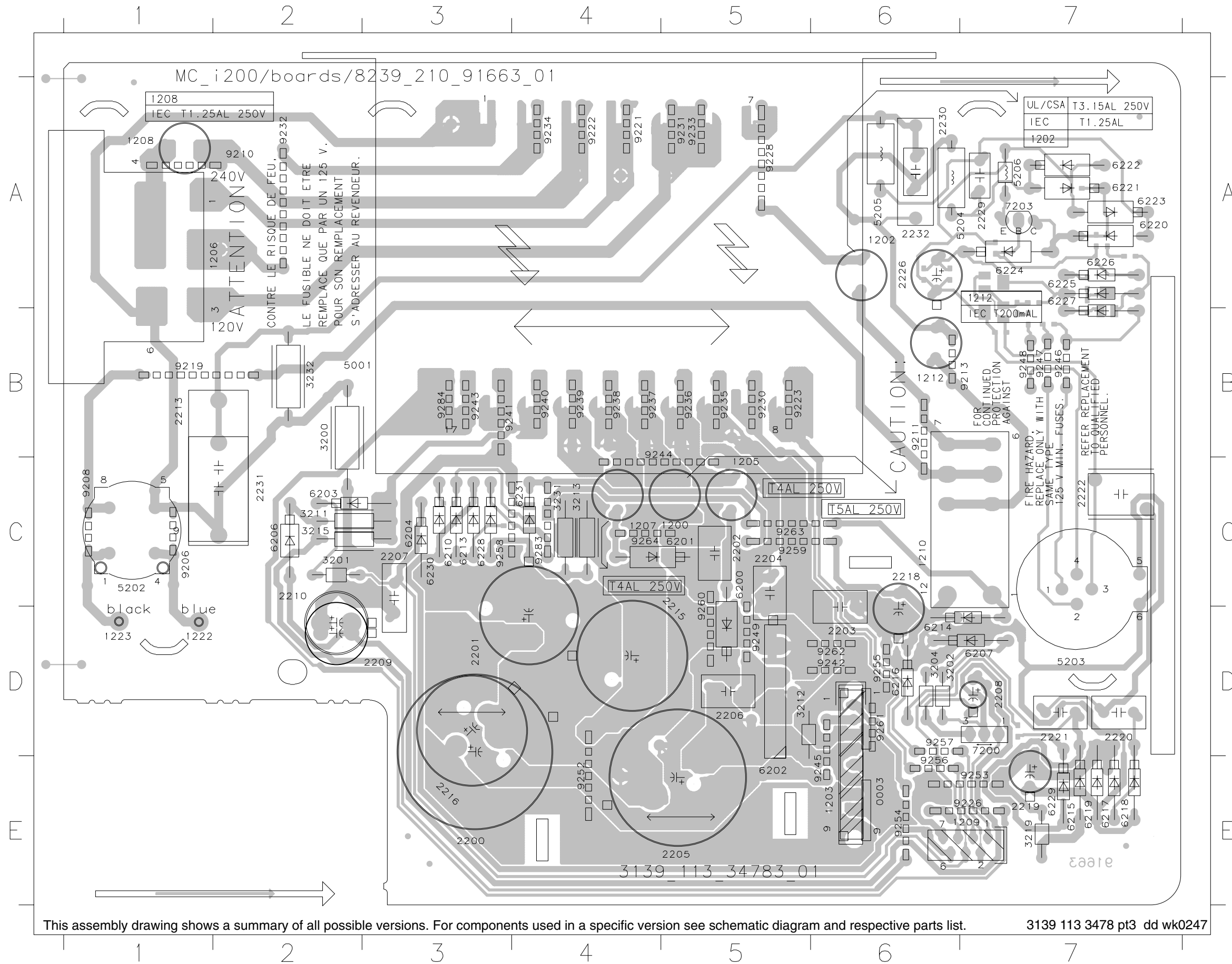

000	F6
1200	A6
1201	B6
1202	C6
1203	D6
1204	E6
1205	F6
1206	G6
1207	H6
1208	I6
1209	J6
1210	K6
1211	L6
1212	M6
1213	N6
1214	O6
1215	P6
1216	Q6
1217	R6
1218	S6
1219	T6
1220	U6
1221	V6
1222	W6
1223	X6
1224	Y6
1225	Z6
1226	AA6
1227	AB6
1228	AC6
1229	AD6
1230	AE6
1231	AF6
1232	AG6
1233	AH6
1234	AI6
1235	AJ6
1236	AK6
1237	AL6
1238	AM6
1239	AN6
1240	AO6
1241	AP6
1242	AQ6
1243	AR6
1244	AS6
1245	AT6
1246	AU6
1247	AV6
1248	AW6
1249	AX6
1250	AY6
1251	AZ6
1252	BA6
1253	BB6
1254	BC6
1255	BD6
1256	BE6
1257	BF6
1258	BG6
1259	BH6
1260	BI6
1261	BJ6
1262	BK6
1263	BL6
1264	BM6
1265	BN6
1266	BO6
1267	BP6
1268	BQ6
1269	BR6
1270	BS6
1271	BT6
1272	BU6
1273	BV6
1274	BW6
1275	BX6
1276	BY6
1277	BZ6
1278	CA6
1279	CB6
1280	CC6
1281	CD6
1282	CE6
1283	CF6
1284	CG6
1285	CH6
1286	CI6
1287	CJ6
1288	CK6
1289	CL6
1290	CM6
1291	CN6
1292	CO6
1293	CP6
1294	CQ6
1295	CR6
1296	CS6
1297	CT6
1298	CU6
1299	CV6
1300	CW6
1301	CX6
1302	CY6
1303	CZ6
1304	DA6
1305	DB6
1306	DC6
1307	DD6
1308	DE6
1309	DF6
1310	DG6
1311	DH6
1312	DI6
1313	DJ6
1314	DK6
1315	DL6
1316	DM6
1317	DN6
1318	DO6
1319	DP6
1320	DQ6
1321	DR6
1322	DS6
1323	DT6
1324	DU6
1325	DV6
1326	DW6
1327	DX6
1328	DY6
1329	DZ6
1330	EA6
1331	EB6
1332	EC6
1333	ED6
1334	EE6
1335	EF6
1336	EG6
1337	EH6
1338	EI6
1339	EJ6
1340	EK6
1341	EL6
1342	EM6
1343	EN6
1344	EO6
1345	EP6
1346	EQ6
1347	ER6
1348	ES6
1349	ET6
1350	EU6
1351	EV6
1352	EW6
1353	EX6
1354	EY6
1355	EZ6
1356	FA6
1357	FB6
1358	FC6
1359	FD6
1360	FE6
1361	FF6
1362	FG6
1363	FH6
1364	FI6
1365	FJ6
1366	FK6
1367	FL6
1368	FM6
1369	FN6
1370	FO6
1371	FP6
1372	FQ6
1373	FR6
1374	FS6
1375	FT6
1376	FU6
1377	FV6
1378	FW6
1379	FX6
1380	FY6
1381	FZ6
1382	GA6
1383	GB6
1384	GC6
1385	GD6
1386	GE6
1387	GF6
1388	GH6
1389	GI6
1390	GJ6
1391	GK6
1392	GL6
1393	GM6
1394	GN6
1395	GO6
1396	GP6
1397	GQ6
1398	GR6
1399	GS6
1400	GT6
1401	GU6
1402	GV6
1403	GW6
1404	GX6
1405	GY6
1406	GZ6
1407	HA6
1408	HB6
1409	HC6
1410	HD6
1411	HE6
1412	HF6
1413	HG6
1414	HH6
1415	HI6
1416	HJ6
1417	HK6
1418	HL6
1419	HM6
1420	HN6
1421	HO6
1422	HP6
1423	HQ6
1424	HR6
1425	HS6
1426	HT6
1427	HU6
1428	HV6
1429	HW6
1430	HX6
1431	HY6
1432	HZ6
1433	IA6
1434	IB6
1435	IC6
1436	ID6
1437	IE6
1438	IF6
1439	IG6
1440	IH6
1441	II6
1442	IJ6
1443	IK6
1444	IL6
1445	IM6
1446	IN6
1447	IO6
1448	IP6
1449	IQ6
1450	IR6
1451	IS6
1452	IT6
1453	IU6
1454	IV6
1455	IW6
1456	IX6
1457	IY6
1458	IZ6
1459	JA6
1460	JB6
1461	JC6
1462	JD6
1463	JE6
1464	JF6
1465	JG6
1466	JH6
1467	JI6
1468	IJ6
1469	JK6
1470	IL6
1471	JM6
1472	JN6
1473	JO6
1474	JP6
1475	JK6
1476	JL6
1477	JM6
1478	JN6
1479	JO6
1480	JP6
1481	JK6
1482	JL6
1483	JM6
1484	JN6
1485	JO6
1486	JP6
1487	JK6
1488	JL6
1489	JM6
1490	JN6
1491	JO6
1492	JP6
1493	JK6
1494	JL6
1495	JM6
1496	JN6
1497	JO6
1498	JP6
1499	JK6
1500	JL6

This assembly drawing shows a summary of all possible versions. For components used in a specific version see schematic diagram and respective parts list. 3139 113 3478 pt3 dd wk0247

MAINS BOARD - CHIP LAYOUT

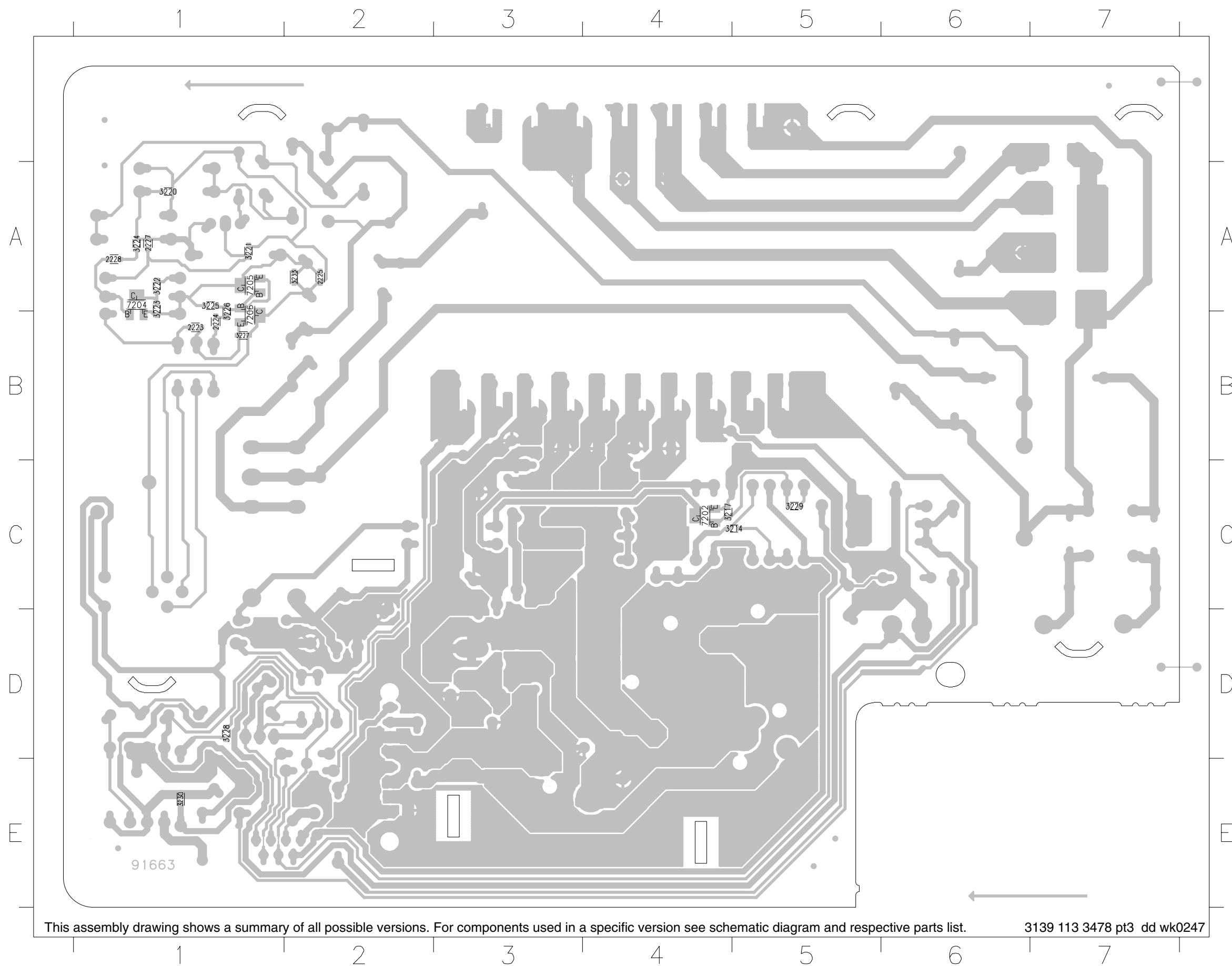

- 2223 B1
- 2224 B1
- 2225 A2
- 2227 A1
- 2228 A1
- 3214 C5
- 3217 C4
- 3220 A1
- 3221 A1
- 3222 A1
- 3223 A1
- 3224 A1
- 3225 A1
- 3226 B1
- 3227 B1
- 3228 D1
- 3229 C5
- 3230 E1
- 3233 A2
- 7202 C4
- 7204 A1
- 7205 A1
- 7206 B1

This assembly drawing shows a summary of all possible versions. For components used in a specific version see schematic diagram and respective parts list. 3139 113 3478 pt3 dd wk0247

MAINS BOARD - CIRCUIT DIAGRAM

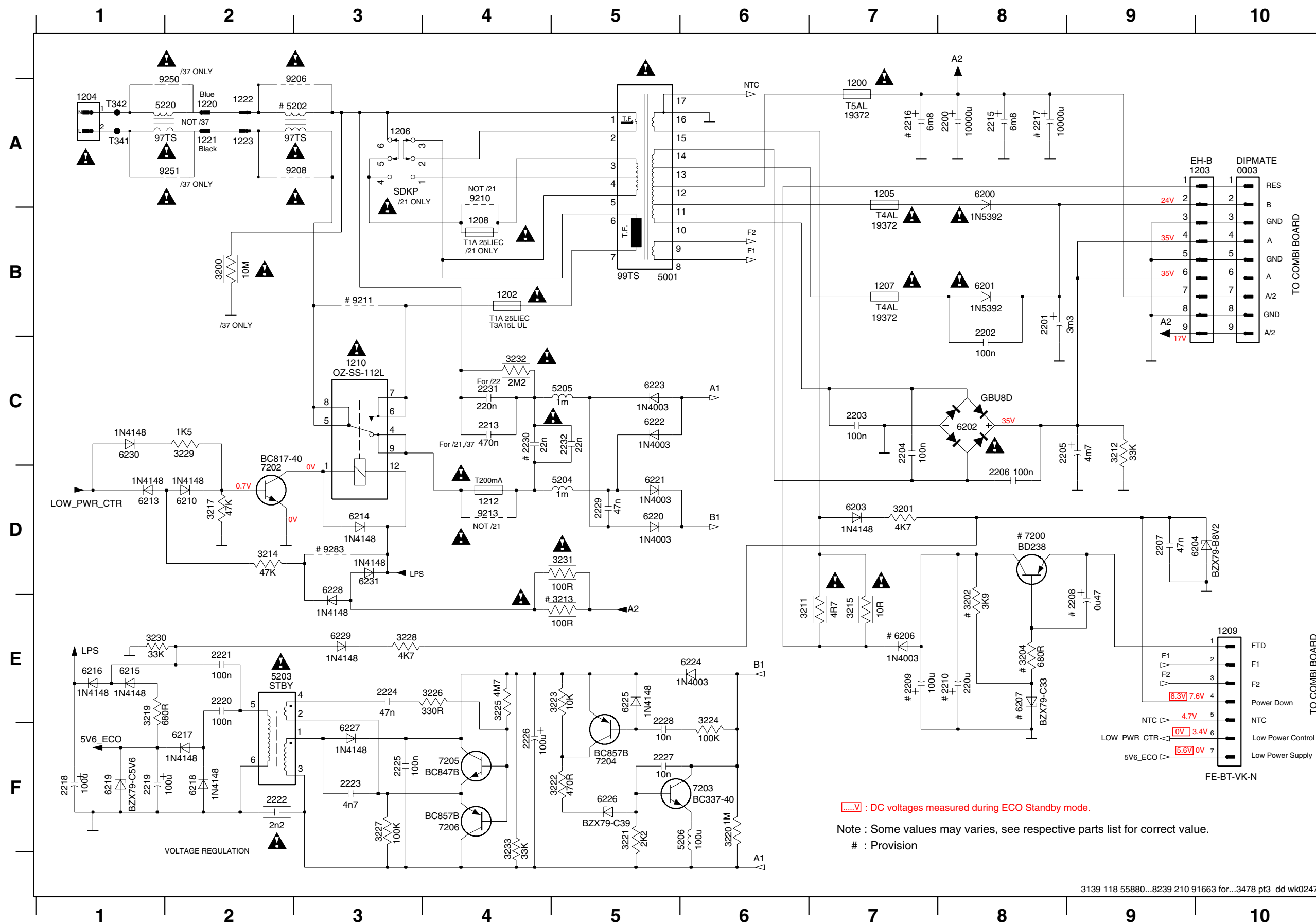

- 0003 A10
- 1200 A7
- 1202 B4
- 1203 A9
- 1205 A7
- 1206 A3
- 1207 B7
- 1208 B4
- 1209 E10
- 1210 C3
- 1212 D4
- 1222 A2
- 1223 A2
- 2200 A8
- 2201 B8
- 2202 B8
- 2203 C7
- 2204 C7
- 2205 C8
- 2206 D8
- 2207 D9
- 2208 E9
- 2209 E7
- 2210 E8
- 2213 C4
- 2215 A8
- 2216 A7
- 2217 A8
- 2218 F1
- 2219 F1
- 2220 E2
- 2221 E2
- 2222 F2
- 2223 F3
- 2224 E3
- 2225 F3
- 2226 F4
- 2227 F5
- 2228 E5
- 2229 D5
- 2230 C4
- 2231 C4
- 2232 C5
- 3200 B2
- 3201 D7
- 3202 E8
- 3204 E8
- 3211 E6
- 3212 C9
- 3213 E5
- 3214 D2
- 3215 E7
- 3217 D2
- 3219 E1
- 3220 F6
- 3221 F5
- 3222 F5
- 3223 E5
- 3224 F6
- 3225 E4
- 3226 E4
- 3227 F3
- 3228 E3
- 3229 C2
- 3230 E1
- 3231 D5
- 3232 C4
- 3233 F4
- 5001 B5
- 5202 A3
- 5203 E3
- 5204 D5
- 5205 C5
- 5206 F6
- 6200 A8
- 6201 B8
- 6202 C8
- 6203 D7
- 6204 D9
- 6206 E7
- 6207 E8
- 6210 D2
- 6213 D1
- 6214 D3
- 6215 E1
- 6216 E1
- 6217 F2
- 6218 F2
- 6219 F1
- 6220 D5
- 6221 D5
- 6222 C5
- 6223 C5
- 6224 E6
- 6225 E5
- 6226 F5
- 6227 F3
- 6228 D3
- 6229 E3
- 6230 C1
- 6231 D3
- 7200 D8
- 7202 D2
- 7203 F6
- 7204 E5
- 7205 F4
- 7206 A3
- 9208 A3
- 9210 A4
- 9211 B3
- 9213 D4
- 9283 D3

[...V] : DC voltages measured during ECO Standby mode.
 Note : Some values may varies, see respective parts list for correct value.
 # : Provision

ELECTRICAL PARTS LIST - MAINS BOARD**MISCELLANEOUS**

1200	2422 086 10963	△ Fuse RAD LT 5A
1202	4822 071 51252	△ Fuse RAD LT 1,25A /21M/22
1202	4822 252 51121	△ Fuse RAD LT 3,15A /37
1204	4822 265 31015	△ Mains Socket /21M/22
1204	2422 030 00328	△ Mains Socket /37
1205	2422 086 10786	△ Fuse RAD LT 4A
1206	9965 000 07789	△ Voltage Selector /21M
1207	2422 086 10786	△ Fuse RAD LT 4A
1208	4822 071 51252	△ Fuse RAD LT 1,25A /21M
1209	4822 267 10953	Flex Connector 7P
1210	2422 132 07519	△ Relay 1P 12V 16A OZ-SS L
1212	4822 071 52001	△ Fuse RAD LT 200mA /21M

CAPACITORS

2200	2022 020 00646	10000uF 20% 25V
2201	4822 124 42367	3300uF 20% 35V
2202	5322 121 42386	100nF 5% 63V
2203	5322 121 42386	100nF 5% 63V
2204	5322 121 42386	100nF 5% 63V
2205	4822 124 80415	4700uF 20% 50V
2206	5322 121 42386	100nF 5% 63V
2207	4822 126 14559	47nF 50V
2213	4822 126 13589	470nF 275V /21M/37
2215	9965 000 12531	6800uF 25V 20%
2218	2020 012 93583	100uF 20% 25V
2219	4822 124 23052	100uF 20% 16V
2220	5322 121 42386	100nF 5% 63V
2221	5322 121 42386	100nF 5% 63V
2222	4822 126 14088	△ 2,2nF 20% 250V
2223	4822 126 13193	4,7nF 10% 63V
2224	3198 017 34730	47nF 16V
2225	2238 586 59812	100nF 50V
2226	4822 124 40255	100uF 20% 63V
2227	5322 126 11583	10nF 10% 50V
2228	5322 126 11583	10nF 10% 50V
2229	4822 121 43526	47nF 5% 250V
2231	4822 121 10512	220nF 20% 275V /22
2232	2222 336 19106	△ 22nF 20% 275V

RESISTORS

3200	4822 053 21106	△ 10M 5% 0,5W /37
3201	4822 116 52283	4k7 5% 0,5W
3211	4822 052 10478	△ 4R7 5% 0,33W
3212	4822 050 23303	33k 1% 0,6W
3214	4822 117 12925	47k 1% 0,063W
3215	4822 052 10109	△ 10R 5% 0,33W
3217	4822 117 12925	47k 1% 0,063W
3219	4822 116 52228	680R 5% 0,5W
3220	4822 051 30105	1M 5% 0,062W
3221	4822 051 30222	2k2 5% 0,062W
3222	4822 051 30471	470R 5% 0,062W

3223	4822 051 30103	10k 5% 0,062W
3224	4822 117 13632	100k 1% 0,62W
3225	4822 051 30475	4M7 5% 0,062W
3226	4822 051 30331	330R 5% 0,062W
3227	4822 117 13632	100k 1% 0,62W
3228	4822 051 30472	4k7 5% 0,062W
3229	4822 051 30152	1k5 5% 0,062W
3230	4822 051 30333	33k 5% 0,062W
3231	4822 052 10101	△ 100R 5% 0,33W
3232	4822 053 21225	△ 2M2 5% 0,5W
3233	4822 051 30333	33k 5% 0,062W

COILS & FILTERS

5203	2422 549 45157	△ TRAFO STANDBY 3A1631N
5204	4822 157 53473	Coil 1000uH 10%
5205	4822 157 53473	Coil 1000uH 10%
5206	4822 157 11228	Coil 100uH 5%
5220	4822 157 11832	△ 400uH 3A /21M/22

DIODES

6200	4822 130 31878	△ 1N4003G
6200	5322 130 80686	△ 1N5392
6201	4822 130 31878	△ 1N4003G
6201	5322 130 80686	△ 1N5392
6202	4822 130 11139	△ GBU8D
6203	4822 130 30621	1N4148
6204	4822 130 34382	BZX79-B8V2
6210	4822 130 30621	1N4148
6213	4822 130 30621	1N4148
6214	4822 130 30621	1N4148
6215	4822 130 30621	1N4148
6216	4822 130 30621	1N4148
6217	4822 130 30621	1N4148
6218	4822 130 30621	1N4148
6219	4822 130 34173	BZX79-C5V6
6220	4822 130 31878	1N4003G
6221	4822 130 31878	1N4003G
6222	4822 130 31878	1N4003G
6223	4822 130 31878	1N4003G
6224	4822 130 31878	1N4003G
6225	4822 130 30621	1N4148
6226	4822 130 34145	BZX79-C39
6227	4822 130 30621	1N4148
6228	4822 130 30621	1N4148
6229	4822 130 30621	1N4148
6230	4822 130 30621	1N4148
6231	4822 130 30621	1N4148

TRANSISTORS & INTEGRATED CIRCUITS

7202	4822 130 42615	BC817-40
7203	4822 130 40855	BC337-40

ELECTRICAL PARTS LIST - MAINS BOARD

TRANSISTORS & INTEGRATED CIRCUITS

7204	4822 130 60373	BC857B
7205	5322 130 60159	BC847B
7206	4822 130 60373	BC857B

Note : Only the parts mentioned in this list are normal service spare parts.

COMBI & REGULATOR BOARDS

TABLE OF CONTENTS

Brief Introduction of the Regulator & Combi Boards	9-1
Regulator Board - Component & Copper side layout	9-2
Regulator Board - Circuit diagram	9-3
Combi Board - Chip layout	9-4
Combi Board - Component layout	9-5
Combi Circuit - Power Amplifier part	9-6
Combi Circuit - Source Select & Sound Control part	9-7
Combi Circuit - Headphone Amplifier part	9-8
Combi Circuit - Connector part	9-9
Electrical parts list	9-10

Brief introduction of the Regulator Board

The regulator board provides the following:

- a) 12V supply : +12V_A and +12V_D derived from the +A supply
- b) 5,6V and 5V supply : +5V6 and 5V_iAM derived from the +A/2 supply

Brief introduction of the Combi Board

1. Source select & Sound control
Audio Processor IC 7506 (TDA7468D) provides the source selection and sound control features via the I2C bus (I2C_CLK and I2C_DATA lines).
2. Line out
Line out is taken directly from the Audio Processor IC 7506. Muting is done via transistors 7003, 7007 and 7008.
3. Pre-amplifier
IC 7700 (NJM4556AM) provides pre-amplification of the output signals from the Audio Processor IC 7506. Muting of audio signals to Power Amplifier IC 7301 and 7302 during Headphone application and Source switching is done via transistors 7328 and 7329.
4. Headphone and Subwoofer outputs
The Headphone and Subwoofer outputs are taken from the pre-amplifier out. Muting of these outputs are done via transistors 7004, 7009, 7011 and 7012.
5. Power Amplifier
IC 7301 and 7302 (AN7591) are used as Power Amplifier. They function as Super Class G Amplifier together with transistors 7304 and 7309 (STP16NE06) which switches the supply between supply source A1, B1 and C1.
6. I/O Expander
I/O Expander IC 7005 (M62320FP) converts the I2C bus (I2C_CLK and I2C_DATA lines) into additional control lines.

REGULATOR BOARD - COMPONENT SIDE VIEW

0003 A4	2406 A3	3404 A3	3414 A2	3424 A1	3435 A3	6407 A2	7406 B4	7415 A1
1171 A4	2407 A4	3405 B2	3415 B3	3425 A2	3440 A1	6411 A4	7407 B4	9401 A2
1400 A4	2411 A4	3406 B2	3416 B3	3426 A1	3441 A3	6412 A3	7408 B2	9402 A1
1401 A4	2412 A2	3407 A2	3417 B2	3427 A2	6400 B2	6413 A3	7409 A3	9403 B1
2400 B1	2413 A2	3409 B3	3418 A1	3428 A2	6401 B2	7401 B1	7410 A1	9404 A4
2402 B4	2414 A2	3410 B4	3419 A4	3431 A2	6402 B3	7402 B2	7411 A3	9405 A4
2403 B3	2415 A3	3411 A1	3420 A4	3432 A1	6404 B3	7403 A1	7412 A3	9406 A2
2404 B3	2416 A4	3412 A2	3421 A3	3433 A3	6405 B3	7404 A3	7413 A1	9407 A2
2405 A3	3403 B2	3413 A2	3423 A1	3434 A3	6406 A4	7405 A1	7414 A2	

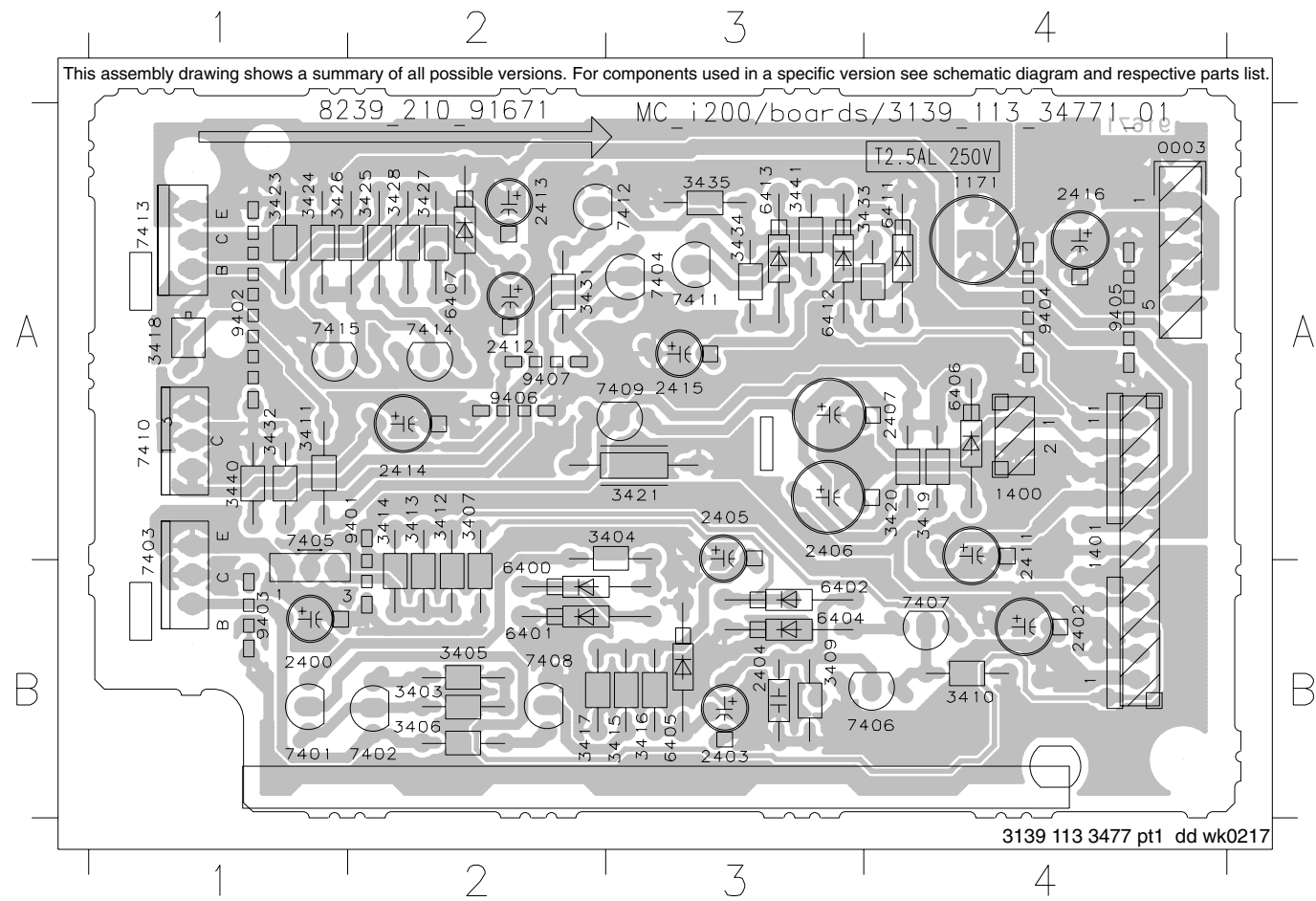

REGULATOR BOARD - COPPER SIDE VIEW

0003 A1	2406 A2	3404 A2	3414 B3	3424 A4	3435 A2	6407 A3	7406 B1	7415 A4
1171 A1	2407 A2	3405 B3	3415 B2	3425 A3	3440 A4	6411 A1	7407 B1	9401 B3
1400 A1	2411 A1	3406 B3	3416 B2	3426 A3	3441 A2	6412 A2	7408 B3	9402 A4
1401 A1	2412 A3	3407 B3	3417 B3	3427 A3	6400 B3	6413 A2	7409 A2	9403 B4
2400 B4	2413 A3	3409 B2	3418 A4	3428 A3	6401 B3	7401 B4	7410 A4	9404 A1
2402 B1	2414 A3	3410 B1	3419 A1	3431 A3	6402 B2	7402 B3	7411 A2	9405 A1
2403 B2	2415 A2	3411 A4	3420 A1	3432 A4	6404 B2	7403 B4	7412 A2	9406 A3
2404 B2	2416 A1	3412 B3	3421 A2	3433 A1	6405 B2	7404 A2	7413 A4	9407 A3
2405 A2	3403 B3	3413 B3	3423 A4	3434 A2	6406 A1	7405 A4	7414 A3	

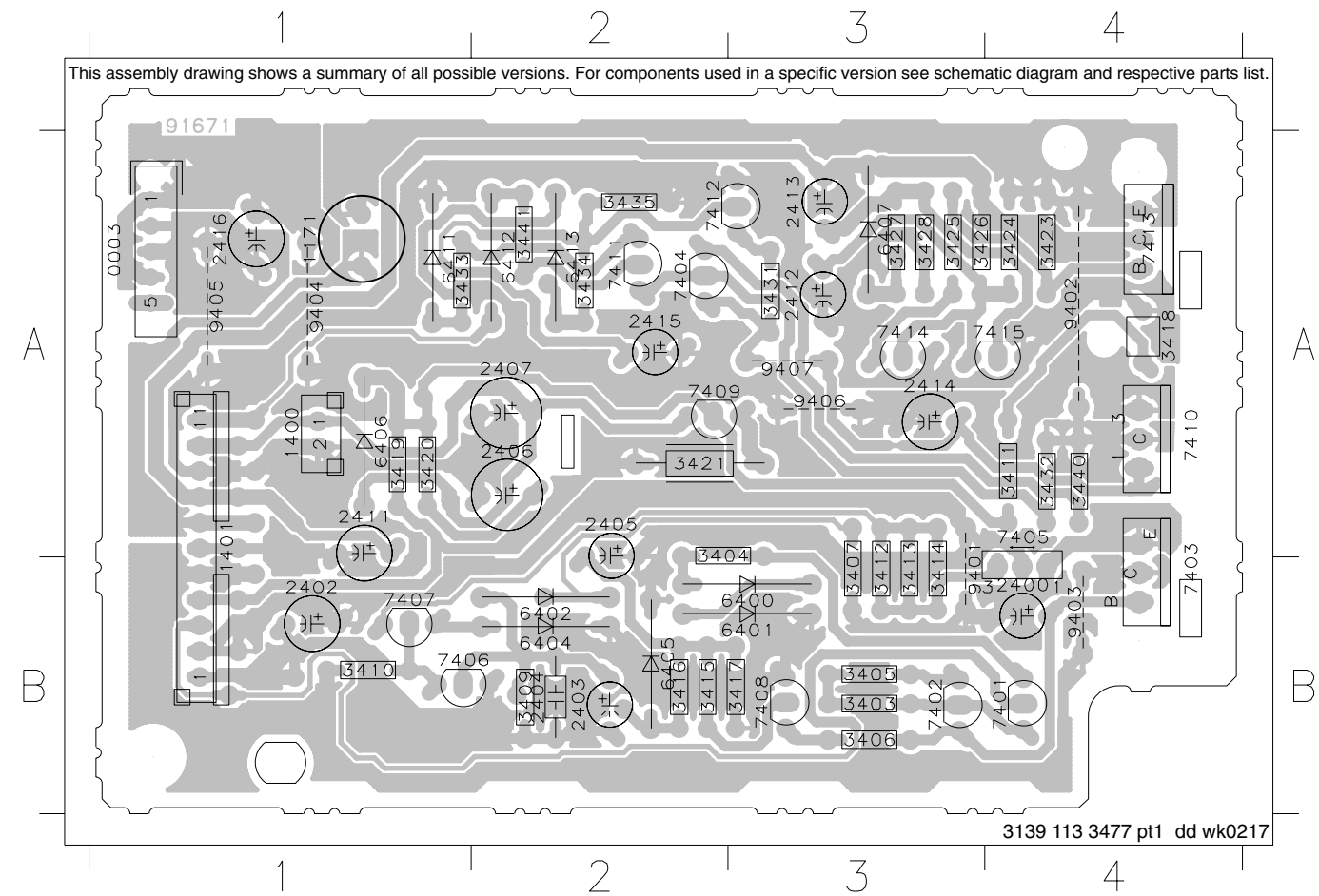

REGULATOR BOARD - CIRCUIT DIAGRAM

0003 D1	1401 C1	2403 C5	2406 B8	2412 E4	2415 D7	3404 B4	3407 B5	3411 B8	3414 B6	3417 C7	3420 B8	3424 D3	3427 D5	3432 D6	3435 E7	6400 B4	6404 C6	6407 D5	6413 D7	7403 A5	7406 B6	7409 B9	7412 E7	7415 E4
1171 D3	2400 A5	2404 C5	2407 B8	2413 D4	2416 E8	3405 A4	3409 C5	3412 B6	3415 B7	3418 B8	3421 A8	3425 D4	3428 E5	3433 E6	3440 D6	6401 C4	6405 B7	6411 E6	7401 A4	7404 D6	7407 B6	7410 C7	7413 C3	9401 A6
1400 B9	2402 A7	2405 B7	2411 C3	2414 D7	3403 A4	3406 B5	3410 B6	3413 B6	3416 B7	3419 A8	3423 D3	3426 D4	3431 E7	3434 D7	3441 D5	6402 B5	6406 B8	6412 D5	7402 A4	7405 A6	7408 B7	7411 D6	7414 D4	

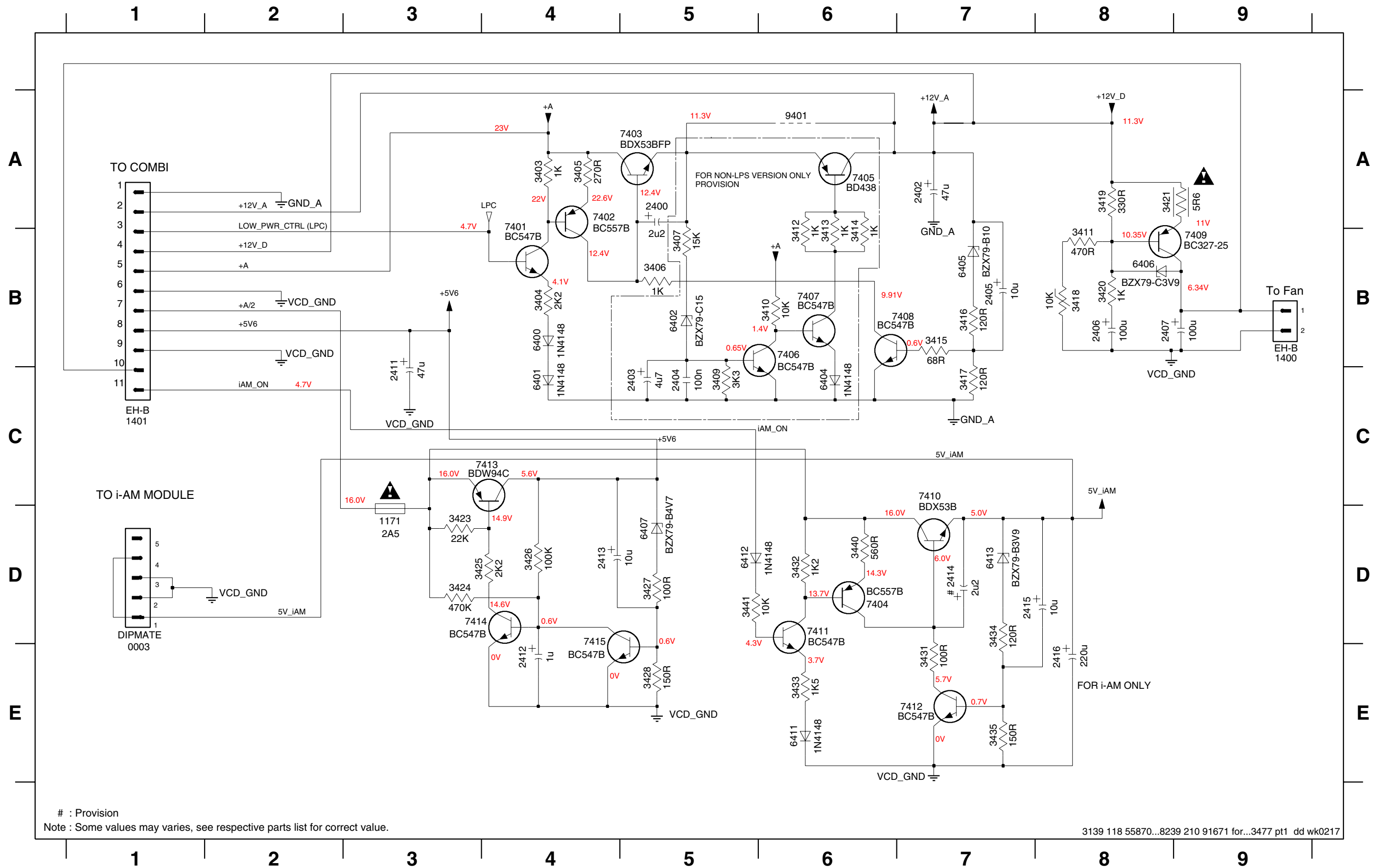

COMBI BOARD - CHIP LAYOUT

2000	D3	2060	B3	2308	C8	2510	C4	2706	F2	3028	C1	3050	D3	3079	C1	3099	A8	3307	E8	3360	F4	3508	C4	3704	E2	3806	B2	4211	B1	4231	B2	5306	C4	7300	F7
2003	A4	2061	B1	2315	C8	2521	C2	2707	F1	3029	B5	3051	B8	3081	C9	3100	A8	3308	C8	3361	F3	3509	C2	3705	F2	3807	C4	4212	C2	4232	E3	7000	D1	7307	F6
2006	A4	2062	B1	2316	E8	2522	C4	2709	E1	3031	B1	3052	D2	3082	C9	3101	A8	3314	E6	3362	F3	3510	D4	3706	E1	3808	C3	4213	D2	4233	C1	7003	B9	7308	F7
2025	B9	2063	A9	2324	F6	2523	C2	2713	E1	3032	F1	3053	A6	3083	B3	3102	A8	3318	F6	3363	F3	3511	C3	3707	F1	3809	B3	4214	D1	4234	C1	7004	F1	7310	F6
2028	B3	2064	A9	2339	F4	2524	C4	2715	F1	3033	F1	3054	C1	3084	B3	3105	E2	3323	F7	3364	F7	3512	C4	3709	E1	3810	C4	4215	E1	4235	C1	7005	B1	7313	F7
2031	B9	2065	A9	2340	F5	2525	C3	2717	B3	3034	B1	3057	F1	3085	A3	3106	E1	3326	F8	3365	F7	3513	C2	3711	E1	3811	B2	4216	F1	4237	D2	7006	A6	7325	F3
2035	B9	2066	A9	2501	C3	2530	C4	2718	B3	3035	C1	3059	C1	3087	B4	3107	B1	3327	F8	3367	F5	3516	C4	3712	E1	4202	B3	4217	F2	4238	D2	7007	B9	7326	F7
2036	B9	2067	A9	2502	C4	2544	D3	3014	C1	3036	B4	3060	C1	3088	B3	3110	B5	3328	D8	3377	D5	3540	D3	3714	E1	4203	B4	4219	E3	4239	D2	7008	D1	7328	F4
2037	B9	2068	A8	2503	C3	2546	B3	3017	A4	3038	B9	3062	A6	3089	A3	3111	B5	3329	F7	3378	D5	3541	D3	3715	B1	4204	B3	4220	E3	4240	E3	7009	F1	7329	E4
2038	F1	2070	B1	2504	C4	2549	B3	3018	A4	3039	B8	3064	B4	3091	B4	3301	F8	3331	E6	3379	F4	3543	B3	3800	A7	4205	B3	4225	E4	4241	E3	7010	A6	7505	B3
2042	B9	2301	E8	2505	C3	2552	C3	3021	B9	3041	D3	3065	F1	3094	A1	3302	C8	3336	E7	3380	E4	3544	C3	3801	A8	4206	B4	4226	E4	4242	A8	7011	C9	7506	C3
2043	A9	2302	C8	2506	C4	2563	B3	3022	B5	3042	F1	3066	F1	3095	A1	3303	E8	3337	C7	3503	C2	3565	C4	3802	A8	4207	B3	4227	C2	4243	A8	7012	B9	7700	E1
2045	F1	2303	E8	2507	C3	2564	B3	3024	B5	3043	D2	3071	C1	3096	E2	3304	D8	3341	F8	3505	C3	3566	B3	3803	A7	4208	C4	4228	F4	4244	A8	7013	D1		
2051	C9	2304	C8	2508	C4	2700	E1	3026	B9	3048	A6	3073	C9	3097	E1	3305	F4	3342	F7	3506	C4	3700	E2	3804	C2	4209	C3	4229	A1	4252	C2	7015	A3		
2057	B8	2307	E8	2509	C3	2702	E2	3027	B5	3049	B9	3077	C9	3098	A9	3306	E4	3342	F7	3507	C2	3701	E2	3805	C4	4210	B1	4230	A1	5305	C3	7016	AB		

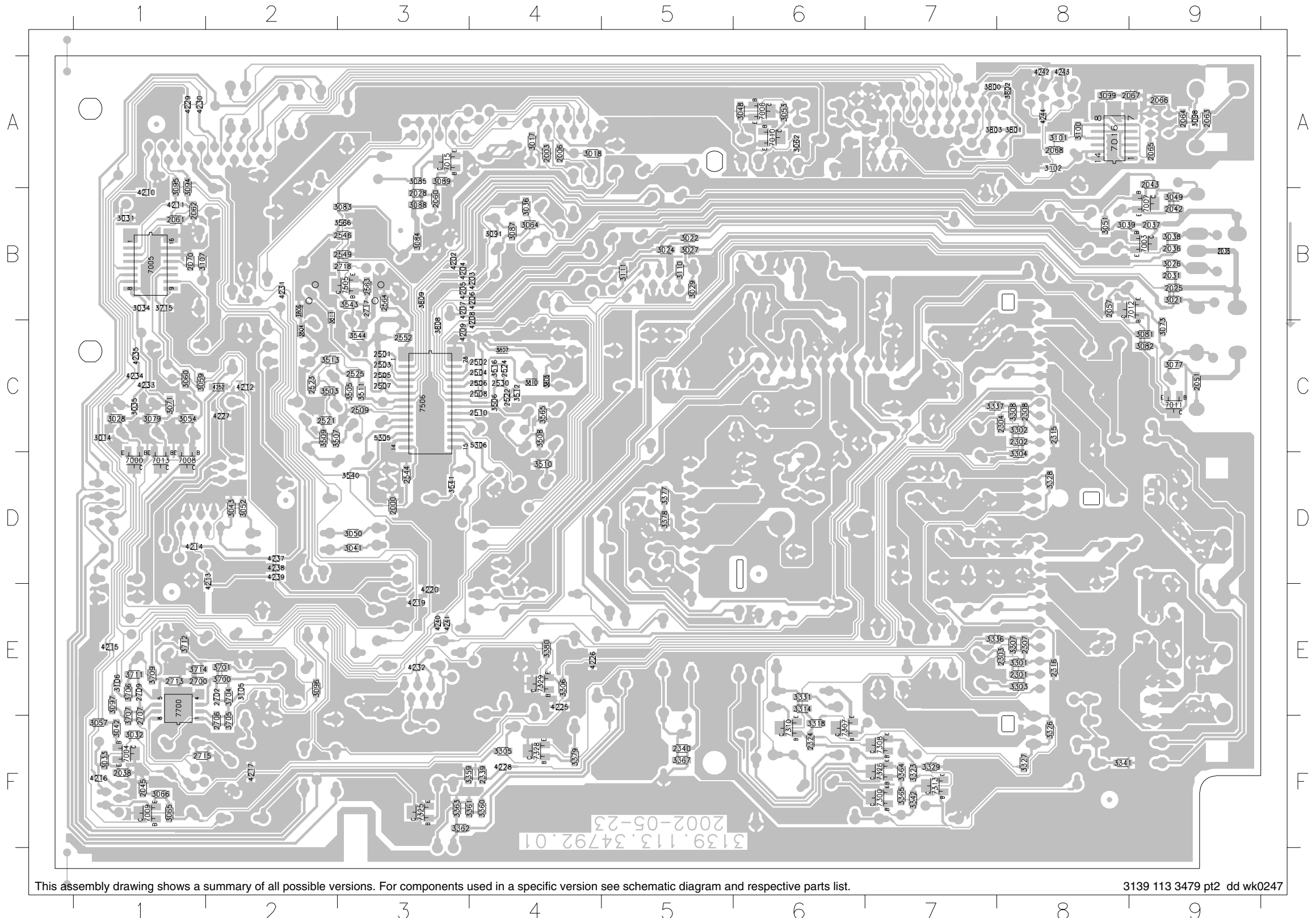

This assembly drawing shows a summary of all possible versions. For components used in a specific version see schematic diagram and respective parts list. 3139 113 3479 pt2 dd wk0247

COMBI BOARD - COMPONENT LAYOUT

0300 D4	1026 A9	2014 B1	2056 C6	2314 C3	2512 C6	2708 E8	3366 F5	6303 E1	6331 D5	9210 B4	9223 A7	9237 B8	9251 C4	9266 D3	9280 F7	9297 D7	9314 E6
1001 B1	1030 A3	2015 B6	2058 C9	2317 E1	2513 C7	2714 F8	3713 E8	6304 D4	6332 F4	9211 B4	9224 E7	9238 B8	9252 C4	9267 E3	9281 E6	9299 D8	9315 E8
1002 A4	1031 A2	2017 B7	2069 A2	2318 D1	2514 C7	2716 E9	5001 A2	6306 F3	7301 E2	9212 B4	9225 A7	9240 B8	9254 C3	9268 E3	9282 D7	9300 D8	9316 E6
1004 C1	1032 A2	2020 B1	2080 B5	2319 F1	2515 C8	3015 A3	5300 D2	6307 F3	7302 C2	9213 B4	9226 A3	9241 C8	9255 C3	9269 E3	9285 D7	9301 E8	
1006 A1	1300 C3	2021 C8	2081 B5	2320 D1	2516 C6	3046 A4	5301 E2	6308 C3	7304 D2	9214 A4	9227 F8	9242 C6	9256 C3	9270 E3	9286 D7	9302 E9	
1013 A6	1301 D3	2023 B6	2300 F4	2321 E1	2517 D7	3300 E6	5302 C2	6311 D5	7309 F2	9215 A3	9228 A8	9243 C8	9257 C4	9271 E3	9287 D7	9303 D9	
1014 F9	1302 D5	2027 B5	2305 E2	2322 D1	2518 D6	3309 D2	5303 F2	6315 F3	9201 B2	9216 B5	9229 A8	9244 C7	9258 D3	9272 E4	9288 E7	9304 E9	
1015 D9	1304 D9	2032 C9	2306 D3	2333 E5	2545 D7	3310 C2	5700 F8	6323 F4	9202 B2	9217 A6	9231 C8	9245 C5	9259 D3	9273 E5	9289 E7	9305 F8	
1018 A4	1307 E1	2033 F9	2309 D2	2334 C3	2547 C6	3311 E2	6002 B8	6324 F4	9203 A3	9218 B6	9232 A9	9246 C6	9260 C5	9274 E5	9290 E7	9307 F8	
1020 B5	1314 C4	2046 F9	2310 C3	2335 D3	2550 C7	3312 D1	6003 A4	6325 D6	9204 E8	9219 B6	9233 B8	9247 C5	9261 C4	9275 E6	9291 E7	9308 E8	
1021 C5	1315 E7	2048 B8	2311 D1	2336 C4	2551 B7	3315 E4	6300 F1	6326 F7	9205 B7	9220 B6	9234 B9	9248 A8	9262 D4	9276 E5	9293 F7	9311 E8	
1023 D9	1316 B5	2052 C1	2312 C1	2341 D6	2560 D7	3340 F2	6301 F1	6327 F7	9207 A3	9221 B6	9235 C9	9249 A8	9264 D4	9277 E5	9294 E7	9312 B3	
1025 A7	2011 B6	2055 B1	2313 E3	2511 C8	2701 E8	3353 E4	6302 F1	6328 F5	9209 B4	9222 B7	9236 E5	9250 B4	9265 D3	9278 E6	9295 D8	9313 A8	

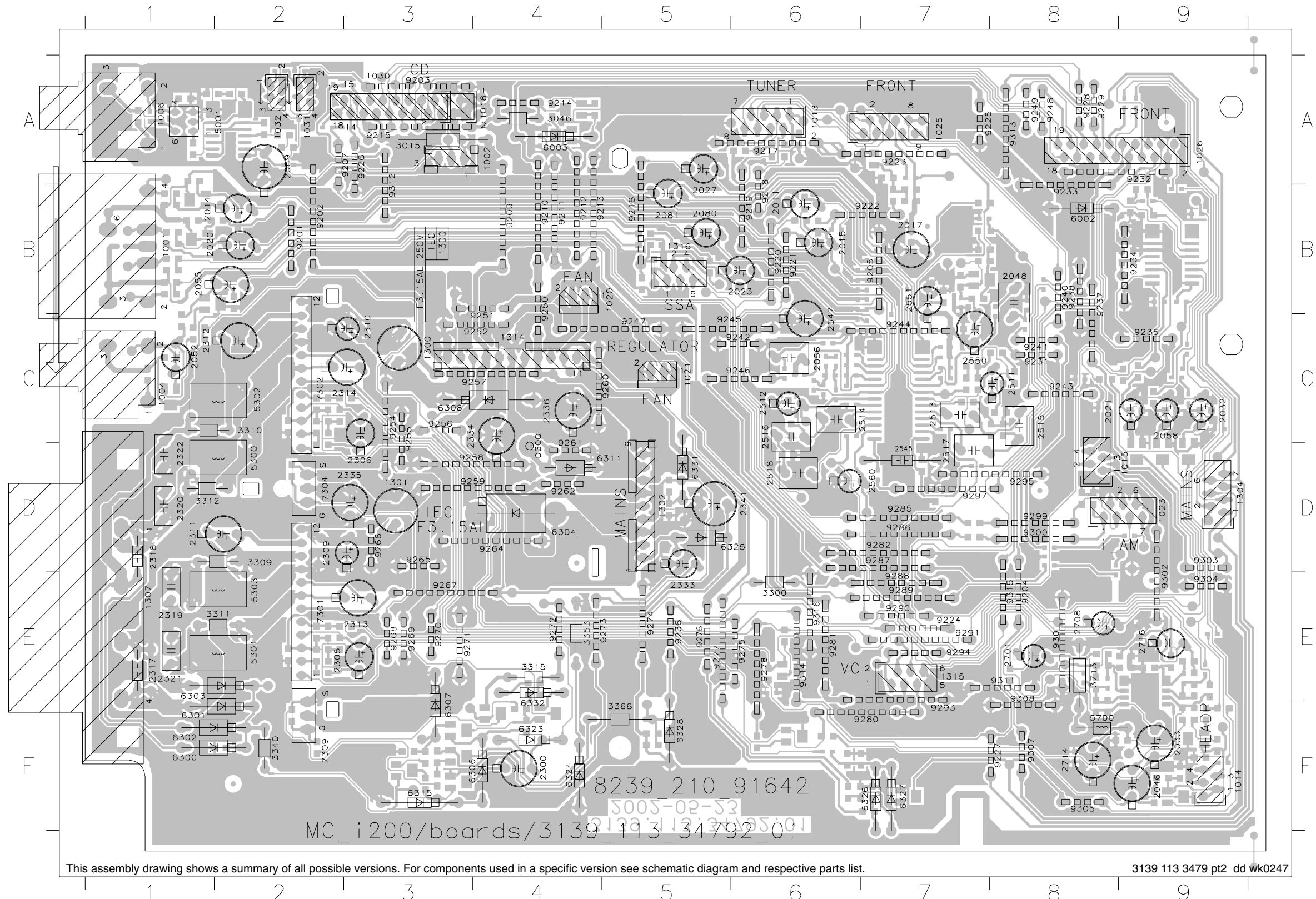

This assembly drawing shows a summary of all possible versions. For components used in a specific version see schematic diagram and respective parts list. 3139 113 3479 pt2 dd wk0247

COMBI CIRCUIT - POWER AMPLIFIER PART

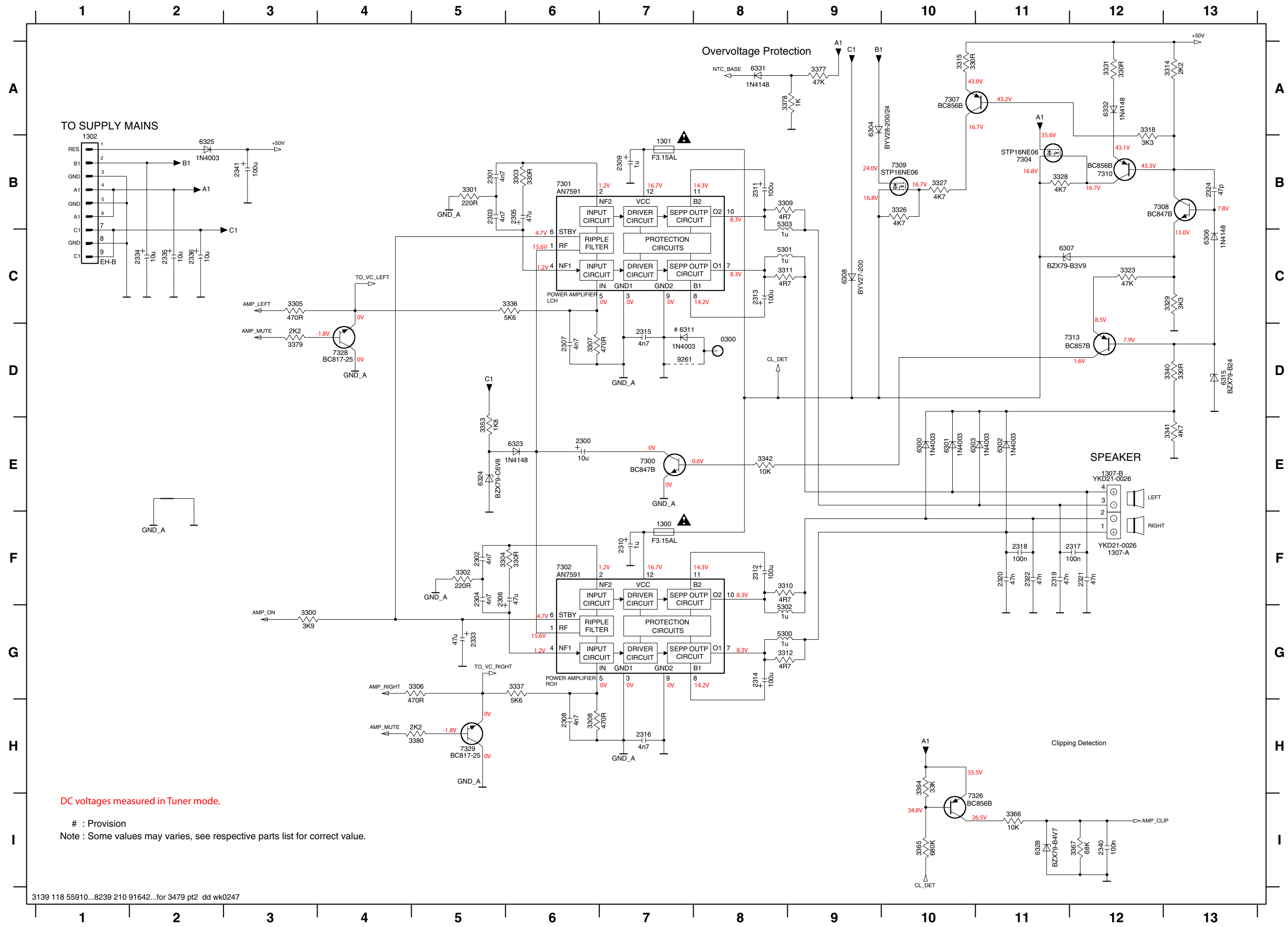

TO SUPPLY MAINS

Overvoltage Protection

SPEAKER

Clipping Detection

DC voltages measured in Tuner mode.

: Provision
Note : Some values may varies, see respective parts list for correct value.

- 0300 D8
- 1300 F7
- 1301 B7
- 1302 B1
- 1307-A F12
- 2300 E6
- 1307-B E12
- 2300 E6
- 2301 B5
- 2302 F5
- 2303 B5
- 2304 F5
- 2305 B6
- 2306 F5
- 2307 D6
- 2308 H6
- 2309 B7
- 2310 F7
- 2311 B8
- 2312 F8
- 2313 C8
- 2314 G8
- 2315 D7
- 2316 H7
- 2317 F12
- 2318 F11
- 2319 F11
- 2320 F11
- 2321 F12
- 2322 F11
- 2324 B13
- 2333 G5
- 2334 C2
- 2335 C2
- 2336 C2
- 2340 I12
- 2341 B3
- 3300 G3
- 3301 B5
- 3302 F5
- 3303 B6
- 3304 F5
- 3305 C3
- 3306 G5
- 3307 D6
- 3308 H6
- 3309 B8
- 3310 F8
- 3311 C8
- 3312 G8
- 3314 A13
- 3315 A10
- 3318 A12
- 3323 C12
- 3326 B10
- 3327 B10
- 3328 B11
- 3329 C13
- 3331 A12
- 3336 C6
- 3337 G6
- 3340 D13
- 3341 E13
- 3342 E8
- 3353 E5
- 3364 H10
- 3365 I10
- 3366 I11
- 3367 I12
- 3377 A9
- 3378 A8
- 3379 D3
- 3380 H5
- 5300 G8
- 5301 C8
- 5302 G8
- 5303 B8
- 6300 E8
- 6301 E10
- 6302 E11
- 6303 E10
- 6304 A9
- 6306 C13
- 6307 C11
- 6308 C9
- 6311 D7
- 6315 D13
- 6323 E6
- 6324 E5
- 6325 B2
- 6328 I11
- 6331 A8
- 6332 A12
- 7300 E7
- 7301 B6
- 7302 F6
- 7304 B11
- 7307 A10
- 7308 B13
- 7309 B10
- 7310 B12
- 7313 D12
- 7326 I10
- 7328 D4
- 7329 H5
- 9261 D7

COMBI CIRCUIT - SOURCE SELECT & SOUND CONTROL PART

2501 F3	2504 F5	2507 F4	2510 F7	2513 C7	2516 F8	2521 C9	2524 G10	2544 E9	2547 C5	2551 A4	2563 A3	2718 A3	3506 G10	3509 C8	3512 G5	3540 D10	3544 B3	3808 E4	3811 D3	7505 A3
2502 F5	2505 F3	2508 F4	2511 B6	2514 F7	2517 B8	2522 G9	2525 B10	2545 E9	2549 A2	2552 D5	2564 A3	3503 B6	3507 C8	3510 F8	3513 B10	3541 E10	3565 H10	3809 D4	5305 D10	7506 C5
2503 F3	2506 F4	2509 C7	2512 G10	2515 B8	2518 F8	2523 B10	2530 F10	2546 E5	2550 B2	2560 F12	2717 B3	3505 B10	3508 F8	3511 B6	3516 G10	3543 B2	3566 D4	3810 E3	5306 E10	

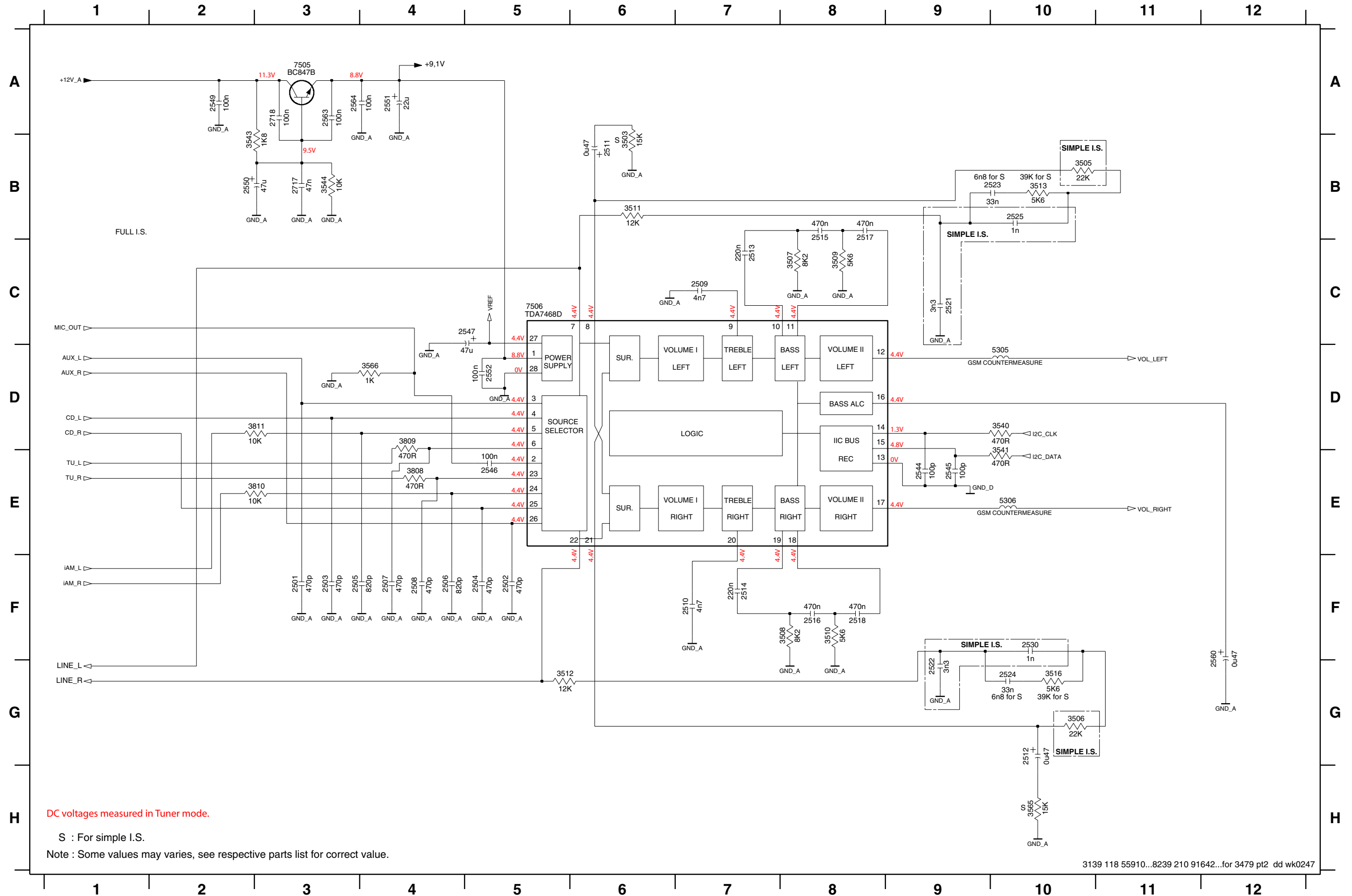

COMBI CIRCUIT - HEADPHONE AMPLIFIER PART

1014 E9	2017 A2	2038 E8	2060 B1	2700 D4	2707 E4	2714 F2	3028 C8	3034 F13	3048 E11	3062 F11	3084 A2	3089 B1	3096 E5	3107 D11	3705 E4	3711 F4	3715 F12	6003 E11	7006 E10	7700-A D4
1015 B10	2028 B2	2045 F8	2061 D11	2701 D3	2708 F3	2715 G2	3031 F13	3035 D8	3053 F10	3065 G7	3085 B2	3091 B1	3097 F5	3700 D4	3706 E3	3712 E2	4252 F12	7000 C7	7009 F7	7700-B F4
1315 A6	2032 C7	2046 F6	2062 D11	2702 D4	2709 F4	2716 E2	3032 D7	3042 E7	3057 F7	3066 G7	3087 B1	3094 C11	3105 D3	3701 D3	3707 E4	3713 G2	5700 G2	7004 E7	7010 F10	9214 E10
1316 A8	2033 D6	2055 E5	2070 D11	2706 D4	2713 F4	3014 F9	3033 D7	3046 E10	3059 F11	3083 A2	3088 B1	3095 C11	3106 F3	3704 E3	3709 F3	3714 E2	6002 D10	7005 C12	7015 B2	

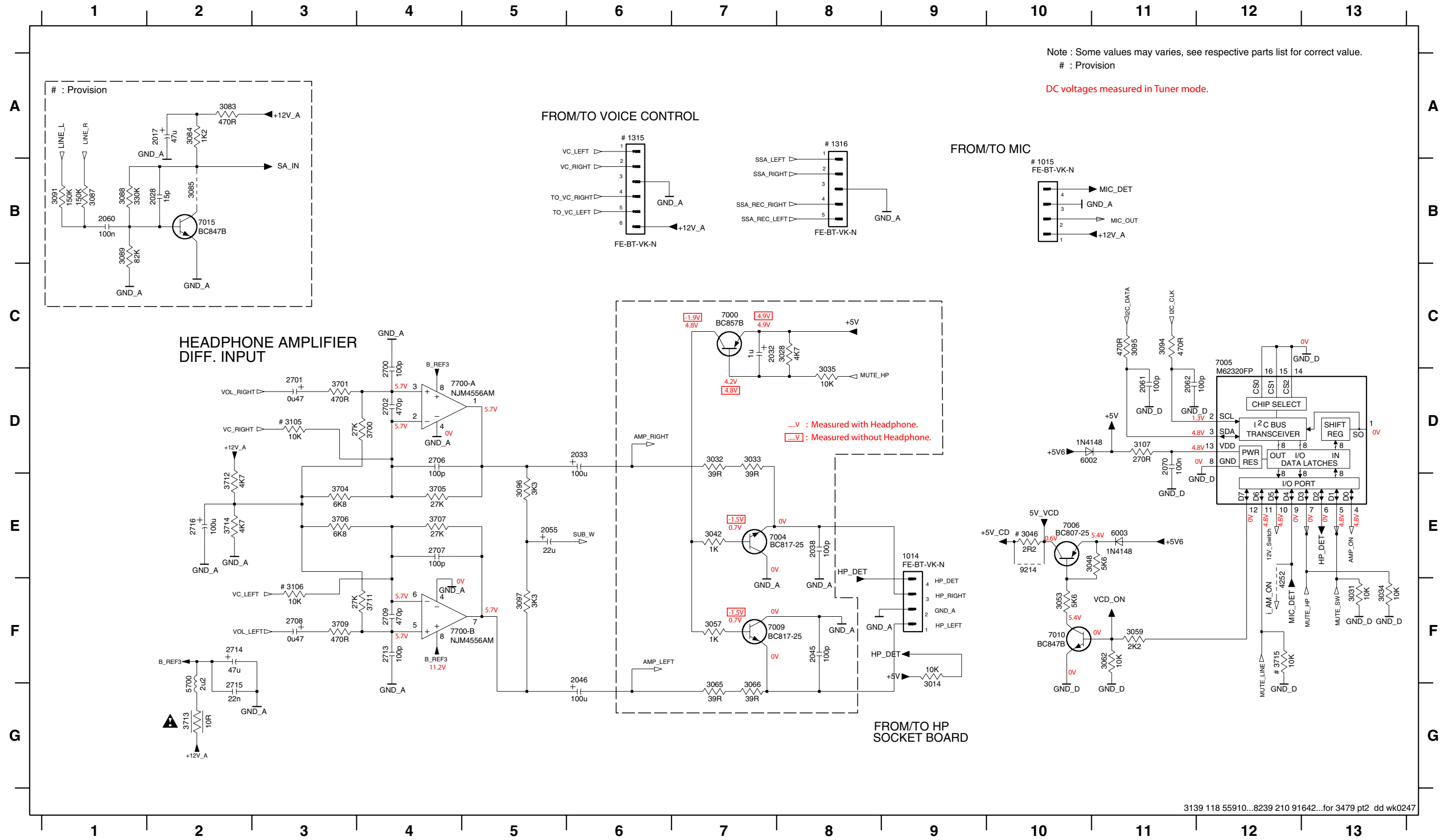

Note : Some values may varies, see respective parts list for correct value.
: Provision

DC voltages measured in Tuner mode.

...v : Measured with Headphone.
[]v : Measured without Headphone.

COMBI CIRCUIT - CONNECTOR PART

1001-A F1	1006 A1	1021 H7	1030 B12	1314 G8	2011 C4	2021 D4	2031 F2	2042 D2	2052 G1	2063 B1	2067 B3	2081 D14	3018 G6	3026 F2	3038 C2	3049 C2	3054 D4	3073 G2	3082 H3	3101 A4	3359 D10	3363 D10	3803 D14	3807 D6	7003 C3	7012 H2	9227 G10
1001-B D1	1013 G4	1023 C8	1031 A12	2000 F5	2014 D3	2023 E3	2035 C1	2043 D3	2056 D6	2064 A2	2068 A5	2339 D9	3021 E1	3027 F2	3039 C3	3050 C5	3060 D4	3077 H1	3098 A1	3102 A2	3360 C10	3800 C14	3804 E6	5001 A2	7007 C3	7013 H4	
1002 A5	1018 B11	1025 F7	1032 A14	2003 G6	2015 D4	2025 E2	2036 C2	2048 E6	2057 H2	2065 A3	2069 A2	3015 C13	3022 E2	3029 F3	3041 C5	3051 D3	3064 D4	3079 H4	3099 A3	3110 E2	3361 D10	3801 C14	3805 D6	5002 A2	7008 D3	7016 A3	
1004 H1	1020 H8	1026 E14	1304 E10	2006 G6	2020 B3	2027 F3	2037 C3	2051 G1	2058 H4	2066 B2	2080 D13	3017 G6	3024 E3	3036 B4	3043 C5	3052 D5	3071 H5	3081 H3	3100 A4	3111 E2	3362 C10	3802 D14	3806 E6	5001 A2	7011 H2	7325 D9	

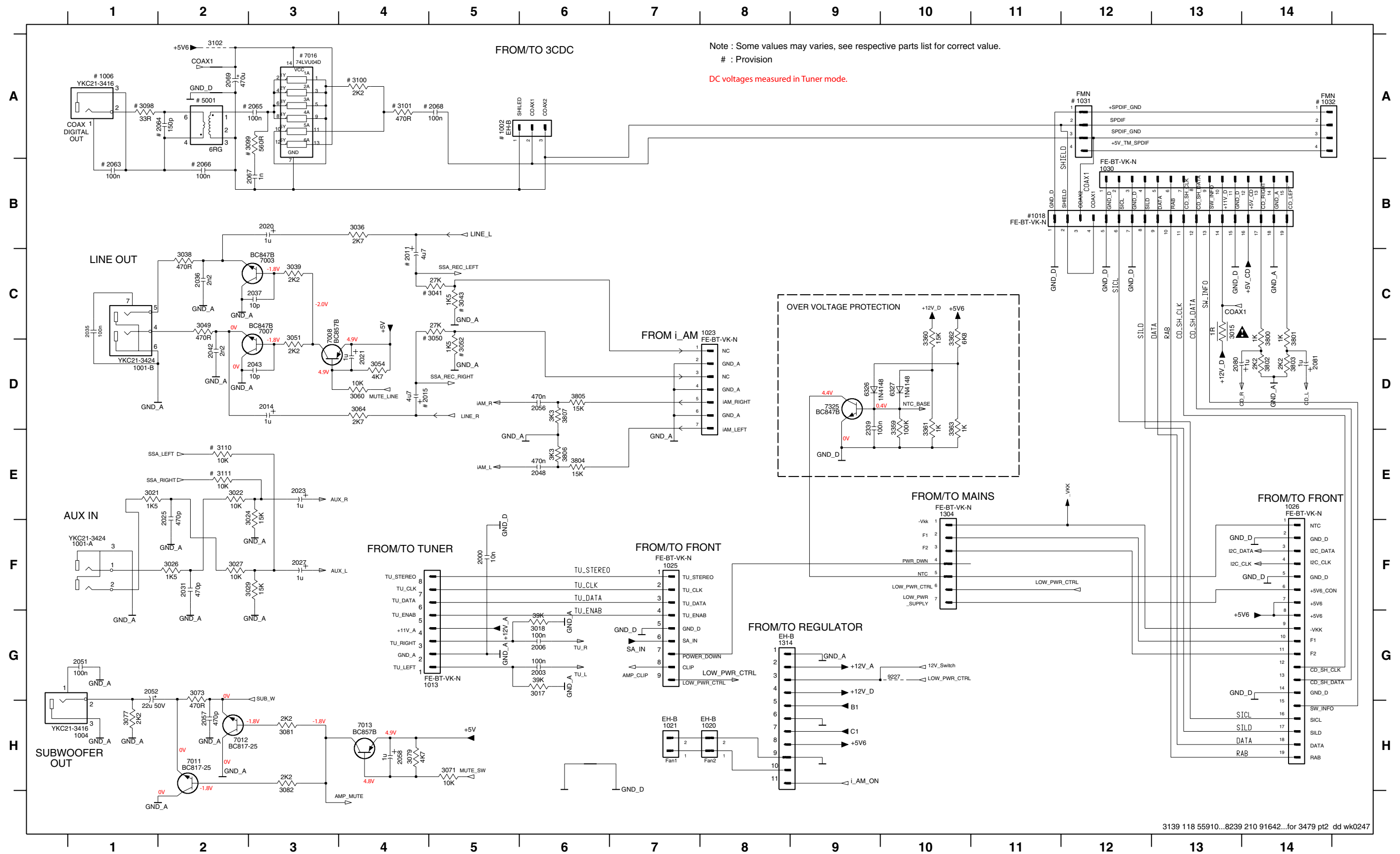

MECHANICAL PARTS LIST

4822 492 11735 SPRING TRANS

ELECTRICAL PARTS LIST - REGULATOR BOARD**MISCELLANEOUS**1171 4822 071 52502 Δ Fuse RAD LT 2,5A**CAPACITORS**

2400 4822 124 22652 2,2uF 20% 50V
 2402 4822 124 80231 47uF 20% 16V
 2405 4822 124 11947 10uF 20% 16V
 2406 4822 124 23052 100uF 20% 16V
 2407 4822 124 23052 100uF 20% 16V
 2411 4822 124 80231 47uF 20% 16V
 2412 4822 124 22651 1uF 20% 50V
 2413 4822 124 11947 10uF 20% 16V
 2415 4822 124 11947 10uF 20% 16V
 2416 2022 020 00625 220uF 20% 16V

RESISTORS

3403 4822 050 11002 1k 1% 0,4W
 3404 4822 116 52256 2k2 5% 0,5W
 3405 4822 116 83876 270R 5% 0,5W
 3406 4822 050 11002 1k 1% 0,4W
 3407 4822 116 52244 15k 5% 0,5W
 3411 4822 116 83883 470R 5% 0,5W
 3415 4822 116 52199 68R 5% 0,5W
 3416 4822 116 52206 120R 5% 0,5W
 3417 4822 116 52206 120R 5% 0,5W
 3418 4822 117 12063 Δ NTC DC 5W 10k 5%
 3419 4822 116 52219 330R 5% 0,5W
 3420 4822 050 11002 1k 1% 0,4W
 3421 4822 052 10568 Δ 5R6 5% 0,33W
 3423 4822 116 52257 22k 5% 0,5W
 3424 4822 116 52285 470k 5% 0,5W
 3425 4822 116 52256 2k2 5% 0,5W
 3426 4822 116 52234 100k 5% 0,5W
 3427 4822 116 52175 100R 5% 0,5W
 3428 4822 116 83868 150R 5% 0,5W
 3431 4822 116 52175 100R 5% 0,5W
 3432 4822 116 52207 1k2 5% 0,5W
 3433 4822 116 52243 1k5 5% 0,5W
 3434 4822 116 52206 120R 5% 0,5W
 3435 4822 116 83868 150R 5% 0,5W
 3440 4822 116 52226 560R 5% 0,5W
 3441 4822 050 21003 10k 1% 0,6W

DIODES

6400 4822 130 30621 1N4148
 6401 4822 130 30621 1N4148
 6405 4822 130 61219 BZX79-B10

6406 4822 130 31981 BZX79-C3V9
 6407 4822 130 34174 BZX79-B4V7
 6411 4822 130 30621 1N4148
 6412 4822 130 30621 1N4148
 6413 3198 010 53980 BZX79-B3V9

TRANSISTORS & INTEGRATED CIRCUITS

7401 4822 130 40959 BC547B
 7402 4822 130 44568 BC557B
 7403 9322 139 23687 BDX53BFP
 7404 4822 130 44568 BC557B
 7408 4822 130 40959 BC547B
 7409 4822 130 41246 BC327-25
 7410 5322 130 62071 BDX53B
 7411 4822 130 40959 BC547B
 7412 4822 130 40959 BC547B
 7413 4822 130 10847 BDW94C
 7414 4822 130 40959 BC547B
 7415 4822 130 40959 BC547B

Note : Only the parts mentioned in this list are normal service spare parts.

ELECTRICAL PARTS LIST - COMBI BOARD**MISCELLANEOUS**

1001 4822 267 31823 Cinch Socket-Line out & Aux in
 1004 4822 267 31729 Cinch Socket - Subwoofer out
 1013 4822 265 11515 Flex Connector 8P
 1014 4822 267 10733 Flex Connector 4P
 1023 4822 267 10953 Flex Connector 7P
 1025 2422 025 14518 Flex Connector 9P
 1026 4822 265 11553 Flex Connector 19P
 1030 4822 265 10981 Flex Connector 15P
 1300 4822 252 11225 Δ Fuse RAD LF 3,15A
 1301 4822 252 11225 Δ Fuse RAD LF 3,15A
 1304 4822 267 10953 Flex Connector 7P
 1307 4822 267 31176 Speaker Terminal

CAPACITORS

2000 5322 126 11583 10nF 10% 50V
 2003 2238 586 59812 100nF 50V
 2006 2238 586 59812 100nF 50V
 2014 2022 020 00734 1uF 20% 50V
 2020 2022 020 00734 1uF 20% 50V
 2021 4822 124 22651 1uF 20% 50V
 2023 2022 020 00734 1uF 20% 50V
 2025 4822 126 13881 470pF 5% 50V
 2027 2022 020 00734 1uF 20% 50V
 2031 4822 126 13881 470pF 5% 50V
 2032 4822 124 22651 1uF 20% 50V
 2033 4822 124 23052 100uF 20% 16V
 2035 2238 586 59812 100nF 50V
 2036 4822 126 14238 2,2nF 50V
 2037 4822 122 33741 10pF 10% 50V
 2038 2020 552 94427 100pF 5% 50V
 2042 4822 126 14238 2,2nF 50V
 2043 4822 122 33741 10pF 10% 50V
 2045 2020 552 94427 100pF 5% 50V
 2046 4822 124 23052 100uF 20% 16V
 2048 4822 121 51252 470nF 5% 63V
 2051 2238 586 59812 100nF 50V
 2052 4822 124 81151 22uF 50V
 2055 4822 124 40764 22uF 100 V
 2056 4822 121 51252 470nF 5% 63V
 2057 4822 126 13881 470pF 5% 50V
 2058 4822 124 22651 1uF 20% 50V
 2061 2020 552 94427 100pF 5% 50V
 2062 2020 552 94427 100pF 5% 50V
 2069 4822 124 80791 470uF 20% 16V
 2070 2238 586 59812 100nF 50V
 2080 2022 020 00734 1uF 20% 50V
 2081 2022 020 00734 1uF 20% 50V
 2300 4822 124 12255 10uF 20% 50V
 2301 4822 126 13193 4,7nF 10% 63V
 2302 4822 126 13193 4,7nF 10% 63V
 2303 4822 126 13193 4,7nF 10% 63V
 2304 4822 126 13193 4,7nF 10% 63V

2305 4822 124 40433 47uF 20% 25V
 2306 4822 124 40433 47uF 20% 25V
 2307 4822 126 13193 4,7nF 10% 63V
 2308 4822 126 13193 4,7nF 10% 63V
 2309 4822 124 22651 1uF 20% 50V
 2310 4822 124 22651 1uF 20% 50V
 2311 4822 124 40207 100uF 20% 25V
 2312 4822 124 40207 100uF 20% 25V
 2313 4822 124 40207 100uF 20% 25V
 2314 4822 124 40207 100uF 20% 25V
 2315 4822 126 13193 4,7nF 10% 63V
 2316 4822 126 13193 4,7nF 10% 63V
 2317 2020 561 90365 100nF +80/-20% 50V
 2318 2020 561 90365 100nF +80/-20% 50V
 2319 4822 121 43526 47nF 5% 250V
 2320 4822 121 43526 47nF 5% 250V
 2321 4822 121 43526 47nF 5% 250V
 2322 4822 121 43526 47nF 5% 250V
 2324 4822 126 11785 47pF 5% 50V
 2333 4822 124 40433 47uF 20% 25V
 2334 4822 124 12255 10uF 20% 50V
 2335 4822 124 12255 10uF 20% 50V
 2336 4822 124 12255 10uF 20% 50V
 2339 2238 586 59812 100nF 50V
 2340 2238 586 59812 100nF 50V
 2341 2020 012 93664 100uF 20% 50V
 2501 4822 126 13881 470pF 5% 50V
 2502 4822 126 13881 470pF 5% 50V
 2503 4822 126 13881 470pF 5% 50V
 2504 4822 126 13881 470pF 5% 50V
 2505 3198 016 38210 820pF 25V
 2506 3198 016 38210 820pF 25V
 2507 4822 126 13881 470pF 5% 50V
 2508 4822 126 13881 470pF 5% 50V
 2509 4822 126 13193 4,7nF 10% 63V
 2510 4822 126 13193 4,7nF 10% 63V
 2511 5322 124 41948 470nF 20% 50V
 2512 5322 124 41948 470nF 20% 50V
 2513 4822 121 42408 220nF 5% 63V
 2514 4822 121 42408 220nF 5% 63V
 2515 4822 121 51252 470nF 5% 63V
 2516 4822 121 51252 470nF 5% 63V
 2517 4822 121 51252 470nF 5% 63V
 2518 4822 121 51252 470nF 5% 63V
 2521 5322 126 11579 3,3nF 10% 63V
 2522 5322 126 11579 3,3nF 10% 63V
 2523 4822 126 14549 33nF 16V
 2524 4822 126 14549 33nF 16V
 2525 3198 016 31020 1nF 25V
 2530 3198 016 31020 1nF 25V
 2544 2020 552 94427 100pF 5% 50V
 2545 4822 122 33195 100pF 10% 50V

ELECTRICAL PARTS LIST - COMBI BOARD

CAPACITORS

2546	4822 126 14585	100nF 10% 50V
2547	4822 124 81286	47uF 20% 16V
2549	2238 586 59812	100nF 50V
2550	4822 124 40433	47uF 20% 25V
2551	4822 124 81151	22uF 50V
2552	2238 586 59812	100nF 50V
2560	5322 124 41948	470nF 20% 50V
2563	2238 586 59812	100nF 50V
2564	2238 586 59812	100nF 50V
2700	2020 552 94427	100pF 5% 50V
2701	5322 124 41948	470nF 20% 50V
2702	4822 126 13881	470pF 5% 50V
2706	2020 552 94427	100pF 5% 50V
2707	2020 552 94427	100pF 5% 50V
2708	5322 124 41948	470nF 20% 50V
2709	4822 126 13881	470pF 5% 50V
2713	2020 552 94427	100pF 5% 50V
2714	4822 124 81286	47uF 20% 16V
2715	3198 017 42230	22nF 50V
2716	4822 124 23052	100uF 20% 16V
2717	3198 017 34730	47nF 16V
2718	2238 586 59812	100nF 50V

RESISTORS

3014	4822 051 30103	10k 5% 0,062W
3015	4822 052 10108	△ 1R 5% 0,33W
3017	4822 051 30393	39k 5% 0,062W
3018	4822 051 30393	39k 5% 0,062W
3021	4822 051 30152	1k5 5% 0,062W
3022	4822 051 30103	10k 5% 0,062W
3024	4822 051 30153	15k 5% 0,062W
3026	4822 051 30152	1k5 5% 0,062W
3027	4822 051 30103	10k 5% 0,062W
3028	4822 051 30472	4k7 5% 0,062W
3029	4822 051 30153	15k 5% 0,062W
3031	4822 051 30103	10k 5% 0,062W
3032	2120 108 91909	RST SM 0603 ERJ3G 39R 5%
3033	2120 108 91909	RST SM 0603 ERJ3G 39R 5%
3034	4822 051 30103	10k 5% 0,062W
3035	4822 051 30103	10k 5% 0,062W
3036	4822 051 30272	2k7 5% 0,062W
3038	4822 051 30471	470R 5% 0,062W
3039	4822 051 30222	2k2 5% 0,062W
3042	4822 051 30102	1k 5% 0,062W
3046	4822 116 81154	2R2 5% 0,5W
3048	4822 051 30562	5k6 5% 0,063W
3049	4822 051 30471	470R 5% 0,062W
3051	4822 051 30222	2k2 5% 0,062W
3053	4822 051 30562	5k6 5% 0,063W
3054	4822 051 30472	4k7 5% 0,062W
3057	4822 051 30102	1k 5% 0,062W
3059	4822 051 30222	2k2 5% 0,062W

3060	4822 051 30103	10k 5% 0,062W
3062	4822 051 30103	10k 5% 0,062W
3064	4822 051 30272	2k7 5% 0,062W
3065	2120 108 91909	RST SM 0603 ERJ3G 39R 5%
3066	2120 108 91909	RST SM 0603 ERJ3G 39R 5%
3071	4822 051 30103	10k 5% 0,062W
3073	4822 051 30471	470R 5% 0,062W
3077	4822 051 30222	2k2 5% 0,062W
3079	4822 051 30472	4k7 5% 0,062W
3081	4822 051 30222	2k2 5% 0,062W
3082	4822 051 30222	2k2 5% 0,062W
3094	4822 051 30471	470R 5% 0,062W
3095	4822 051 30471	470R 5% 0,062W
3096	4822 051 30332	3k3 5% 0,062W
3097	4822 051 30332	3k3 5% 0,062W
3102	4822 051 30008	OR Jumper 0603
3107	4822 051 30271	270R 5% 0,062W
3300	4822 116 52276	3k9 5% 0,5W
3301	4822 051 30221	220R 5% 0,062W
3302	4822 051 30221	220R 5% 0,062W
3303	4822 051 30331	330R 5% 0,062W
3304	4822 051 30331	330R 5% 0,062W
3305	4822 051 30471	470R 5% 0,062W
3306	4822 051 30471	470R 5% 0,062W
3307	4822 051 30471	470R 5% 0,062W
3308	4822 051 30471	470R 5% 0,062W
3309	4822 050 24708	4R7 1% 0,6W
3310	4822 050 24708	4R7 1% 0,6W
3311	4822 050 24708	4R7 1% 0,6W
3312	4822 050 24708	4R7 1% 0,6W
3314	4822 051 30222	2k2 5% 0,062W
3315	4822 116 52219	330R 5% 0,5W
3318	4822 051 30332	3k3 5% 0,062W
3323	4822 117 12925	47k 1% 0,063W
3326	4822 051 30472	4k7 5% 0,062W
3327	4822 051 30472	4k7 5% 0,062W
3328	4822 051 30472	4k7 5% 0,062W
3329	4822 051 30332	3k3 5% 0,062W
3331	4822 051 30331	330R 5% 0,062W
3336	4822 051 30562	5k6 5% 0,063W
3337	4822 051 30562	5k6 5% 0,063W
3340	4822 116 52219	330R 5% 0,5W
3341	4822 051 30472	4k7 5% 0,062W
3342	4822 051 30103	10k 5% 0,062W
3353	4822 116 52249	1k8 5% 0,5W
3359	4822 117 13632	100k 1% 0,62W
3360	4822 051 30153	15k 5% 0,062W
3361	4822 051 30102	1k 5% 0,062W
3362	4822 051 30682	6k8 5% 0,062W
3363	4822 051 30102	1k 5% 0,062W
3364	4822 051 30333	33k 5% 0,062W
3365	4822 051 30684	680k 5% 0,062W

ELECTRICAL PARTS LIST - COMBI BOARD

3366	4822 050 21003	10k 1% 0,6W
3367	4822 051 30683	68k 5% 0,062W
3377	4822 117 12925	47k 1% 0,063W
3378	4822 051 30102	1k 5% 0,062W
3379	4822 051 30222	2k2 5% 0,062W
3380	4822 051 30222	2k2 5% 0,062W
3503	4822 051 30153	15k 5% 0,062W
3505	4822 051 30223	22k 5% 0,062W
3506	4822 051 30223	22k 5% 0,062W
3507	4822 117 12902	8k2 1% 0,063W
3508	4822 117 12902	8k2 1% 0,063W
3509	4822 051 30562	5k6 5% 0,063W
3510	4822 051 30562	5k6 5% 0,063W
3511	4822 051 30123	12k 5% 0,062W
3512	4822 051 30123	12k 5% 0,062W
3513	4822 051 30562	5k6 5% 0,063W
3516	4822 051 30562	5k6 5% 0,063W
3540	4822 051 30471	470R 5% 0,062W
3541	4822 051 30471	470R 5% 0,062W
3543	4822 117 12903	1k8 1% 0,063W
3544	4822 051 30103	10k 5% 0,062W
3565	4822 051 30153	15k 5% 0,062W
3566	4822 051 30102	1k 5% 0,062W
3700	4822 051 30273	27k 5% 0,062W
3701	4822 051 30471	470R 5% 0,062W
3704	4822 051 30682	6k8 5% 0,062W
3705	4822 051 30273	27k 5% 0,062W
3706	4822 051 30682	6k8 5% 0,062W
3707	4822 051 30273	27k 5% 0,062W
3709	4822 051 30471	470R 5% 0,062W
3711	4822 051 30273	27k 5% 0,062W
3712	4822 051 30472	4k7 5% 0,062W
3713	4822 052 10109	△ 10R 5% 0,33W
3714	4822 051 30472	4k7 5% 0,062W
3800	4822 051 30102	1k 5% 0,062W
3801	4822 051 30102	1k 5% 0,062W
3802	4822 051 30222	2k2 5% 0,062W
3803	4822 051 30222	2k2 5% 0,062W
3804	4822 051 30153	15k 5% 0,062W
3805	4822 051 30153	15k 5% 0,062W
3806	4822 051 30472	4k7 5% 0,062W
3807	4822 051 30472	4k7 5% 0,062W
3808	4822 051 30471	470R 5% 0,062W
3809	4822 051 30471	470R 5% 0,062W
3810	4822 051 30103	10k 5% 0,062W
3811	4822 051 30103	10k 5% 0,062W
4202	4822 051 30008	OR Jumper 0603
4203	4822 051 30008	OR Jumper 0603
4204	4822 051 30008	OR Jumper 0603
4205	4822 051 30008	OR Jumper 0603
4206	4822 051 30008	OR Jumper 0603
4207	4822 051 30008	OR Jumper 0603

4208	4822 051 30008	OR Jumper 0603
4209	4822 051 30008	OR Jumper 0603
4210	4822 051 30008	OR Jumper 0603
4211	4822 051 30008	OR Jumper 0603
4212	4822 051 30008	OR Jumper 0603
4213	4822 051 30008	OR Jumper 0603
4214	4822 051 30008	OR Jumper 0603
4215	4822 051 30008	OR Jumper 0603
4216	4822 051 30008	OR Jumper 0603
4217	4822 051 30008	OR Jumper 0603
4219	4822 051 30008	OR Jumper 0603
4220	4822 051 30008	OR Jumper 0603
4225	4822 051 30008	OR Jumper 0603
4226	4822 051 30008	OR Jumper 0603
4227	4822 051 30008	OR Jumper 0603
4228	4822 051 30008	OR Jumper 0603
4231	4822 051 30008	OR Jumper 0603
4232	4822 051 30008	OR Jumper 0603
4233	4822 051 30008	OR Jumper 0603
4234	4822 051 30008	OR Jumper 0603
4235	4822 051 30008	OR Jumper 0603
4237	4822 051 30008	OR Jumper 0603
4238	4822 051 30008	OR Jumper 0603
4239	4822 051 30008	OR Jumper 0603
4240	4822 051 30008	OR Jumper 0603
4241	4822 051 30008	OR Jumper 0603
4252	4822 051 20008	OR Jumper 0805

COILS & FILTERS

5300	4822 157 62255	Coil 18,5 Turns
5301	4822 157 62255	Coil 18,5 Turns
5302	4822 157 62255	Coil 18,5 Turns
5303	4822 157 62255	Coil 18,5 Turns
5305	2422 549 44607	IND FXD EMI 100MHz 600R
5306	2422 549 44607	IND FXD EMI 100MHz 600R
5700	4822 157 62552	Coil 2,2uH 5%

DIODES

6002	4822 130 30621	1N4148
6003	4822 130 30621	1N4148
6300	4822 130 31878	1N4003G
6301	4822 130 31878	1N4003G
6302	4822 130 31878	1N4003G
6303	4822 130 31878	1N4003G
6304	9340 550 66112	BYV28-200/24
6306	4822 130 30621	1N4148
6307	3198 010 53980	BZX79-B3V9
6308	5322 130 31938	BYV27-200
6315	4822 130 34398	BZX79-B24
6323	4822 130 30621	1N4148
6324	4822 130 34278	BZX79-C6V8
6325	4822 130 31878	1N4003G

ELECTRICAL PARTS LIST - COMBI BOARD

DIODES

6326	4822 130 30621	1N4148
6327	4822 130 30621	1N4148
6328	4822 130 34174	BZX79-B4V7
6331	4822 130 30621	1N4148
6332	4822 130 30621	1N4148

TRANSISTORS & INTEGRATED CIRCUITS

7000	4822 130 60373	BC857B
7003	5322 130 60159	BC847B
7004	4822 130 42804	BC817-25
7005	4822 209 17345	M62320FP
7006	5322 130 60845	BC807-25
7007	5322 130 60159	BC847B
7008	4822 130 60373	BC857B
7009	4822 130 42804	BC817-25
7010	5322 130 60159	BC847B
7011	4822 130 42804	BC817-25
7012	4822 130 42804	BC817-25
7013	4822 130 60373	BC857B
7300	5322 130 60159	BC847B
7301	9322 153 02682	AN7591
7302	9322 153 02682	AN7591
7304	4822 130 11578	STP16NE06
7307	4822 130 60373	BC856B
7308	5322 130 60159	BC847B
7309	4822 130 11336	STP16NE06FP
7310	4822 130 60373	BC856B
7313	4822 130 60373	BC857B
7325	5322 130 60159	BC847B
7326	4822 130 60373	BC856B
7328	4822 130 42804	BC817-25
7329	4822 130 42804	BC817-25
7505	5322 130 60159	BC847B
7506	9322 150 74668	TDA7468D
7700	4822 209 31378	NJM4556AM

Note : Only the parts mentioned in this list are normal service spare parts.

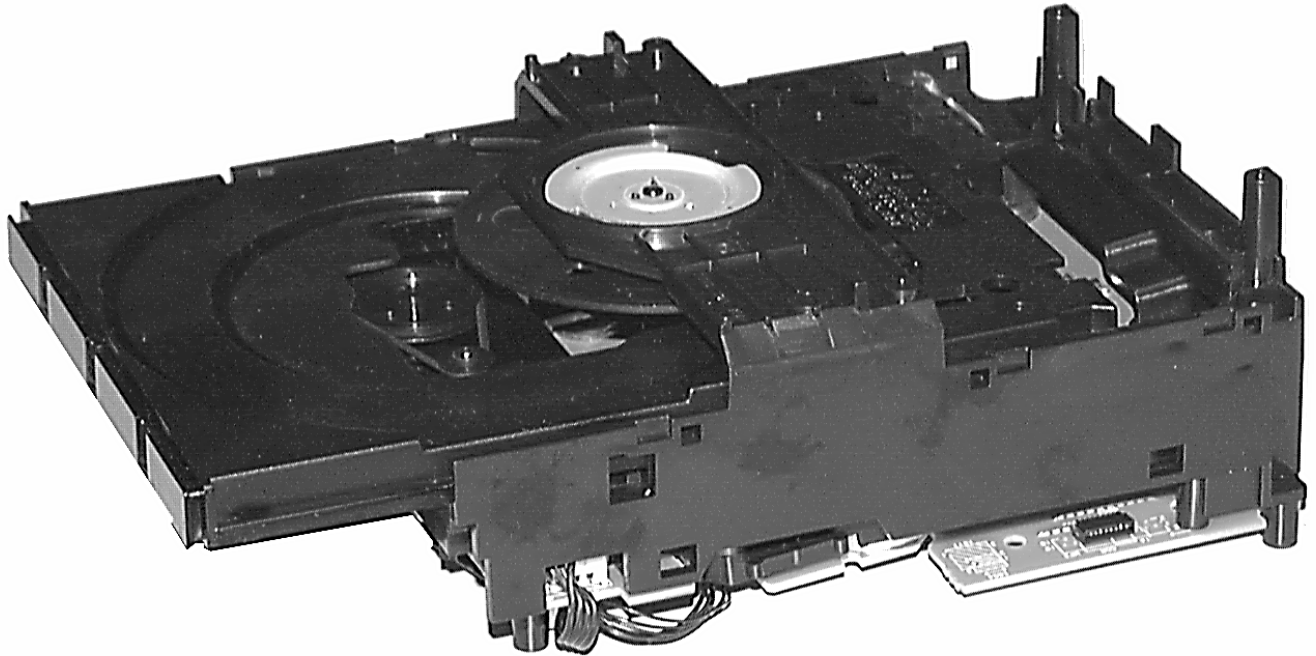

Universal Loader

(Single Disc Tray Loader)

Layout stage .5

TABLE OF CONTENTS

Pin description.....	10-2
Blockdiagram	10-3
Component Layout Main Board	10-4
Circuit Diagram	10-5
Exploded View	10-6
Partslist	10-7



Laser Power Control & HF Amplifier (ADALAS) TZA1024/TZA1025

<i>Pin</i>	<i>Name</i>	<i>Direction</i>	<i>Description</i>
1	LD	HF-preamp → CD-drive	current output to laser diode
2	VCCL	+5V	laser supply voltage
3	CFIL	→ HF-preamp	external filter capacitor
4	MON	CD-drive → HF-preamp	laser monitor diode input
5	DIN	CD-drive → HF-preamp	central diode input
6	GND	GND	ground
7	PWRON	CD10 → HF-preamp	power-on select input
8	CMFB	VrefCD10 (+3,3V / 2)	common mode feedback voltage input
9	RFFB	→ HF-preamp	external RF feedback resistor
10	RFEQO	HF-preamp →	RF amplifier output
11	CDRW	CD10 → HF-preamp	gain select input for CDDA/CDRW
12	EQSEL	CD10 → HF-preamp	equalizer/speed select input
13	VCC2	+3,3V	supply voltage
14	RGADJ	GND	external laser supply gain adjust resistor

SIGNAL PROCESSOR (CD10) SAA7325

<i>Pin</i>	<i>Name</i>	<i>Direction</i>	<i>Description</i>
1	HFREF	→ CD10	comparator common mode input
2	HFIN	→ CD10	comparator signal input
3	ISLICE	CD10 →	current feedback from data slicer
4	VSSA1	GND	analog ground 1
5	VDDA1	+3,3V	analog supply voltage 1
6	IREF	CD10 →	reference current output pin
7	VRIN	CD10 →	reference voltage for servo ADC's
8	D1	CD-drive → CD10	unipolar current input (central diode signal input)
9	D2	CD-drive → CD10	unipolar current input (central diode signal input)
10	D3	CD-drive → CD10	unipolar current input (central diode signal input)
11	D4	CD-drive → CD10	unipolar current input (central diode signal input)
12	R1	CD-drive → CD10	unipolar current input (satellite diode signal input)
13	R2	CD-drive → CD10	unipolar current input (satellite diode signal input)
14	VSSA2	GND	analog ground 2
15	CROUT	CD10 → X-TAL	crystal/resonator output
16	CRIN	X-TAL → CD10	crystal/resonator input
17	VDDA2	+3,3V	analog supply voltage 2
18	LN	CD10 →	DAC left channel differential output - negative
19	LP	CD10 →	DAC left channel differential output - positive
20	VNEG	GND	DAC negative reference input
21	VPOS	+3,3V	DAC positive reference input
22	RN	CD10 →	DAC right channel differential output - negative
23	RP	CD10 →	DAC right channel differential output - positive
24	SELPLL	CD10 →	selects whether internal clock multiplier PLL is used
25	TEST1	GND	test control input 1; this pin should be tied low
26	CL16	CD10 → NPC	16.9344 MHz system clock output
27	DATA	CD10 → NPC	serial data output (3-state)
28	WCLK	CD10 → NPC	word clock output (3-state)
29	SCLK	CD10 → NPC	serial bit clock output (3-state)
30	EF	CD10 → NPC	C2 error flag output (3-state)
31	TEST2	GND	test control input 2; this pin should be tied low
32	KILL	CD10 → Mute control	kill output (programmable; open-drain)
33	VSSD1	GND	digital ground 2
34	V2/V3	CD10 → NPC	versatile I/O: input versatile pin 2 or output versatile pin 3 (open-drain)
35	WCLI	NPC → CD10	word clock input (for data loopback to DAC)
36	SDI	NPC → CD10	serial data input (for data loopback to DAC)
37	SCLI	NPC → CD10	serial bit clock input (for data loopback to DAC)
38	RESETn	μP → CD10	power-on reset input (active low)
39	SDA	μP ↔ CD10	microcontroller interface data I/O line (open-drain output)
40	SCL	μP → CD10	microcontroller interface clock line input
41	RAB	μP → CD10	microcontroller interface R/W and load control line input (4-wire bus mode)
42	SILD	μP → CD10	microcontroller interface R/W and load control line input (4-wire bus mode)
43	STATUS	CD10 →	servo interrupt request line/decoder status register output (open-drain)
44	TEST3	GND	test control input 3; this pin should be tied low
45	RCK	→ CD10	subcode clock input
46	SUB	CD10 →	P-to-W subcode bits output (3-state)
47	SFSY	CD10 → μP	subcode frame sync output (3-state)
48	SBSY	CD10 → NPC	subcode block sync output (3-state)
49	CL11/4	CD10 →	11.2896 MHz or 4.2336 MHz (for microcontroller) clock output
50	VSSD2	GND	digital ground 3
51	DOBM	CD10 →	bi-phase mark output (externally buffered; 3-state)
52	VDDD1P	+3,3V	digital supply voltage 2 for periphery
53	CFLG	CD10 →	correction flag output (open-drain)
54	RA	CD10 → servo driver	radial actuator output
55	FO	CD10 → servo driver	focus actuator output
56	SL	CD10 → servo driver	slide control output
57	VDDD2C	+3,3V	digital supply voltage 3 for core
58	VSSD3	GND	digital ground 4
59	MOTO1	CD10 → servo driver	motor output 1; versatile (3-state)
60	MOTO2	CD10 →	motor output 2; versatile (3-state)
61	V4	CD10 → HF-preamp	versatile output pin 4
62	V5	CD10 → HF-preamp	versatile output pin 5
63	V1	innerswitch → CD10	versatile input pin 1
64	LDON	CD10 → HF-preamp	laser drive on output (open-drain)

BLOCK DIAGRAM Universal Loader Internet Audio Version

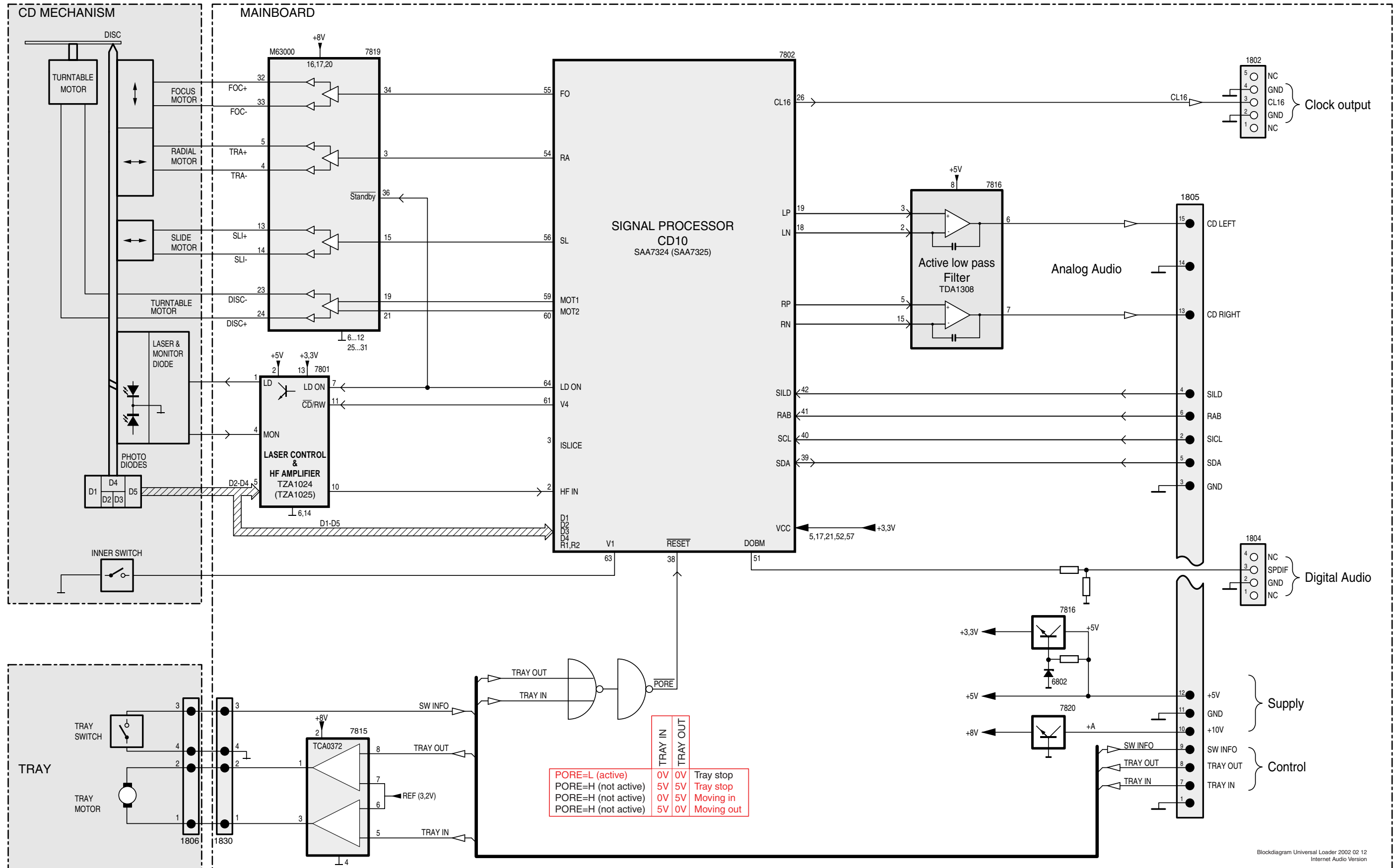

CD Board Copperside view (Universal Loader)

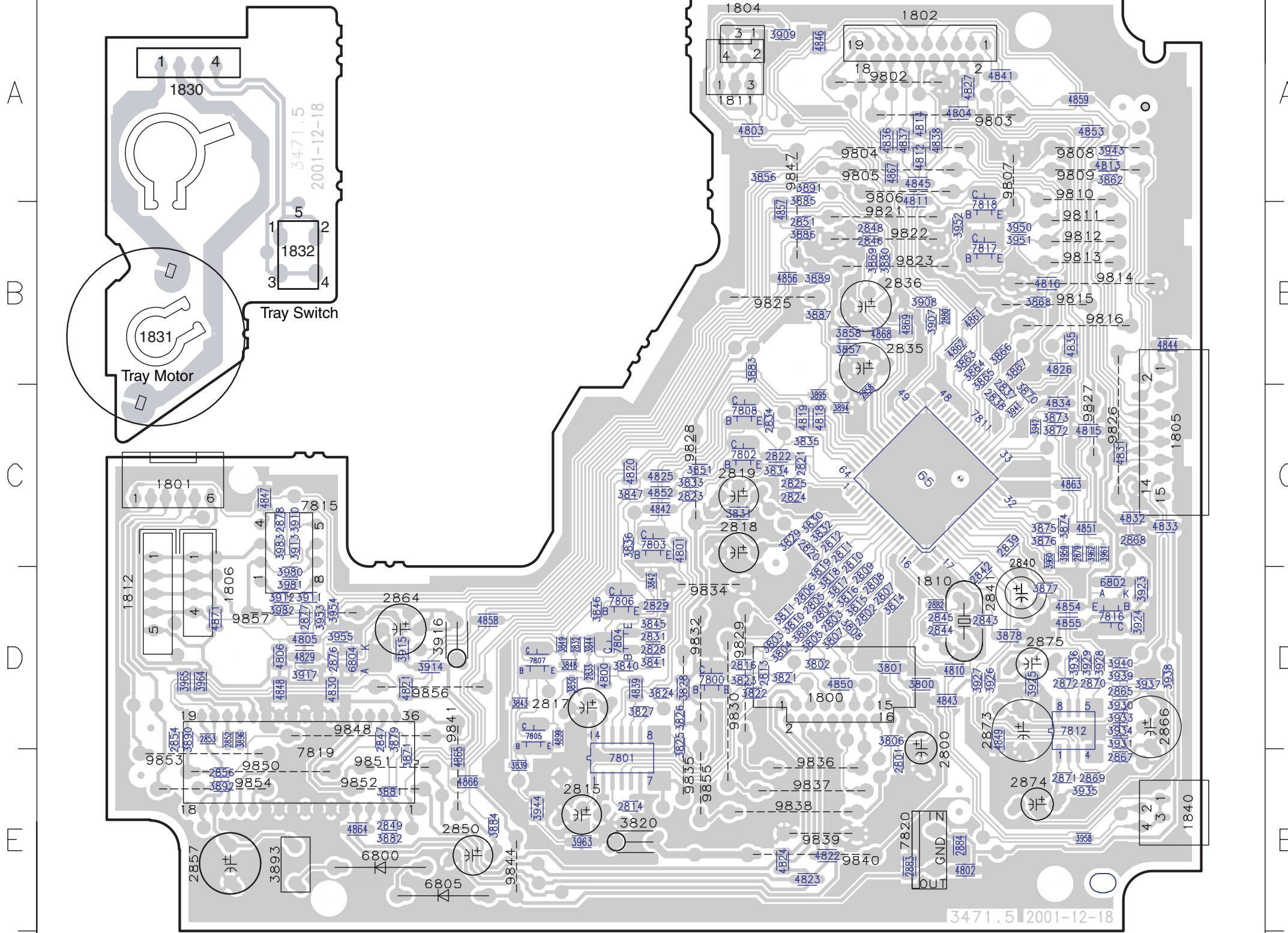

This assembly drawing shows a summary of all possible versions. For components used in a specific version see schematic diagram respectively partslist.

Mapping SMD parts

2801 E5	3835 C4	3961 C6
2802 D5	3836 C3	3962 C6
2803 D4	3839 E3	3963 E3
2804 D4	3840 D3	3964 D1
2805 D4	3841 D3	3965 D1
2806 D4	3842 D3	3980 D2
2807 D5	3843 D3	3981 D2
2808 D5	3844 D3	3982 D1
2809 D5	3845 D3	3983 C1
2810 C5	3846 D3	4800 D3
2811 C5	3847 C3	4801 C4
2812 C4	3848 D3	4802 E5
2813 D4	3849 D3	4803 A4
2814 E3	3850 D3	4804 A5
2816 D4	3851 C4	4805 D2
2820 C4	3856 A4	4806 D1
2821 C4	3857 B5	4810 D5
2822 C4	3858 B5	4811 A5
2823 C4	3862 A6	4812 A5
2824 C4	3863 B5	4813 A6
2825 C4	3864 B5	4814 A5
2828 D3	3865 B5	4815 C6
2829 D4	3866 B5	4816 B6
2831 D3	3867 B5	4818 C4
2832 D3	3868 B6	4819 C4
2833 D3	3869 B5	4820 C3
2834 C4	3870 C6	4821 D2
2837 C5	3871 E2	4822 E4
2838 C5	3872 C6	4823 E4
2839 C5	3873 C6	4824 E4
2842 D5	3874 C6	4825 C4
2843 D5	3875 C6	4826 B6
2844 D5	3876 C6	4827 A5
2845 D5	3877 D6	4829 D2
2846 B5	3878 D5	4830 D2
2847 D2	3879 D2	4831 C6
2848 B5	3880 B5	4832 C6
2849 E2	3881 E2	4833 C6
2851 B4	3882 E2	4834 C6
2852 D1	3883 B4	4835 B6
2853 D1	3884 E3	4836 A5
2854 D1	3885 A4	4837 A5
2856 E1	3886 B4	4838 A5
2858 C5	3887 B4	4839 D3
2865 D6	3889 B4	4841 A5
2867 E6	3890 D1	4842 C4
2868 C6	3891 A4	4843 D5
2869 E6	3892 E1	4844 B6
2870 D6	3894 C5	4845 A5
2871 E6	3895 C4	4846 A4
2872 D6	3896 D1	4847 C1
2876 D2	3907 B5	4848 D1
2877 D2	3908 B5	4849 D5
2878 C1	3909 A4	4850 D5
2879 C6	3910 C2	4851 C6
2880 B5	3911 D2	4852 C4
2882 D5	3912 D1	4853 A6
2883 E5	3913 C2	4854 D6
2884 E5	3914 D2	4855 D6
3800 D5	3915 D2	4856 B4
3801 D5	3917 D2	4857 B4
3802 D4	3923 D6	4858 D3
3803 D4	3924 D6	4859 A6
3804 D4	3925 D6	4861 B5
3805 D4	3926 D5	4862 B5
3806 D5	3927 D5	4863 C6
3807 D4	3928 D6	4864 E2
3808 D5	3929 D6	4865 E2
3809 D4	3930 D6	4866 E2
3810 D4	3931 D6	4867 A5
3811 D4	3933 D6	4868 B5
3814 D5	3934 D6	4869 B5
3815 D5	3935 E6	4871 D1
3816 D5	3936 D6	4899 D3
3817 D5	3937 D6	6802 D6
3818 D4	3938 D6	6804 D2
3819 D4	3939 D6	7800 D4
3821 D4	3940 D6	7801 E3
3822 D4	3941 C5	7802 C4
3823 D4	3942 C6	7803 C3
3824 D4	3943 A6	7804 D3
3825 D4	3944 E3	7805 D3
3826 D4	3950 B5	7806 D3
3827 D3	3951 B5	7807 D3
3828 D4	3952 B5	7808 C4
3829 C4	3953 D2	7811 C5
3830 C4	3954 D2	7812 D6
3831 C4	3955 D2	7816 D6
3832 C4	3958 E6	7817 B5
3833 C4	3959 C6	7818 B5
3834 C4	3960 C6	

HMC parts

1800 D4
1801 C1
1802 A5
1804 A4
1805 C6
1806 D1
1810 D5
1811 A4
1812 D1
1830 A1
1831 B1
1832 B1
1840 E6
2800 D5
2815 E3
2817 D3
2818 C4
2819 C4
2835 B5
2836 B5
2840 D6
2841 D5
2850 E3
2857 E1
2864 D2
2866 D6
2873 D5
2874 E6
2875 D6
3893 E2
3916 D2
6800 E2
6805 E2
7815 C1
7819 E2
7820 E5
9802 A5
9803 A5
9804 A5
9805 A5
9806 A5
9807 A6
9808 A6
9809 A6
9810 A6
9811 B6
9812 B6
9813 B6
9814 B6
9815 B6
9816 B6
9821 B5
9822 B5
9823 B5
9825 B4
9826 C6
9827 C6
9828 C4
9829 D4
9830 D4
9831 D4
9832 D4
9833 D4
9834 D4
9835 D4
9836 E4
9837 E4
9838 E4
9839 E4
9840 E4
9841 E2
9842 E3
9843 E3
9844 E3
9848 D2
9849 E1
9850 E1
9851 E2
9852 E2
9853 D1
9854 E1
9855 E4
9856 D2
9857 D2

1800	D1	1810	B10	2802	A5	2808	A5	2814	E4	2820	D10	2835	F12	2842	B11	2848	G5	2854	I5	2866	A12	2872	B14	2878	J13	3801	C1	3807	A4	3815	A5	3821	E2	3827	D6	3835	E10	3864	D14	3871	H5	3881	G5	3887	I5	3895	I5	3912	H13	3925	A12	3931	A12	3938	A15	3955	I15	3983	J13	7812A	A13	7818	I10
1801	G1	1830	H13	2803	B5	2809	B5	2815	E4	2821	E9	2836	G13	2843	B10	2849	G4	2856	J5	2867	A12	2873	A12	2879	B15	3802	C3	3808	B4	3816	B5	3822	E2	3828	E7	3836	G10	3865	D14	3873	B14	3882	G5	3889	I5	3896	I4	3913	J13	3926	A12	3933	A13	3939	B14	3959	B14	6802	G15	7812B	B13	7819	F3
1802	B15	1831	H13	2804	B5	2810	B5	2816	E3	2823	E9	2837	E14	2844	B10	2850	I4	2857	H4	2868	I15	2874	A14	2880	F14	3803	C3	3809	B4	3817	B5	3823	E3	3829	D9	3837	G12	3866	D14	3877	E11	3883	F10	3890	I5	3897	F13	3914	I14	3927	A13	3934	A14	3942	B14	6804	J15	7815-A	I13	7820	H15		
1804	F15	1832	H13	2805	B5	2811	B5	2817	E6	2824	F10	2839	D14	2845	B10	2851	J4	2858	F12	2869	A13	2875	H14	3804	C3	3810	B4	3818	B5	3824	F3	3831	E9	3837	E9	3845	E9	3853	D14	3878	B10	3884	H4	3891	J5	3908	F14	3915	I14	3928	G15	3929	B12	3936	B14	3951	J11	3981	J14	7801	E5	7816	G15
1805	H15	2800	C1	2806	C5	2812	C5	2818	E7	2825	F10	2839	B11	2846	H5	2852	I4	2864	I13	2870	B13	2876	J15	2884	H15	3805	C4	3811	C4	3819	C5	3825	E7	3832	E10	3840	C15	3868	C14	3879	G5	3885	J4	3892	J5	3910	J14	3923	G15	3929	B12	3936	B14	3951	J11	3981	J14	7801	E5	7816	G15		
1806	H13	2801	A5	2807	A5	2813	A5	2819	E10	2828	H7	2841	B11	2847	G4	2853	I4	2865	B12	2871	A14	2877	I13	3800	C1	3806	A4	3814	A5	3820	E4	3826	E7	3834	E9	3842	D14	3869	H5	3880	G5	3886	J4	3894	I5	3911	I14	3924	G15	3930	A12	3937	A14	3952	I13	7811	D12	7817	J11				

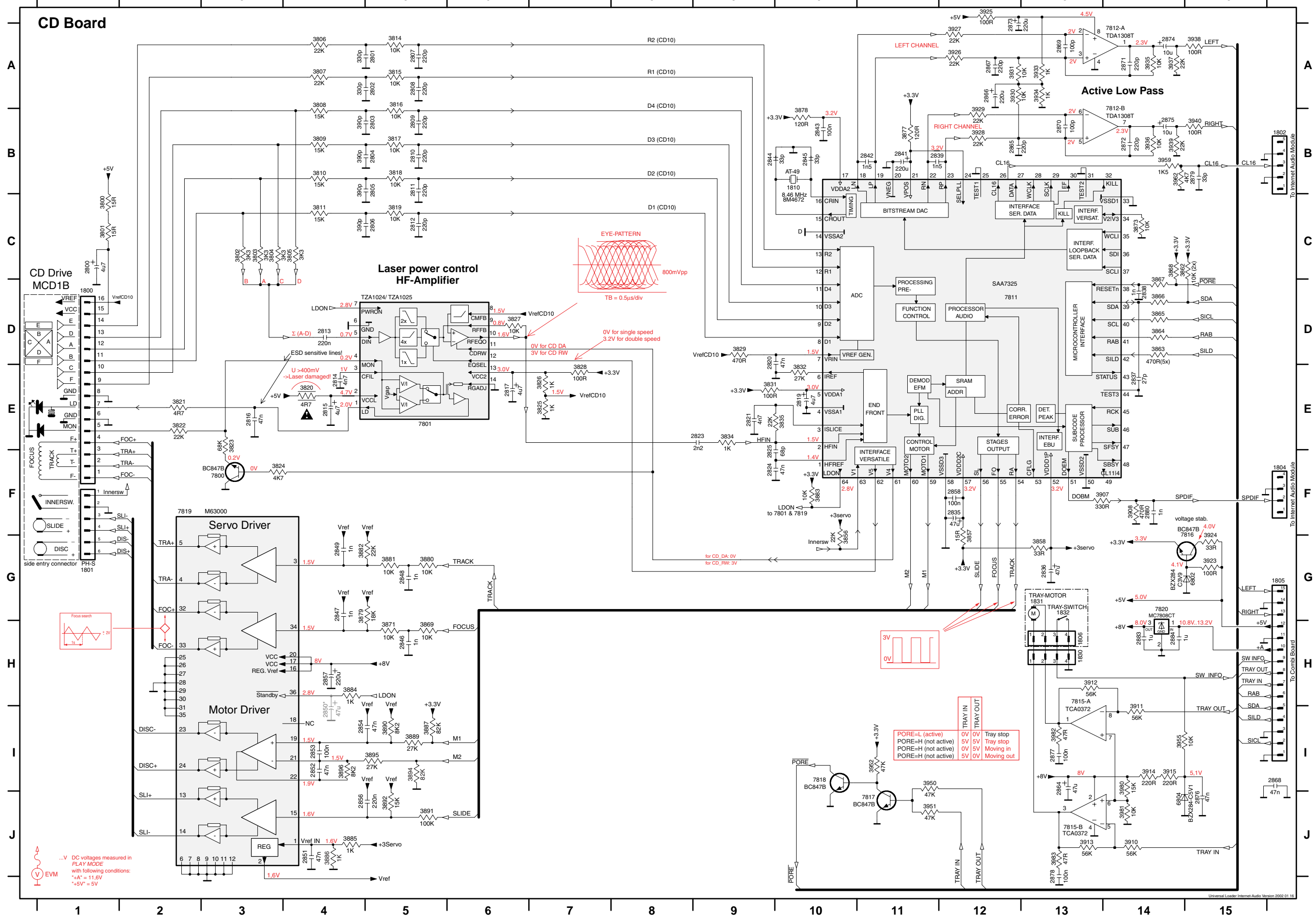

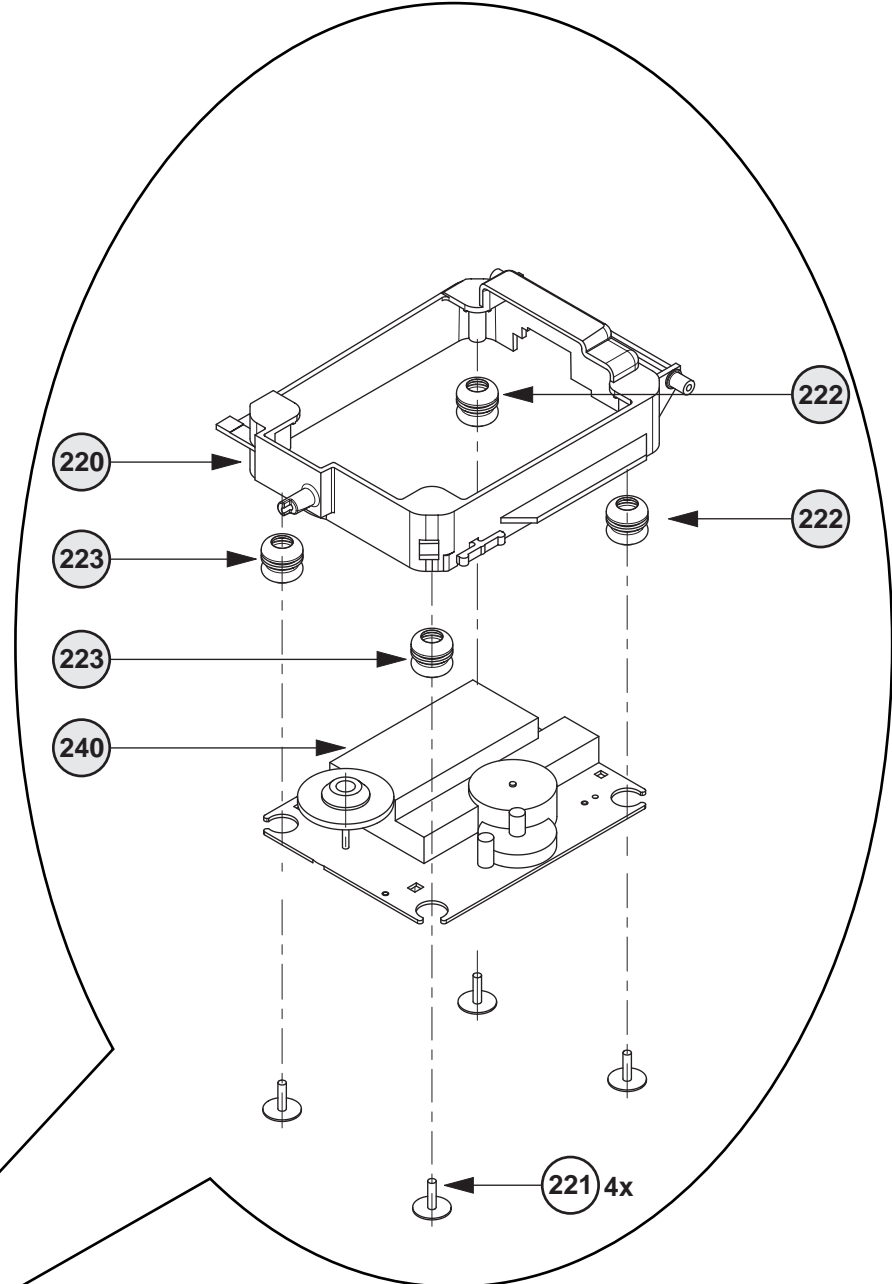
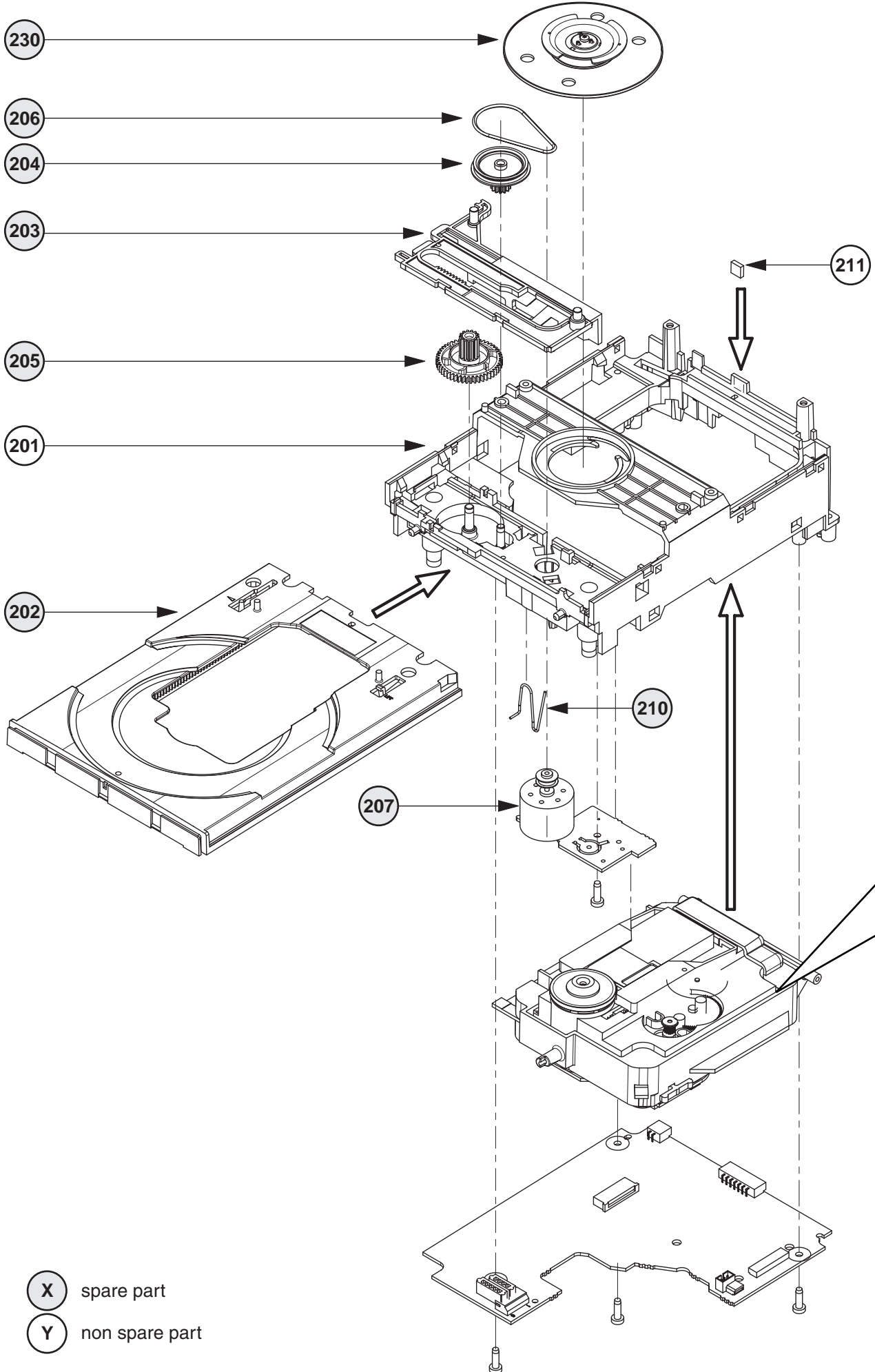

(X) spare part
 (Y) non spare part

MECHANICAL PARTS

202	3103 304 71780	DRAWER
203	3103 304 71800	SLIDER
204	3103 304 71820	PULLEY GEARWHEEL
205	3103 304 71830	GEARWHEEL
206	3103 304 71910	DRIVING BELT
207	3103 308 54160	MOTOR ASSY
210	3103 301 06660	SPRING SUPPORT
220	3103 304 71790	SUPPORT CD
222	4822 529 10387	RUBBER DAMPER CD DRIVE, FRONT
223	4822 529 10387	RUBBER DAMPER CD DRIVE, FRONT
230	3103 308 11940	CLAMPER ASSY DA11
240	3103 309 05350	CD DRIVE MCD1B

ELECTRICAL PARTSLIST Universal Loader Internet Audio Version**MISCELLANEOUS**

1800	2422 025 12133	FFC CONNECTOR 16P
1802	2422 025 16925	FFC-CONNECTOR 5P, SIDE ENTRY
1804	2422 025 16979	FFC-CONNECTOR 4P, SIDE ENTRY
1805	4822 265 10979	FFC-CONNECTOR 15P, SIDE ENTRY
1832	2422 129 16655	LEAF SWITCH 1P

8000	3103 308 92850	FLEX FOIL CABLE 16Pin/100mm BD
------	----------------	--------------------------------

CAPACITORS

2800	4822 124 22726	4,7μF	20%	35V
2801©	4822 126 14241	330pF		50V
2802©	4822 126 14241	330pF		50V
2803©	4822 126 14315	390pF	5%	50V
2804©	4822 126 14315	390pF	5%	50V

2805©	4822 126 14315	390pF	5%	50V
2806©	4822 126 14315	390pF	5%	50V
2807©	4822 126 13883	220pF	5%	50V
2808©	4822 126 13883	220pF	5%	50V
2809©	4822 126 13883	220pF	5%	50V

2810©	4822 126 13883	220pF	5%	50V
2811©	4822 126 13883	220pF	5%	50V
2812©	4822 126 13883	220pF	5%	50V
2813©	4822 126 13879	220nF	20%	16V
2814©	4822 126 13193	4,7nF	10%	63V

2815	4822 124 22726	4,7μF	20%	35V
2816©	3198 024 44730	47nF	5%	50V
2817	4822 124 22726	4,7μF	20%	35V
2819	4822 124 22726	4,7μF	20%	35V
2820©	3198 024 44730	47nF	5%	50V

2821©	4822 126 13193	4,7nF	10%	63V
2823©	4822 126 14238	2,2nF	10%	50V
2824©	3198 024 44730	47nF	5%	50V
2825©	4822 126 13956	68pF	5%	63V
2835	4822 124 12362	47μF	20%	4V

2836	4822 124 12362	47μF	20%	4V
2837©	4822 126 11669	27pF	10%	50V
2838©	5322 126 11578	1nF	10%	63V
2839©	2238 916 11552	1,5nF	5%	25V
2841	4822 124 42383	220μF	20%	4V

2842©	2238 916 11552	1,5nF	5%	25V
2843©	4822 126 14305	100nF	10%	16V
2844©	2222 867 15339	33pF	5%	50V
2845©	2222 867 15339	33pF	5%	50V
2846©	3198 016 31020	1nF	5%	25V

2847©	3198 016 31020	1nF	5%	25V
2848©	3198 016 31020	1nF	5%	25V
2849©	3198 016 31020	1nF	5%	25V
2851©	3198 024 44730	47nF	5%	50V
2852©	3198 024 44730	47nF	5%	50V

2853©	4822 126 14305	100nF	10%	16V
2854©	3198 024 44730	47nF	5%	50V
2856©	4822 126 13879	220nF	20%	16V
2857	4822 124 80144	220μF	20%	25V
2858©	4822 126 14305	100nF	10%	16V

2864	4822 124 81286	47μF	20%	16V
2865©	4822 126 13883	220pF	5%	50V
2866	3198 029 12210	220μF	20%	10V
2867©	4822 126 13883	220pF	5%	50V
2868©	3198 024 44730	47nF	5%	50V

2869©	4822 122 31765	100pF	5%	50V
2870©	4822 122 31765	100pF	5%	50V
2871©	4822 126 13883	220pF	5%	50V
2872©	4822 126 13883	220pF	5%	50V
2873	3198 029 12210	220μF	20%	10V

CAPACITORS

2874	4822 124 21732	10μF	20%	25V
2875	4822 124 21732	10μF	20%	25V
2876©	3198 024 44730	47nF	5%	50V
2877©	4822 126 14305	100nF	10%	16V
2878©	4822 126 14305	100nF	10%	16V

2879©	4822 122 31765	100pF	5%	50V
2880©	3198 016 31020	1nF	5%	25V
2883©	4822 126 14043	1μF	20%	16V
2884©	4822 126 14043	1μF	20%	16V

RESISTORS

3800©	4822 051 20159	15Ω	5%	0,1W
3801©	4822 051 20159	15Ω	5%	0,1W
3802©	4822 051 30332	3,3kΩ	5%	0,06W
3803©	4822 051 30332	3,3kΩ	5%	0,06W
3804©	4822 051 30332	3,3kΩ	5%	0,06W

3805©	4822 051 30332	3,3kΩ	5%	0,06W
3806©	4822 051 30223	22kΩ	5%	0,06W
3807©	4822 051 30223	22kΩ	5%	0,06W
3808©	4822 051 30153	15kΩ	5%	0,06W
3809©	4822 051 30153	15kΩ	5%	0,06W

3810©	4822 051 30153	15kΩ	5%	0,06W
3811©	4822 051 30153	15kΩ	5%	0,06W
3814©	4822 051 30103	10kΩ	5%	0,06W
3815©	4822 051 30103	10kΩ	5%	0,06W
3816©	4822 051 30103	10kΩ	5%	0,06W

3817©	4822 051 30103	10kΩ	5%	0,06W
3818©	4822 051 30103	10kΩ	5%	0,06W
3819©	4822 051 30103	10kΩ	5%	0,06W
3820▲	4822 052 10478	4,7Ω	5%	NFR25
3821©	4822 117 13608	4,7Ω	5%	0,06W

3822©	4822 051 30223	22kΩ	5%	0,06W
3823©	4822 051 30683	68kΩ	5%	0,06W
3824©	4822 051 30472	4,7kΩ	5%	0,06W
3825©	4822 051 30102	1kΩ	5%	0,06W
3826©	4822 051 10102	1kΩ	2%	0,25W

3827©	4822 051 30103	10kΩ	5%	0,06W
3828©	4822 117 11373	100Ω	1%	0,1W
3829©	4822 051 30471	470Ω	5%	0,06W
3831©	4822 051 30101	100Ω	5%	0,06W
3832©	4822 051 30273	27kΩ	5%	0,06W

3834©	4822 051 30102	1kΩ	5%	0,06W
3835©	4822 051 30223	22kΩ	5%	0,06W
3856©	4822 051 30223	22kΩ	5%	0,06W
3857©	4822 051 20159	15Ω	5%	0,1W
3858©	4822 051 20339	33Ω	5%	0,1W

3863©	4822 051 30471	470Ω	5%	0,06W
3864©	4822 051 30471	470Ω	5%	0,06W
3865©	4822 051 30471	470Ω	5%	0,06W
3866©	4822 051 30471	470Ω	5%	0,06W
3867©	4822 051 30471	470Ω	5%	0,06W

3868©	4822 051 30103	10kΩ	5%	0,06W
3869©	4822 051 30103	10kΩ	5%	0,06W
3871©	4822 051 30103	10kΩ	5%	0,06W
3873©	4822 051 30103	10kΩ	5%	0,06W
3877©	4822 051 30121	120Ω	5%	0,06W

3878©	4822 051 20121	120Ω	5%	0,1W
3879©	4822 051 30183	18kΩ	5%	0,06W
3880©	4822 051 30103	10kΩ	5%	0,06W
3881©	4822 051 30103	10kΩ	5%	0,06W
3882©	4822 051 30223	22kΩ	5%	0,06W

3883©	4822 051 30103	10kΩ	5%	0,06W
3884©	4822 051 30102	1kΩ	5%	0,06W
3885©	4822 051 30102	1kΩ	5%	0,06W

ELECTRICAL PARTSLIST Universal Loader Internet Audio Version**RESISTORS**

3886	4822 051 30102	1kΩ	5%	0,06W
3887	4822 117 12864	82kΩ	5%	0,06W
3889	4822 051 30273	27kΩ	5%	0,06W
3890	4822 117 12902	8,2kΩ	1%	0,06W
3891	4822 117 13632	100kΩ	1%	0,06W

3892	4822 051 30153	15kΩ	5%	0,06W
3894	4822 117 12864	82kΩ	5%	0,06W
3895	4822 051 30273	27kΩ	5%	0,06W
3896	4822 117 12902	8,2kΩ	1%	0,06W
3907	4822 051 30331	330Ω	5%	0,06W

3908	4822 051 30471	470Ω	5%	0,06W
3910	2322 704 65603	56kΩ	1%	0,06W
3911	2322 704 65603	56kΩ	1%	0,06W
3912	2322 704 65603	56kΩ	1%	0,06W
3913	2322 704 65603	56kΩ	1%	0,06W

3914	4822 117 11503	220Ω	5%	0,1W
3915	4822 117 11503	220Ω	5%	0,1W
3923	4822 117 11373	100Ω	1%	0,1W
3924	4822 051 20339	33Ω	5%	0,1W
3925	4822 117 11373	100Ω	1%	0,1W

3926	4822 051 30223	22kΩ	5%	0,06W
3927	4822 051 30223	22kΩ	5%	0,06W
3928	4822 051 30223	22kΩ	5%	0,06W
3929	4822 051 30223	22kΩ	5%	0,06W
3930	4822 051 30103	10kΩ	5%	0,06W

3931	4822 051 30103	10kΩ	5%	0,06W
3933	4822 051 30102	1kΩ	5%	0,06W
3934	4822 051 30102	1kΩ	5%	0,06W
3935	4822 051 30103	10kΩ	5%	0,06W
3936	4822 051 30103	10kΩ	5%	0,06W

3937	4822 051 30223	22kΩ	5%	0,06W
3938	4822 051 30101	100Ω	5%	0,06W
3939	4822 051 30223	22kΩ	5%	0,06W
3940	4822 051 30101	100Ω	5%	0,06W
3943	4822 051 30103	10kΩ	5%	0,06W

3950	4822 117 12925	47kΩ	1%	0,06W
3951	4822 117 12925	47kΩ	1%	0,06W
3952	4822 117 12925	47kΩ	1%	0,06W
3955	4822 051 30103	10kΩ	5%	0,06W
3959	4822 051 30331	330Ω	5%	0,06W

3962	4822 051 30102	1kΩ	5%	0,06W
3964	4822 051 20008	CHIP JUMPER 0805		
3965	4822 051 20008	CHIP JUMPER 0805		
3980	4822 051 30153	15kΩ	5%	0,06W
3981	4822 051 30103	10kΩ	5%	0,06W

3982	4822 051 30479	47Ω	5%	0,06W
3983	4822 051 30479	47Ω	5%	0,06W
4800	4822 051 20008	CHIP JUMPER 0805		
4801	4822 051 20008	CHIP JUMPER 0805		
4804	4822 051 20008	CHIP JUMPER 0805		

4806	4822 051 20008	CHIP JUMPER 0805		
4811	4822 051 20008	CHIP JUMPER 0805		
4812	4822 051 20008	CHIP JUMPER 0805		
4813	4822 051 20008	CHIP JUMPER 0805		
4814	4822 051 20008	CHIP JUMPER 0805		

4815	4822 051 20008	CHIP JUMPER 0805		
4816	4822 051 20008	CHIP JUMPER 0805		
4818	4822 051 20008	CHIP JUMPER 0805		
4819	4822 051 20008	CHIP JUMPER 0805		
4820	4822 051 20008	CHIP JUMPER 0805		

4821	4822 051 20008	CHIP JUMPER 0805		
4822	4822 051 20008	CHIP JUMPER 0805		
4823	4822 051 20008	CHIP JUMPER 0805		
4824	4822 051 20008	CHIP JUMPER 0805		

RESISTORS

4825	4822 051 20008	CHIP JUMPER 0805		
4826	4822 051 20008	CHIP JUMPER 0805		
4827	4822 051 20008	CHIP JUMPER 0805		
4829	4822 051 20008	CHIP JUMPER 0805		
4830	4822 051 20008	CHIP JUMPER 0805		

4831	4822 051 20008	CHIP JUMPER 0805		
4832	4822 051 20008	CHIP JUMPER 0805		
4833	4822 051 20008	CHIP JUMPER 0805		
4834	4822 051 20008	CHIP JUMPER 0805		
4836	4822 051 20008	CHIP JUMPER 0805		

4837	4822 051 20008	CHIP JUMPER 0805		
4838	4822 051 20008	CHIP JUMPER 0805		
4839	4822 051 20008	CHIP JUMPER 0805		
4842	4822 051 20008	CHIP JUMPER 0805		
4843	4822 051 20008	CHIP JUMPER 0805		

4844	4822 051 20008	CHIP JUMPER 0805		
4845	4822 051 20008	CHIP JUMPER 0805		
4846	4822 051 20008	CHIP JUMPER 0805		
4847	4822 051 20008	CHIP JUMPER 0805		
4848	4822 051 20008	CHIP JUMPER 0805		

4849	4822 051 20008	CHIP JUMPER 0805		
4850	4822 051 20008	CHIP JUMPER 0805		
4851	4822 051 20008	CHIP JUMPER 0805		
4852	4822 051 20008	CHIP JUMPER 0805		
4854	4822 051 20008	CHIP JUMPER 0805		

4855	4822 051 20008	CHIP JUMPER 0805		
4856	4822 051 20008	CHIP JUMPER 0805		
4857	4822 051 20008	CHIP JUMPER 0805		
4858	4822 051 20008	CHIP JUMPER 0805		
4861	4822 051 20008	CHIP JUMPER 0805		

4862	4822 051 20008	CHIP JUMPER 0805		
4864	4822 051 20008	CHIP JUMPER 0805		
4865	4822 051 20008	CHIP JUMPER 0805		
4866	4822 051 20008	CHIP JUMPER 0805		
4867	4822 051 20008	CHIP JUMPER 0805		

4868	4822 051 20008	CHIP JUMPER 0805		
4869	4822 051 20008	CHIP JUMPER 0805		
4870	4822 051 20008	CHIP JUMPER 0805		
4871	4822 051 20008	CHIP JUMPER 0805		

COILS

1810	2422 543 01068	RESONATOR 8MHZ
------	----------------	----------------

DIODES

6802	9322 129 34685	BZX284-C3V9
6804	9340 548 52115	BZX284-C5V1

TRANSISTORS

7800	4822 130 60511	BC847B
7816	4822 130 60511	BC847B
7817	4822 130 60511	BC847B
7818	4822 130 60511	BC847B

INTEGRATED CIRCUITS

7801	4822 209 17286	TZA1024T/N1, HF-AMPLIFIER
7811	9352 641 80557	SAA7324H/M2B, "CD10" SIGN.PROC.
7812	4822 209 33165	TDA1308T/N1
7815	4822 209 62059	TCA0372DP1
7819	9322 158 56682	M63000SP, MOTOR DRIVER

7820	4822 209 72554	MC7808CT 8V Regulator
------	----------------	-----------------------

MECHANICAL & ACCESSORIES PARTS LIST - MAIN UNIT**SCREW LISTS - MAIN UNIT**

0101	3139 118 18360	Cabinet Front	/21M/22	0256	3139 114 76390	Panel Rear	/21M	225	M3 x 15
0101	3139 118 17920	Cabinet Front (V2)	/37	0256	3139 114 76020	Panel Rear	/22	226	M3 x 6
0102	3139 118 19491	Panel Front	/21M/37	0256	3139 114 75370	Panel Rear (V2)	/37	227	M3 x 6
0102	3139 257 51131	Panel Front	/22	0271	3139 114 71010	Stopper Heatsink		228	M3 x 6
0105	3139 257 51551	Cap Power Chrome		0348	3139 119 00851	L/R Loudspeaker Box	/21M	229	M3 x 6
0107	3139 114 75000	Button Power		0348	3139 119 01371	L/R Loudspeaker Box	/22	230	D3 x 10
0108	3139 118 17770	Button Set Sound Chrome		0348	3139 119 00801	L/R Loudspeaker Box	/37	231	M3 x 10
0110	3139 257 50161	Knob Volume	/21M/37	0351	4822 303 50063	FM Aerial	/21M/22	273	M3 x 6
0110	3139 118 17821	Knob Volume	/22	0351	4822 320 11094	FM Antenna	/37	274	M3 x 6
0111	3139 114 75330	Bracket Tilt Volume Rotary		0352	4822 303 50082	Antenna AM Loop		275	D3 x 35
0124	3139 118 19501	Window Display		0353	3139 238 04331	Remote Control		276	D3 x 12
0125	3139 113 27561	Frame Window Display	/21M/37	0356	2422 070 98151	△ Mains Cord	/21M/22	277	M3 x 10
0125	3139 114 75212	Frame Window Display	/22	0356	2422 070 98152	△ Mains Cord	/37	278	D3 x 10
0127	3139 118 17830	Ring Next/Prev Chrome		0358	3139 118 78840	Cable LAN RJ45		279	D3 x 16
0128	3139 118 17840	Ring Pause/Stop Chrome		0370	3139 115 22231	Instruction For Use	/21M	281	D3 x 10
0130	3139 114 75020	Button Set Display Left		0370	3139 115 22201	Instruction For Use	/22	282	D3 x 10
0131	3139 118 17780	Button Set Display Right Chrome		0370	3139 115 22071	Instruction For Use	/37	284	D3 x 10
0132	3139 114 75200	Lightbox		0371	3139 115 22211	Instruction For Use Book 2	/22	285	D3 x 10
0135	3139 118 17930	Cap Knob Shuttle		1105	3103 308 54761	Internet Audio Module G3.0-WL		286	D3 x 10
0136	3139 118 19511	Knob Shuttle		1106	3139 118 56981	PCBAS Antenna		287	M3 x 6
0137	3139 118 17790	Button Play Chrome		1110	2822 031 01494	Fan 12VDC 0,8W 3100RPM		288	M3 x 10
0138	3139 114 75340	Bracket Tilt Shuttle		1111	2822 031 01494	Fan 12VDC 0,8W 3100RPM		292	D3 x 10
0139	3139 118 19521	Cap Prev (Back)		1112	3139 118 79750	LCD (WD-G1306K-7BNN)		293	D3 x 10
0141	3139 114 75060	Button Set Prev/Pause		5001	3103 308 30790	△ Mains Transformer	/21M	294	D2 x 8
0142	3139 118 19541	Cap Next (Enter)		5001	3103 308 30770	△ Mains Transformer	/37	296	D3 x 10
0143	3139 118 19551	Cap Stop (Cancel)		8001	3139 110 36150	FFC Foil 15P/280/15P AD		297	D2 x 8
0144	3139 114 75070	Button Set Next/Stop		8002	3139 110 35400	FFC Foil 09P/340/09P AD		298	D3 x 10
0145	3139 118 19561	Cap Mode		8003	3139 110 35240	FFC Foil 08P/280/08P AD Fold		299	D2 x 8
0146	3139 114 75090	Button Set Mode/Option		8004	3139 110 34600	FFC Foil 07P/280/07P AD		300	D3 x 10
0158	3139 118 19581	Cover Tray	/21M/37	8005	3139 110 36140	FFC Foil 04P/180/04P AD		301	D3 x 10
0158	3139 118 17762	Cover Tray	/22	8006	3139 110 34970	FFC Foil 19P/180/19P AD		302	D3 x 10
0159	3139 114 78641	Ring Cover Tray		8007	3139 110 36020	FFC Foil 05P/340/05P AD 1mmP		303	D3 x 10
0160	3139 118 19591	Button Open/Close	/21M/37	8008	3139 110 36010	FFC Foil 04P/340/04P AD 1mmP		304	D3 x 10
0160	3139 118 17802	Button Open/Close	/22	8009	3139 110 34360	FFC Foil 06P/280/06P AD		305	D2 x 8
0161	3139 118 17850	Ring Open/Close Chrome		8010	4822 320 12654	FFC Foil 07P/220/07P AD			
0246	3139 113 27270	Foot Rubber 11x11x4mm		8013	3139 111 02611	Cable CRC 1P/280/1P CRC F-MF			
0250	3139 114 78651	Bracket Antenna		8014	3139 111 02611	Cable CRC 1P/280/1P CRC F-MF			
0252	3139 114 75290	Bracket Combi		8121	4822 320 12702	FFC Foil 06P/140/06P BD			
0253	3139 114 76040	Panel Left	/21M/22	8122	3139 110 36180	FFC Foil 09P/140/09P BD			
0253	3139 114 75880	Panel Left (V2)	/37	8123	3139 110 36220	FFC Foil 16P/180/16P AD			
0254	3139 114 76050	Panel Right	/21M/22						
0254	3139 114 75890	Panel Right (V2)	/37						
0255	3139 114 76030	Cover Top	/21M/22						
0255	3139 114 75380	Cover Top (V2)	/37						

Note : Only the parts mentioned in this list are normal service spare parts.