

11. Vue éclatée et liste des pièces

11-1 Compartiment congélateur

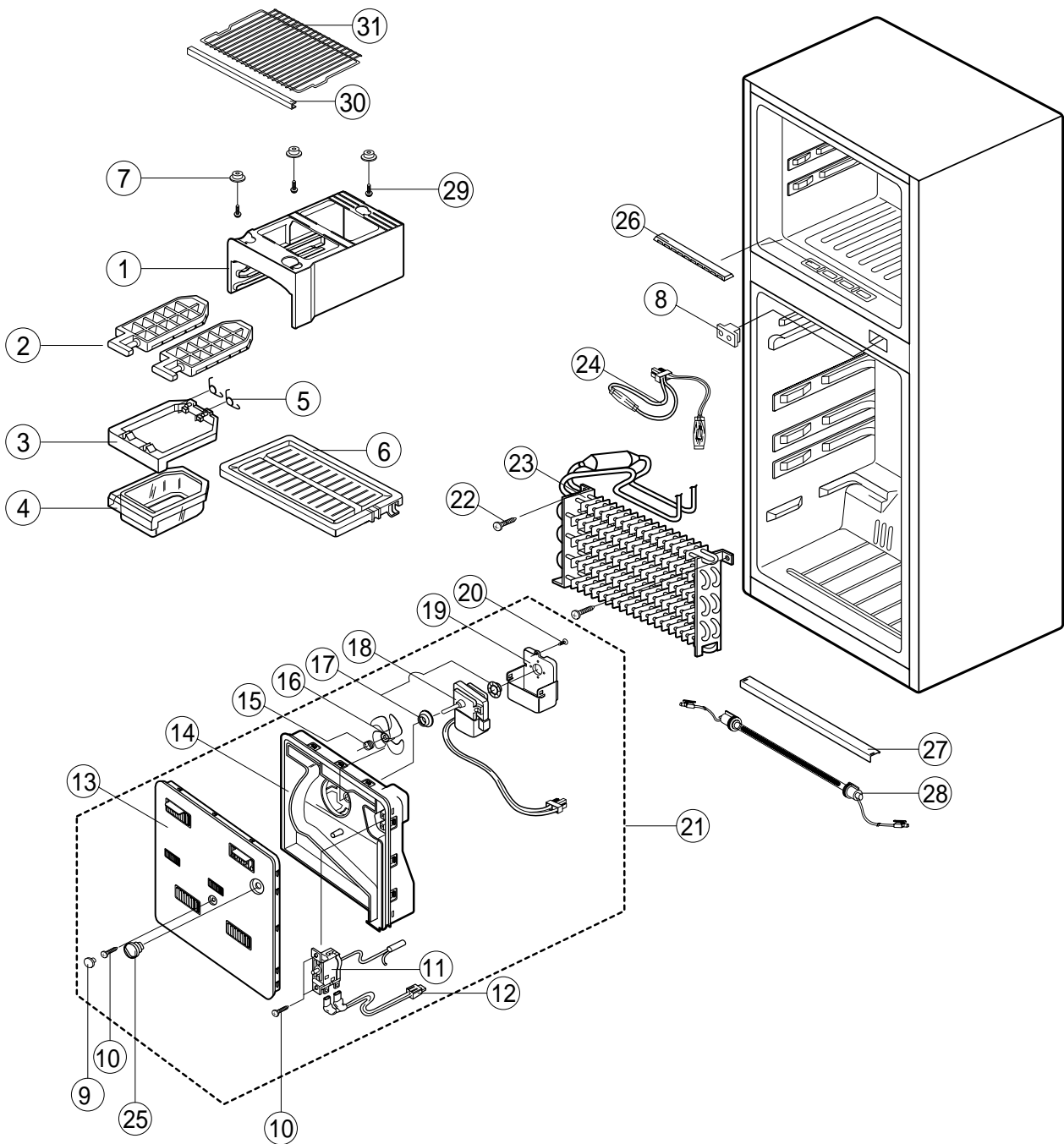

N°	Code	Désignation	Spécification	SR-32/33					SR-28/29					
				H	M	L	N	G	H	M	L	N	G	
1	DA61-70002A	BASE-TRAY, ICE	HIPS	1	1	1	1	1	1	1	1	1	1	1
2	DA67-40180A	TRAY-ICE(A)	P,P	2	2	2	2	2	2	2	2	2	2	2
3	DA67-10252B	CASE-TRAY, ICE	HIPS	1	1	1	1	1	1	1	1	1	1	1
4	DA67-10210C	TRAY-ICE, CUBE(A)	GPPS	1	1	1	1	1	1	1	1	1	1	1
5	DA61-20119A	SPRING-ICE	PI1.0 L162.6	2	2	2	2	2	2	2	2	2	2	2
6	DA67-20167A	SHELF-FRE	GPPS	1	1	1	0	0	1	1	0	0	0	0
7	DA71-20252A	FIXER-GROMMET D/FRE	ABS	3	3	3	3	3	3	3	3	3	3	3
8	3523-202-340	SWITCH-DOOR	NY 694 VO	1	1	1	1	1	1	1	1	1	1	1
9	DA67-30266D	CAP-SCREW	P,P	1	1	1	1	1	1	1	1	1	1	1
10	6002-000454	SCREW-TAP, TH	2-4 X 12 STS304	2	2	2	2	2	2	2	2	2	2	2
11	DA47-10107H	THERMOSTAT	PCC PFN174S	1	1	1	1	1	1	1	1	1	1	1
12	DA39-20124C	WIRE-LEAD, THERMO	-	1	1	1	1	1	1	1	1	1	1	1
13	DA63-10246S	COVER-EVAP, FR	P,P	1	1	1	1	1	1	1	1	1	1	1
14	DA63-10254A	COVER-EVAP, RE	ABS SCRAP	1	1	1	1	1	1	1	1	1	1	1
15	DA61-20128B	SPRING-FAN	STS 27	1	1	1	1	1	1	1	1	1	1	1
16	DA31-20002A	FAN	ABS	1	1	1	1	1	1	1	1	1	1	1
17	DA63-40119A	GROMMET-FAN, MOTOR	SILICON	2	2	2	2	2	2	2	2	2	2	2
18	DA31-10109S	MOTOR (220~240V)	IS3210-SNC7A	1	1	1	1	1	1	1	1	1	1	1
	DA31-10109V	" (110V~127V)	IS3210-SNP6A	1	1	1	1	1	1	1	1	1	1	1
19	DA63-10459A	COVER-FAN, MOTOR	P,P	1	1	1	1	1	1	1	1	1	1	1
20	6002-000454	SCREW-TAP, TH	1-4 X 12 FE, FZY	1	1	1	1	1	1	1	1	1	1	1
21	DA63-110001N	COVER-EVAP,ASSY(110V~127V)		1	1	1	1	1	1	1	1	1	1	1
	DA63-110001M	COVER-EVAP,ASSY(220V~240V)												
22	6002-000213	SCREW-TAP,TH	2-4 X 12 STS304	2	2	2	2	2	2	2	2	2	2	2
23	DA59-40129A	EVAPORATOR	-	1	1	1	1	1	1	1	1	1	1	1
24	DA47-10103J	BIMETAL-THERMO	125, 250/50, 60-5/12	1	1	1	1	1	1	1	1	1	1	1
25	DA64-40126C	KNOB-F, THERMO	ABS	1	1	1	1	1	1	1	1	1	1	1
26	DA63-10886A	COVER-AIR	P,P	1	1	1	1	1	1	1	1	1	1	1
27	DA63-10488B	COVER-HEATER	A1050	1	1	1	1	1	1	1	1	1	1	1
28	DA47-20150K	HEATER-DEFROST	220V/130W	1	1	1	1	1	1	1	1	1	1	1
	DA47-20150H	"	240V/130W	1	1	1	1	1	1	1	1	1	1	1
	DA47-20150L	"	110V/130W	1	1	1	1	1	1	1	1	1	1	1
	DA47-20150N	"	127V/130W	1	1	1	1	1	1	1	1	1	1	1
29	6002-000454	SCREW-TAP,TH	2-4 X 12 STS304	3	3	3	3	3	3	3	3	3	3	3
30	DA64-20150M	TRIM-SHELF	RD-PVC	0	0	0	1	1	0	0	1	1	1	1
31	DA67-20168B	SHELF-FRE(WIRE)	MSWR10	0	0	0	1	1	0	0	1	1	1	1

Les pièces en rapport avec la sécurité électrique apparaissent en gris.

11-2 Compartiment réfrigérateur

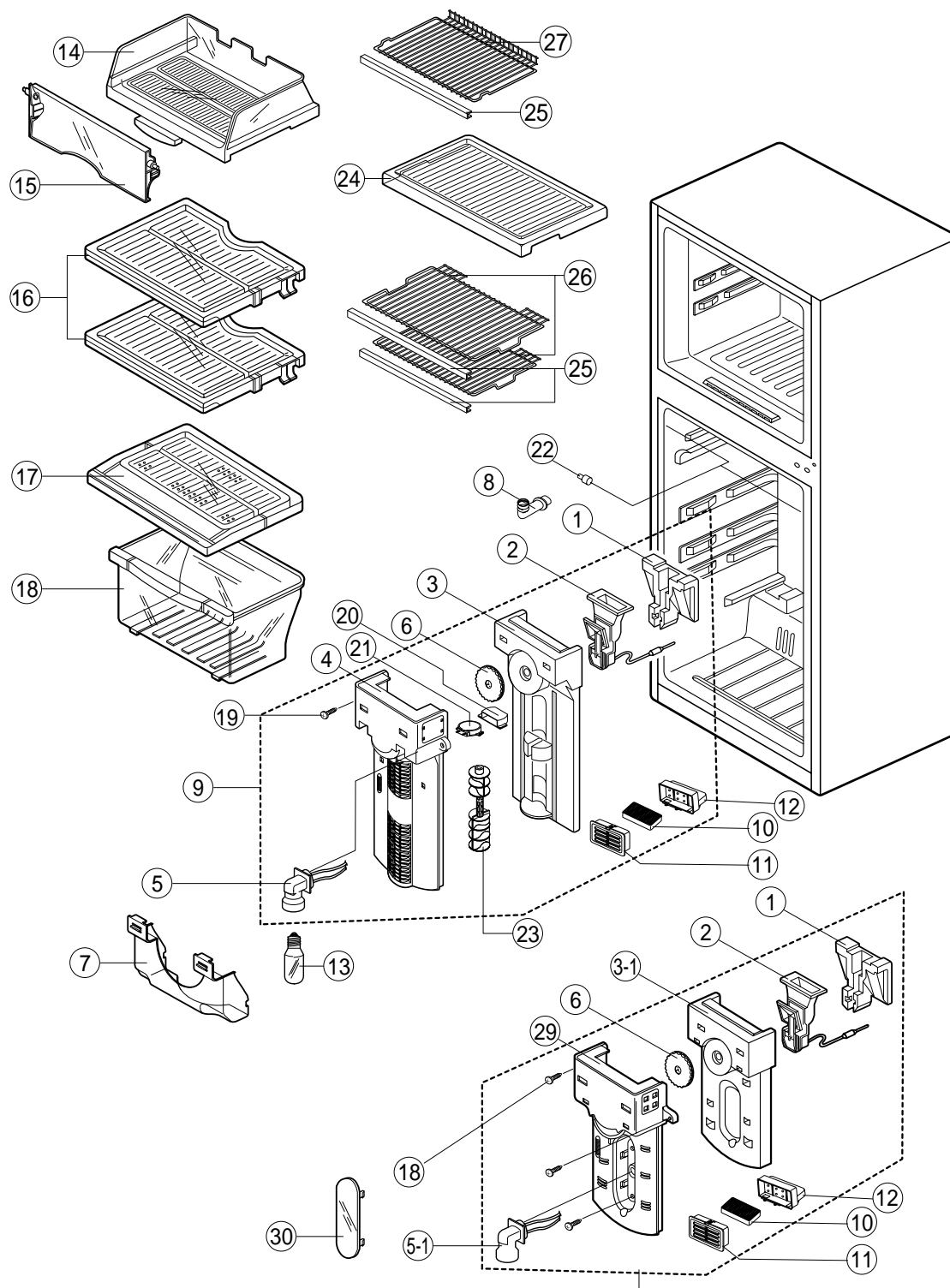

N°	Code	Désignation	Spécification	SR-32/33					SR-28/29				
				H	M	L	N	G	H	M	L	N	G
1	DA72-40193B	SPACER-DAMPER, B	FOAM-PS	1	1	1	1	1	1	1	1	1	1
2	DA67-10246B	ASSY-THERMO, DAMPER	705-E9C	1	1	1	1	1	1	1	1	1	1
3	DA72-40235A	SPACER-DAMPER, A	FOAM-PS	1	0	0	0	0	1	0	0	0	0
3-1	DA72-40194B	SPACER-DAPMER, A	FOAM-PS	0	1	1	1	1	0	1	1	1	1
4	DA63-30142A	COVER-MULTI, REF(X)	P.P	1	0	0	0	0	1	0	0	0	0
5	DA47-40112L	SOCKET-LAMP	250V 1A	1	0	0	0	0	1	0	0	0	0
5-1	DA47-40114D	SOCKET-LAMP(B)	250V 1A	0	1	1	1	1	0	1	1	1	1
6	DA64-10147	KNOB-DAMPER, THERMO.	ABS	1	1	1	1	1	1	1	1	1	1
7	DA63-10395B	COVER-LAMP, REF	MIPS	1	0	0	0	0	1	0	0	0	0
8	DA74-30135A	HOSE-DRAIN, CONNECT	SILICON	1	1	1	1	1	1	1	1	1	1
9	DA47-30151B	ASSY-DAMPER	SR-28/29 (220-240V), 32/33 (240V)	1	0	0	0	0	0	0	0	0	0
	DA47-30151C	ASSY-DAMPER	SR-28/29 (110~127 V)	1	0	0	0	0	0	0	0	0	0
	DA4730151D	ASSY-DAMPER	SR-32/33 (220 V)	0	0	0	0	0	1	0	0	0	0
	DA47-30151E	ASSY-DAMPER	SR-32/33 (110~127 V)	0	0	0	0	0	1	0	0	0	0
10	DA02-90108A	CATALYST-LTC	T5 W42 L42	1	1	0	0	0	0	0	0	0	0
11	DA63-10487A	CAP-PURIFIER	P.P	1	1	0	0	0	0	0	0	0	0
12	DA67-10443A	CASE-PURIFIER	P.P	1	1	0	0	0	1	1	0	0	0
13	4713-000188	ASSY-LAMP	220V~15W	2	1	1	1	1	2	1	1	1	1
	4713-001035	ASSY-LAMP	110V/30V/14W/16W	2	1	1	1	1	2	1	1	1	1
	DA63-000213	ASSY-LAMP	240V/15W	2	1	1	1	1	2	1	1	1	1
14	DA67-40137A	TRAY-CHILLED, ROOM	GPPS	1	1	0	0	1	1	1	0	0	1
15	DA63-10983B	COVER-CHILLED, ROOM	"	1	1	0	0	1	1	1	0	0	1
16	DA67-20164F	SHELF-REF (GOLD SP)	"	2	2	2	0	0	2	2	2	0	0
	DA67-20164F	SHELF-REF	"	2	2	2	1	0	2	2	2	0	0
17	DA63-10248C	COVER-VEGETABLE	"	1	1	1	1	1	1	1	1	1	1
18	DA67-10196A	TRAY-VEGETABLE	"	1	1	1	1	1	1	1	1	1	1
19	6002-000471	SCREW-TAP, TH	1-4 X 12 STS304	2	2	2	2	2	2	2	2	2	2
20	DA63-40134A	GROMMET-MOTOR	NBR	1	0	0	0	0	1	0	0	0	0
21	DA31-10107D	GEARED-MOTOR	M2LC18AR01(220~240V)	1	0	0	0	0	1	0	0	0	0
	DA31-10107E	"	M2BC18AR01(110~127V)	1	0	0	0	0	1	0	0	0	0
22	DA63-40131A	FIXER-CHILLED, ROOM	ABS	2	2	0	0	2	2	2	0	0	2
23	DA31-20108A	BLADE-DAMPER	ABS	1	0	0	0	0	1	0	0	0	0
24	DA67-20165R	SHELF-CHILLED	GPPS	0	0	1	0	0	0	0	1	0	0
25	DA64-20150N	TRIM-SHELF	RD-PVC	0	0	0	3	2	0	0	0	3	2
26	DA67-20022A	SHELF-REF (WIRE)	MSWR10	0	0	0	2	2	0	0	0	2	2
27	DA67-20023A	SHELF-CHILLED (WIRE)	"	0	0	0	1	0	0	0	0	1	0
28	DA47-30150D	ASSY-DAMPER (MULTI)	SR-28/29,DEODO.(É)	0	1	1	0	0	0	0	0	0	0
	DA47-30150F	ASSY-DAMPER "	SR-32/33,NON.DEODO.	0	0	0	1	1	0	0	0	0	0
	DA47-30150B	ASSY-DAMPER "	SR-28/29, DEODO.	0	0	0	0	0	0	1	1	0	0
	DA47-30150E	ASSY-DAMPER "	SR-32/33, NON.DEODO.	0	0	0	0	0	0	0	0	1	1
29	DA63-10249J	COVER-MULTI, REF(M)	P.P	0	1	1	1	1	0	1	1	1	1
30	DA63-10388A	COVER-LAMP, REF	MIPS	0	1	1	1	1	0	1	1	1	1

Les pièces en rapport avec la sécurité électrique apparaissent en gris.

11-2 Porte et liste des pièces

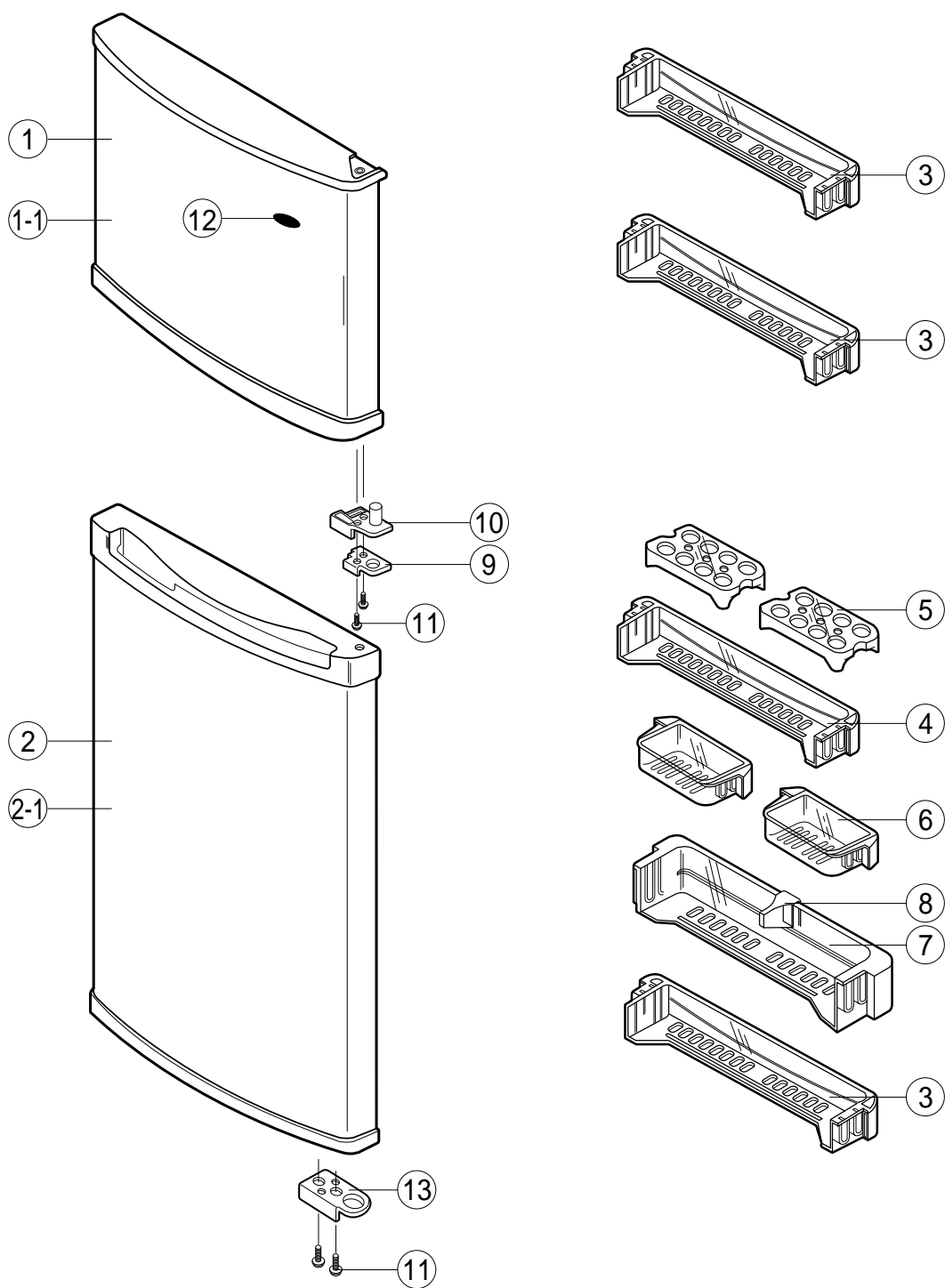

N°	Code	Désignation	Spécification	SR-32/33					SR-28/29				
				H	M	L	N	G	H	M	L	N	G
1	DA91-10316A	ASSY-FOAM DOOR, FRE	SR-32/33 OPTION	1	1	1	1	1	0	0	0	0	0
1-1	DA91-10316B	"	SR-28/29 OPTION	0	0	0	0	0	1	1	1	1	1
2	DA91-10318A	ASSY-FOAM DOOR, REF	SR-32/33 OPTION	1	1	1	1	1	0	0	0	0	0
2-1	DA91-10317B	"	SR-28/29 OPTION	0	0	0	0	0	1	1	1	1	1
3	DA63-20164B	GUARD-FRE(REF)	GPPS	3	3	3	3	3	3	3	3	3	3
4	DA63-20163B	GUARD-EGG	"	1	1	1	1	1	1	1	1	1	1
	DA67-20170A	GUARD-EGG	"	0	0	0	0	0	1	1	1	1	1
5	DA63-40178A	TRAY-EGG	"	1	1	1	1	1	0	0	0	0	0
6	DA63-20186C	GUARD-VARIETY	"	2	2	2	2	2	1	1	1	1	1
7	DA71-20165C	GUARD-BOTTLE	"	2	2	2	2	2	2	2	2	2	2
8	DA71-70128A	GUIDE-BOTTLE	P.P	1	1	1	1	1	1	1	1	1	1
9	DA71-40133A	STOPPER-DOOR(C)	SCP1 T2.0 ZPC3	1	1	1	1	1	1	1	1	1	1
10	DA71-40116A	STOPPER-DOOR(A)	POM	1	1	1	1	1	1	1	1	1	1
11	6001-000061	SCREW-MACHINE	TH M4X12 STS304	4	4	4	4	4	4	4	4	4	4
12		INLAY-MASCOT	PET	1	1	1	1	1	1	1	1	1	1
13	DA71-40125A	STOPPER-DOOR(B)	SCP1 T2.5 ZPC	1	1	1	1	1	1	1	1	1	1

Les pièces en rapport avec la sécurité électrique apparaissent en gris.

11-4 Vue éclatée de l'armoire et liste des pièces

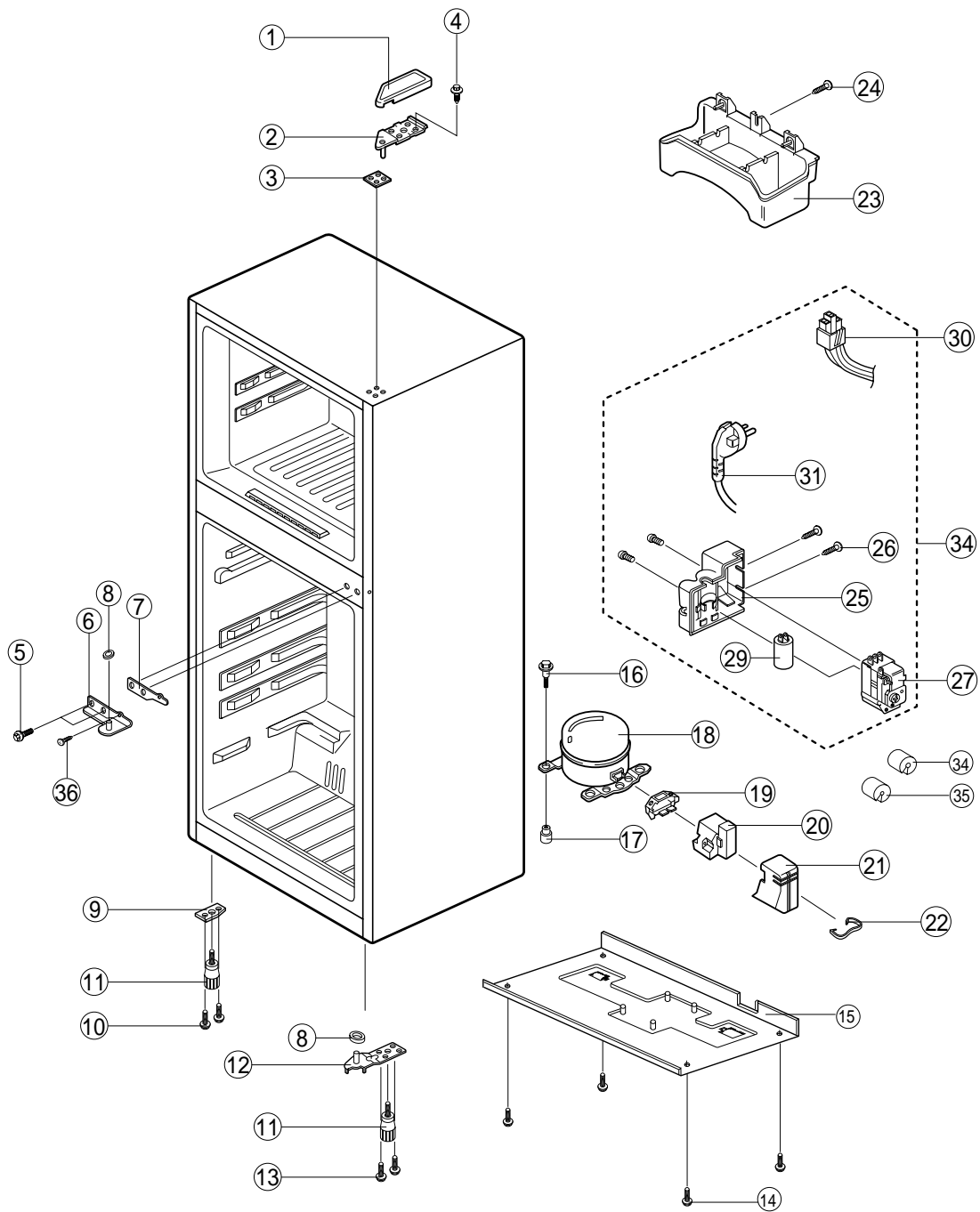

N°	Code	Désignation	Spécification	SR-32/33					SR-28/29				
				H	M	L	N	G	H	M	L	N	G
1	DA63-10969B	COVER-HINGE, UP	PP	1	1	1	1	1	1	1	1	1	1
2	DA61-10213A	HINGE, UP	SCP1 T2.5 ZPC3	1	1	1	1	1	1	1	1	1	1
3	DA63-50145A	SHIM-HINGE, UP	RD-PVC	1	1	1	1	1	1	1	1	1	1
4	DA60-10124A	SCREW-TAP, TITE	ZPC2-Y M6X16	4	4	4	4	4	4	4	4	4	4
5	DA61-10213C	SCREW-TAP, TITE	ZPC2-W M6X24	2	2	2	2	2	2	2	2	2	2
6	DA61-10220A	HINGE-MID	SCP1 T4 ZPC2	1	1	1	1	1	1	1	1	1	1
7	DA63-50159A	SHIM-HINGE, MID	RD-PVC T1.0	1	1	1	1	1	1	1	1	1	1
8	DA60-40102A	WASHER	ID8.5 0D16 T1 NY-66	1	1	1	1	1	1	1	1	1	1
9	DA61-70256A	SUPT-FOOT	SHP1 T4.5 ZPC3	2	2	2	2	2	2	2	2	2	2
10	DA60-10124A	SCREW-TAP, TITE	ZPC2-Y M6X16	3	3	3	3	3	3	3	3	3	3
11	DA61-30105A	FOOT-FRONT	PP	2	2	2	2	2	2	2	2	2	2
12	DA61-10150A	HINGE-LOW	SHP1 T4.5 ZPC3	1	1	1	1	1	1	1	1	1	1
13	6001-000034	SCREW-TH	STS M4X15	4	4	4	4	4	4	4	4	4	4
14	DA60-10124A	SCREW-TAP, TITE	ZPC2-Y M6X16	4	4	4	4	4	4	4	4	4	4
15	DA71-60196C	BASE-COMP, ASSY	SBHG1 T1.2	1	1	1	1	1	1	1	1	1	1
16	DA65-20101A	CLAMP-COMP	SK5	4	4	4	4	4	4	4	4	4	4
17	DA63-40004A	GROMMET-COMP	NBR	4	4	4	4	4	4	4	4	4	4
18	SD152P-L1W2	COMPRESSOR	127 V / 60 HZ	1	1	1	1	1	1	1	1	1	1
	SD162H-L1U2	COMPRESSOR	220 V / 50~60 HZ	1	1	1	1	1	1	1	1	1	1
	SD162Q-L1U2	COMPRESSOR	230~240 V / 50 HZ	1	1	1	1	1	1	1	1	1	1
	SD152C-L1W2	COMPRESSOR	100 V / 60 HZ	1	1	1	1	1	1	1	1	1	1
19	DA34-10003R	O/L-PROTECTOR (115/60)	4TM427PHBYY-53	1	1	1	1	1	1	1	1	1	1
	DA34-10003U	O/L-PROTECTOR (127/60)	4TM317RHYY-53	1	1	1	1	1	1	1	1	1	1
	DA34-10003A	O/L-PROTECTOR (220/50)	4TM265RHYY-53	1	1	1	1	1	1	1	1	1	1
	DA34-10003A	O/L-PROTECTOR (240/50)	4TM222PHBYY-53	1	1	1	1	1	1	1	1	1	1
20	DA35-10002C	PTC-RELAY	912X32E100MQ16APE3	1	1	1	1	1	1	1	1	1	1
	DA35-10002D	PTC-RELAY	912X35E330MT20APE2	1	1	1	1	1	1	1	1	1	1
21	DA63-10722A	COVER-RELAY	PP	1	1	1	1	1	1	1	1	1	1
22	DA65-10002A	CLAMP-RELAY, COVER	SK-5	1	1	1	1	1	1	1	1	1	1
23	DA67-40309A	TRAY-DRAIN, WATER	PP	1	1	1	1	1	1	1	1	1	1
24	6002-000213	SCREW-TAP, TH	1-4X12 FE, FZY	2	2	2	2	2	2	2	2	2	2
25	DA67-10430C	CASE-JUNCTION	PP	1	1	1	1	1	1	1	1	1	1
26	6002-000213	SCREW-TAP, TH	1-4X12 FE, FZY	1	1	1	1	1	1	1	1	1	1
27	DA45-10003F	TIMER-DEFROST	100V~127V 6H40M	1	1	1	1	1	1	1	1	1	1
	DA45-10003E	TIMER-DEFROST	220V~240V 6H40M	1	1	1	1	1	1	1	1	1	1

Les pièces en rapport avec la sécurité électrique apparaissent en gris.

N°	Code	Désignation	Spécification	SR-32/33					SR-28/29					
				H	M	L	N	G	H	M	L	N	G	
28	6002-000213	SCREW-TAP, TH	1-4X12 FE, FZY	2	2	2	2	2	2	2	2	2	2	2
29	2501-000413	C-OIL (RUN)	8 μ F/250VAC	1	1	1	1	1	1	1	1	1	1	1
	2501-000427	C-OIL (RUN)	3.5 μ F/350VAC	1	1	1	1	1	1	1	1	1	1	1
	2501-000422	C-OIL (START)	100 μ F/125VAC	1	1	1	1	1	1	1	1	1	1	1
30	DA39-20386C	WIRE-HARNESS RELAY	220V~240V	1	1	1	1	1	1	1	1	1	1	1
	DA39-20386D	WIRE-HARNESS RELAY	100V~127V	1	1	1	1	1	1	1	1	1	1	1
31		CBF	BUYER OPTION	1	1	1	1	1	1	1	1	1	1	1
32	DA34-10122C	SWITCH-DOOR	GRN 2B	1	1	1	1	1	1	1	1	1	1	1
33	DA63-40237G	GROMMET-DISCHARGE	NBR P16	1	1	1	1	1	1	1	1	1	1	1
34	DA63-40237H	GROMMET-DISCHARGE	NBR P14	1	1	1	1	1	1	1	1	1	1	1
35	DA60-41120B	CABLE-TIE	NY66	1	1	1	1	1	1	1	1	1	1	1
36	6002-000453	SCREW-TAPPING	FH M4X12 STS304	1	1	1	1	1	1	1	1	1	1	3
37	DA73-30103A	DYER	CU,OD15.88,L118	1	1	1	1	1	1	1	1	1	1	1

Les pièces en rapport avec la sécurité électrique apparaissent en gris.