

9. Exploded View

9-1. Freezer room

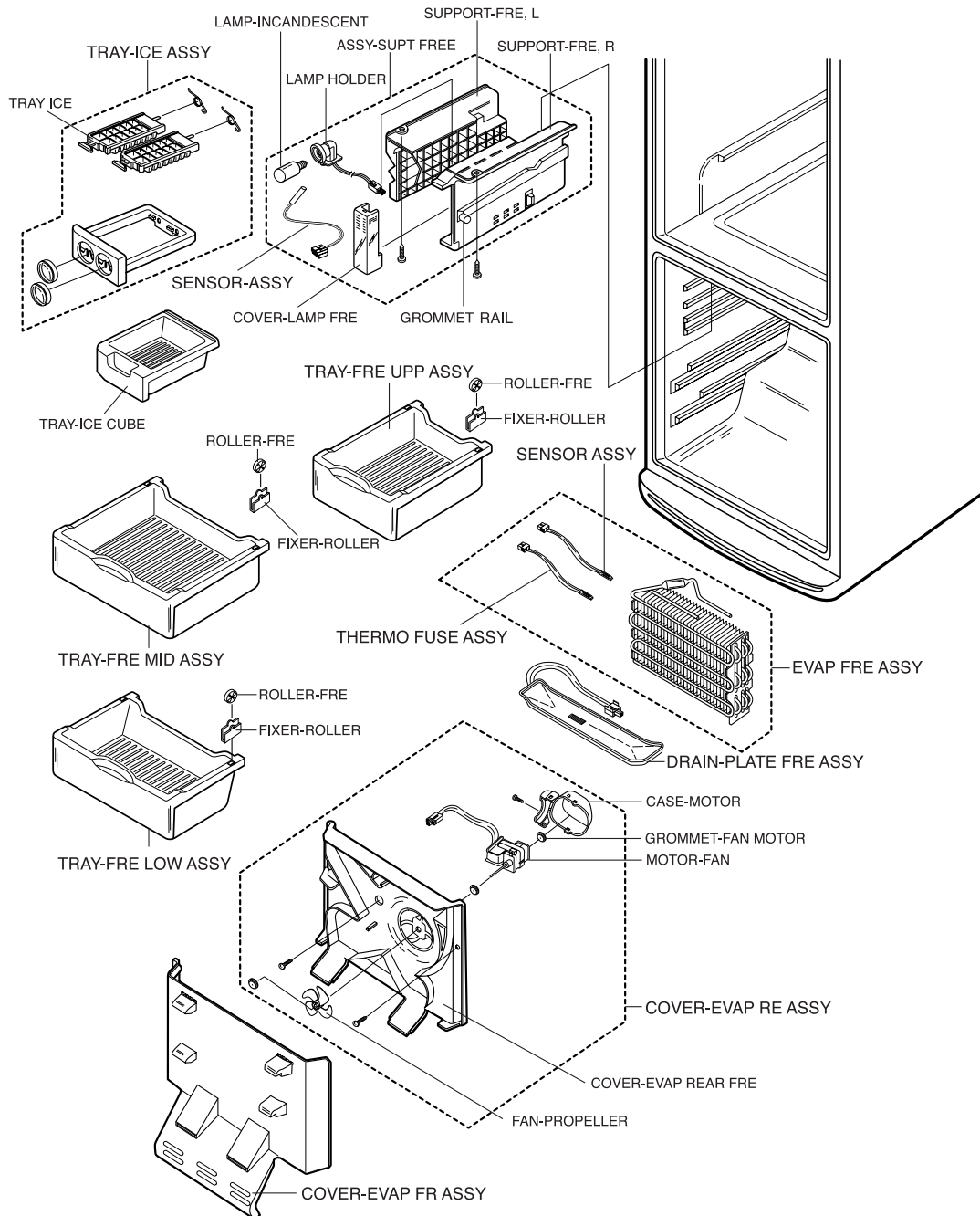

9-2. Refrigeration room

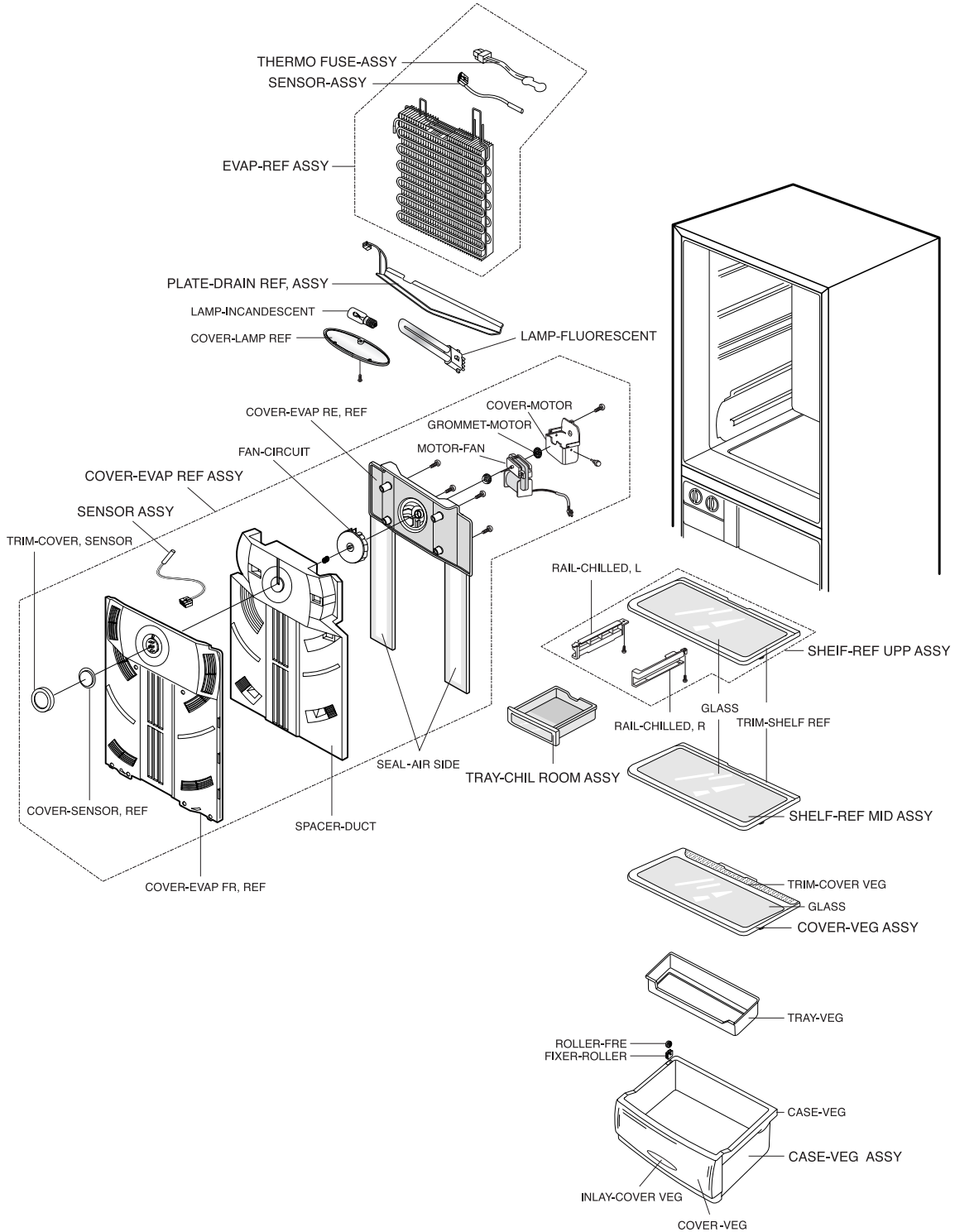

9-3. Door parts

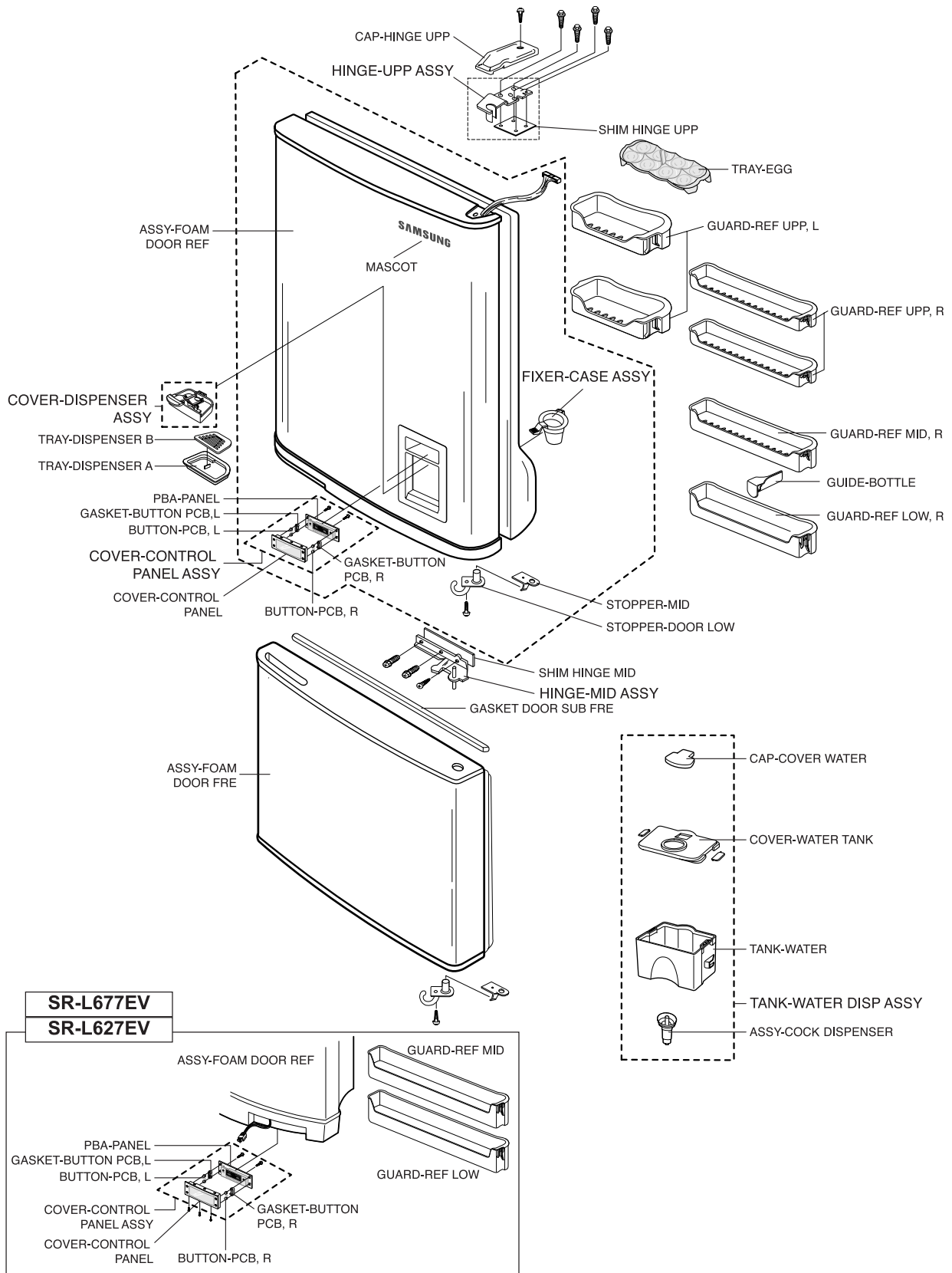

9-4. Cabinet parts & unit

