

Libro de instrucciones
51 6497
(E, GB, P, F, D)

- 1) 03 1989
- 2) 03 1987
- 3) 03 1988
- 4) 03 5731
- 5) 03 3055
- 6) 06 6770
- 7) 06 7467

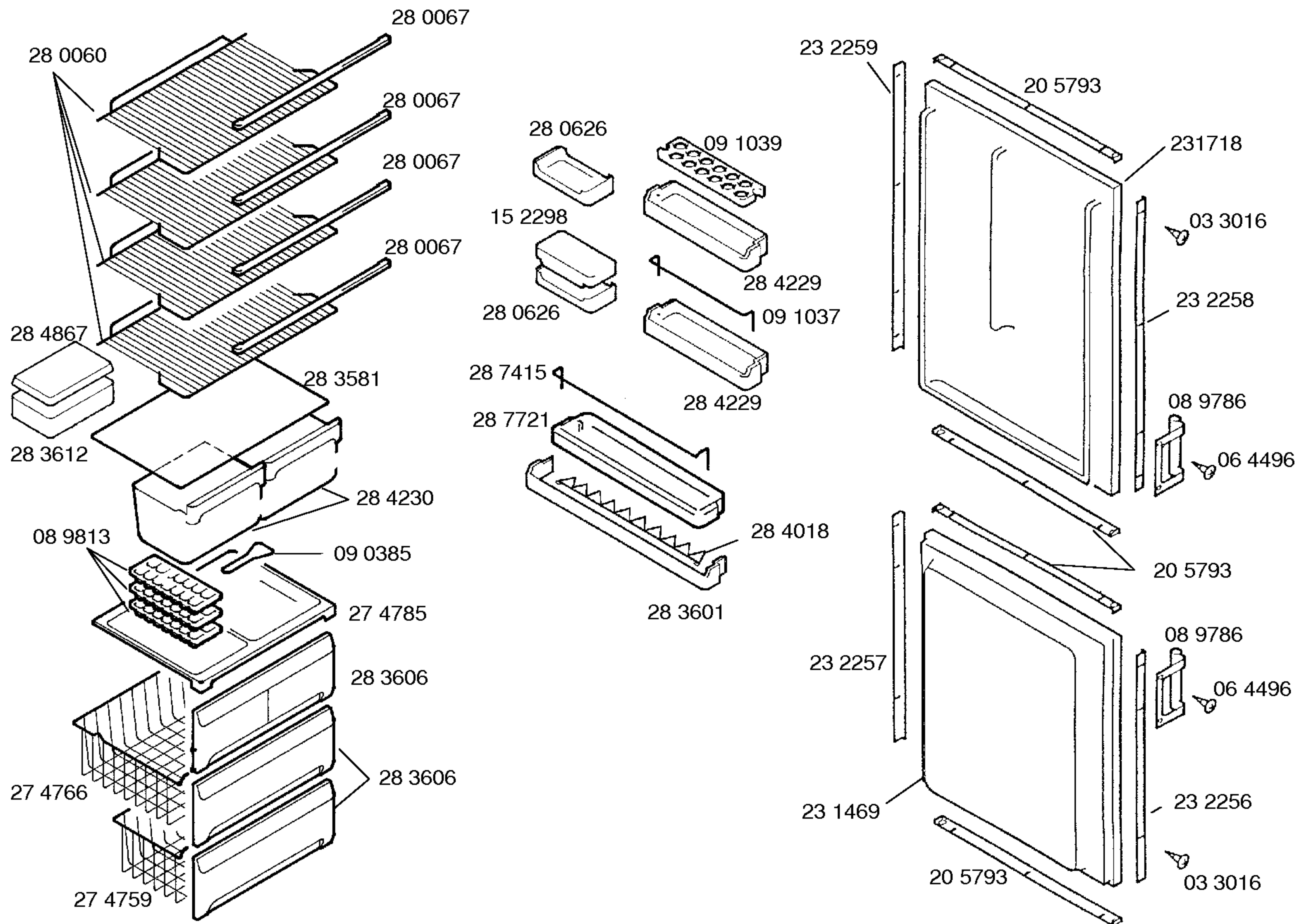

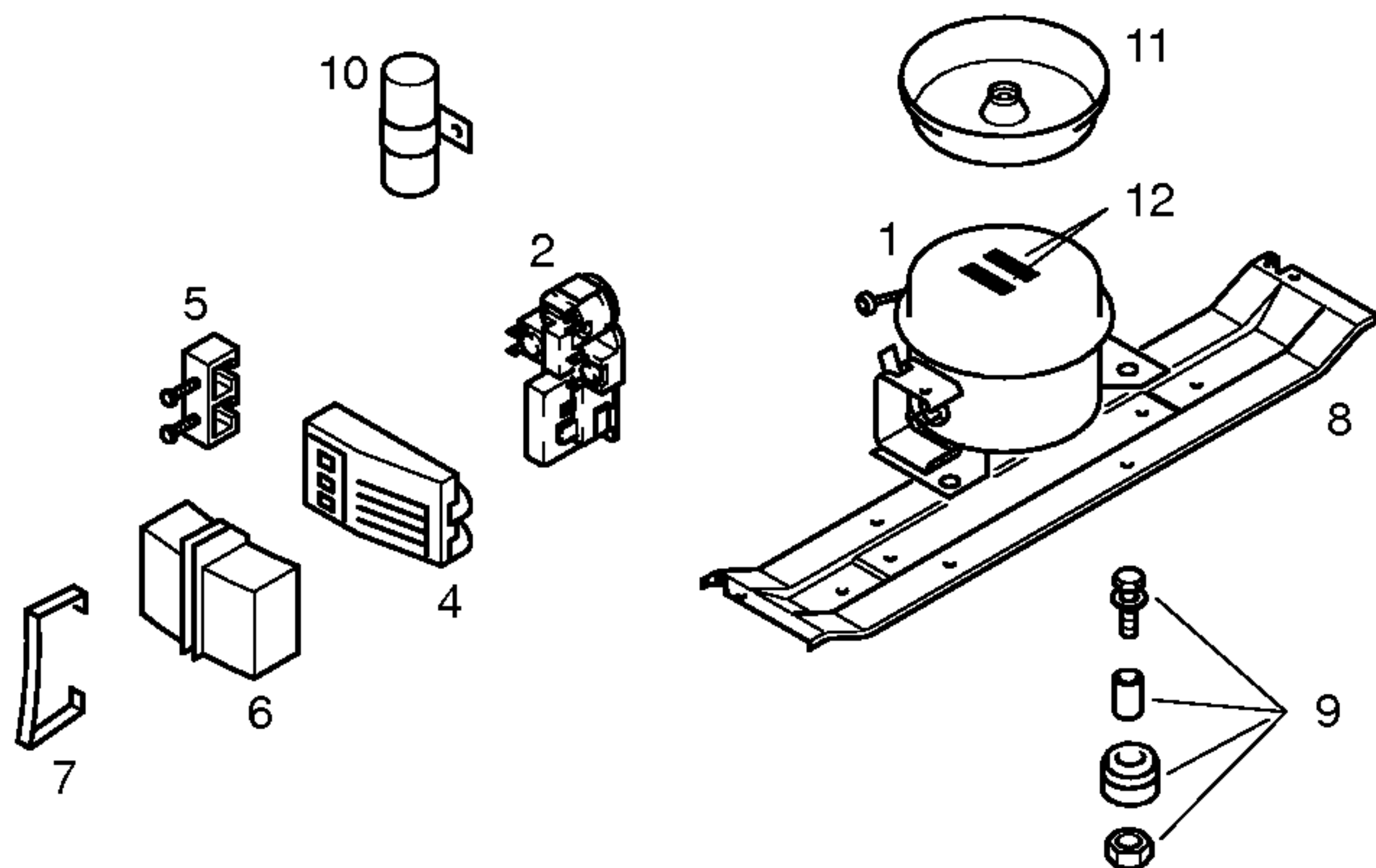

Pos.	MATSUSHITA	MATSUSHITA
	SB43C90WA	SB48C10WA
1	14 1598	14 1598
2	15 1824	
3		
4		
5		
6		
7		
8	28 0162	
9	05 0166	05 0166
10		
11	09 5320	
12		
13		

TECHNISCHE DATEN/TECHNICAL DATA/DONNEES TECHNIQUES/DATOS TECNICOS		
Verdichter/Compressor/Compresseur/Compresor Typ/Type/Tipo Förderleistung/Delivery/Debit/Aspiración l/h Anlaufstrom/Starting current/Cour.démarrage/Int.arranque A Widerstand/Resistance/Resistencia. Ha/main/prin. Ohm Hi/aux.	MATSUSH. SB43C90WA	MATSUSH. SB48C10WA
Temp.Reyler/Thermostat/Termostato Typ/Type/Tipo Reglerstellung/Position/Conexión Schaltwerte/Switching values/ ..ein/conex.°C Valeurs de commutation/Descon. ..aus"/descon. (..abtaven' od) ..alarm'	DANFOS 077B62 MIN.-MAX +6° -13° -28°	RANCO K54 L1924 MIN.-MAX -14° -24° -21° -31° -15
Füllmenge/Fill. quantity/Charge/Carga R12	g	80
Anschlußwert/Comm. load/puiss. Connect./Potenc.	W	94
Heizung/Heater/Chauflage/Resistenc.descong. Widerstand/Resistance/Resistencia Leistung/Power/Puissance/Potencia	Ohm W	
Ventilador/Blower/Ventilateur/Ventilador Widerstand/Resistance/Resistencia	Ohm	
Magnetventil/Magnetic valve/Electrovanne/Electrovalvula Widerstand/Resistance/Resistencia Spannung/Volare/Tension/Tensión	Ohm V	
Temp.Reyler/Thermostat/Termostato ambiente para ventilador refrigerador		